



# INSTALLATION INSTRUCTIONS

## PART NUMBER: RK-3931

This Assembly Fits:

SEE CATALOG FOR CURRENT APPLICATIONS

Congratulations, you have purchased the finest custom air cleaner that money can buy. With proper care, this filter will last 1 million miles or more. This custom air cleaner replaces the stock air cleaner assembly. The following procedure must be followed to ensure a proper fit and seal of the custom air cleaner.

### TOOLS:

7/16" socket  
 3/16" allen wrench  
 5/16" allen wrench  
 5/32" allen wrench  
 extension  
 ratchet

### PARTS LIST:

Description	Qty	Part #
A 1/4-20 Button Head	5	07706
B Cushion Plate	1	82918
C Air Filter	1	E-3975
D Spacer	2	06500
E 1/4-20 Socket Head	3	07731
F Velocity Stack	1	08936
G Back plate	1	01906
H O-ring	2	07761
I Bracket	1	070066
J Thread Locker	1	482

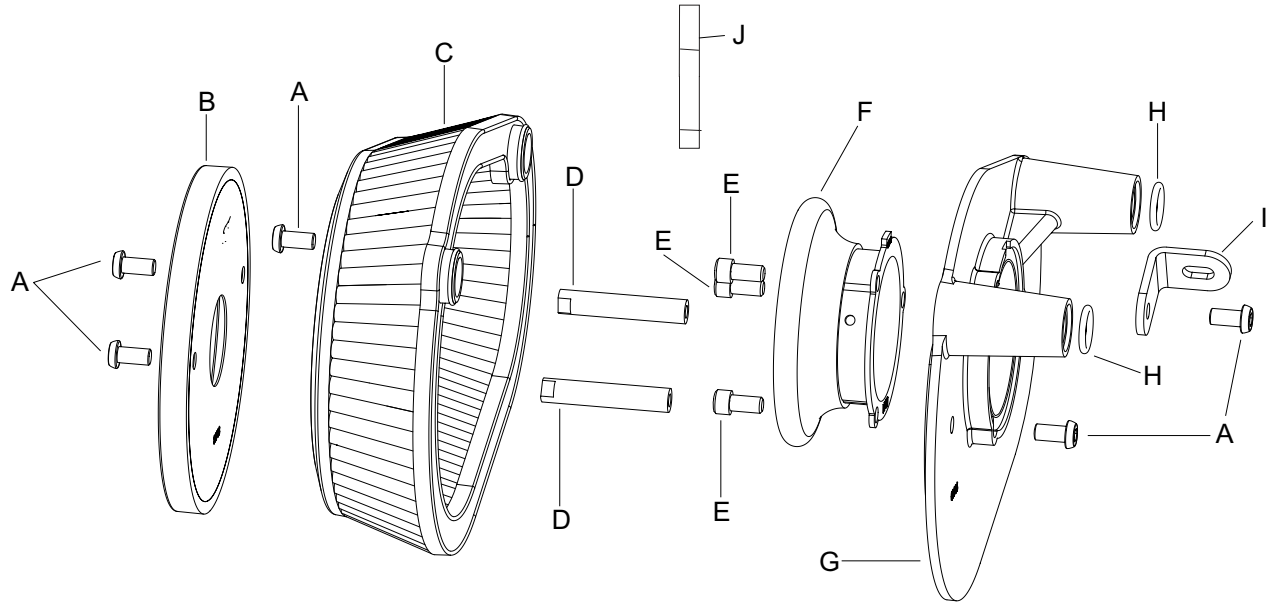

**NOTE: FAILURE TO FOLLOW INSTALLATION INSTRUCTIONS AND NOT USING THE PROVIDED HARDWARE MAY DAMAGE THE THROTTLE BODY AND ENGINE.**

### TO START:

1. Turn off the ignition and disconnect the negative battery cable.



2. Remove the air filter cover mounting bolt and then remove the cover from the vehicle.



3. Remove the three air filter mounting bolts, unhook the two breather tubes from the breathers and then remove the air filter from the vehicle as shown. **NOTE: It will be necessary to remove the clip nut to access the lower mounting bolt.**

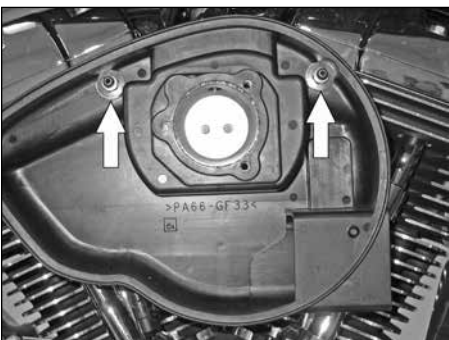

4. Remove the two breather bolts shown.



5. Remove the stock air filter base and gasket from the vehicle.  
**NOTE: Some models are equipped an intake valve solenoid connector on the back of the stock filter base. Unhook the connector from the back plate.**



6. Install the provided venturi into the K&N® back plate as shown.  
**NOTE: The velocity stack is keyed and will only fit one way into the back plate.**



7. Install the three backing plate mounting bolts through the velocity stack.

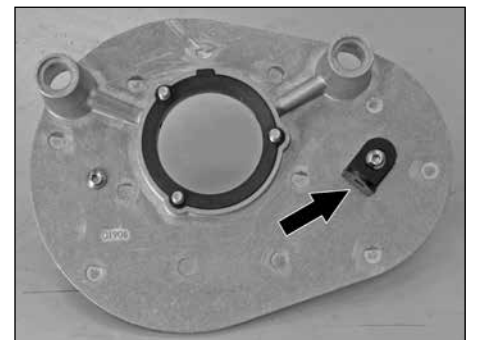

8. Install the two stand-offs onto the backing plate using the two provided bolts (07706). On models equipped with an intake valve solenoid pigtail, be sure to install the provided bracket with the bottom stand-off bolt.

**NOTE: Must apply the supplied thread locker to the threads of the supplied stand-off bolts.**

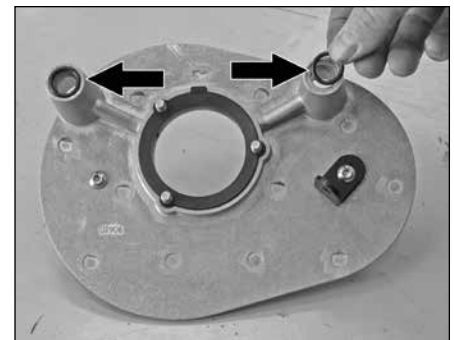

9. Install the two provided o-rings into the backing plate as shown.

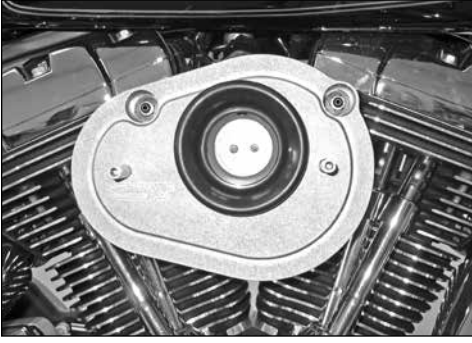

10. Install the backing plate onto the throttle body and secure with the bolts installed during step #7. Then secure the backing plate to the engine with the factory breather bolts.

**NOTE: On models equipped with the intake valve solenoid, attach the pigtail to the bracket installed during step #9. A bypass module will need to be installed (sold separately) on the connector to eliminate the "Engine Management Light" from turning on (non us models).**



11. Install the cover stand-off onto the K&N® air filter as shown using the provided bolt.

**NOTE: Be sure to apply Loctite to the bolt.**

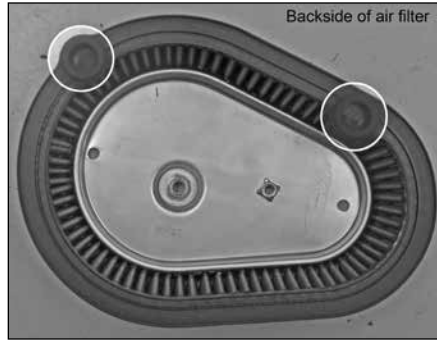

12. Make note of the breather ports on the backside of the air filter.



12a. Install the filter assembly onto the back plate as shown using the bolts provided. Be sure to apply Loctite onto the mounting bolts.

**NOTE: Make sure to apply pressure to the K&N® air filter to ensure it is completely seated against the backing plate before tightening the bolts.**

**NOTE: Check to make sure the breather ports of the filter are fully sealed.**



13. Remove the rubber gasket from the factory cover and then secure the cover to the filter assembly as shown.

**NOTE: Be sure not to over tighten the cover bolt as it will distort the cover.**

14. It will be necessary for all K&N® custom air cleaners to be checked periodically for realignment, clearance and tightening of all connections. Failure to follow the above instructions or proper maintenance may void warranty.

#### ROAD TESTING:

1. Start the engine with the transmission in neutral. Listen for air leaks or odd noises. For air leaks secure hoses and connections. For odd noises, find cause and repair before proceeding. This kit will function identically to the factory system except for being louder and much more responsive.

2. Test ride the vehicle. Listen for odd noises or rattles and fix as necessary.

3. If road test is fine, you can now enjoy the added power and performance from your kit.

4. K&N Engineering, Inc., suggests checking the air filter element periodically for excessive dirt build-up. When the element becomes covered in dirt (or once a year), service it according to the instructions on the Recharger® service kit, part number 99-5050 or 99-5000.