



INTAKE SYSTEMS FOR VEHICLES LISTED ARE 50 STATE LEGAL. SEE KNFILTERS.COM FOR CARB STATUS ON EACH PART FOR A SPECIFIC VEHICLE.

# INSTALLATION INSTRUCTIONS

**77-1570KS**  
**JEEP**  
**2014-16 Cherokee**  
**L4-2.4L**

**TOOLS NEEDED:**

- flat blade screw driver
- ratchet
- extension
- 8mm socket
- 10mm socket
- 13mm socket
- 10mm wrench
- 4mm allen
- 3mm allen
- t20 torx

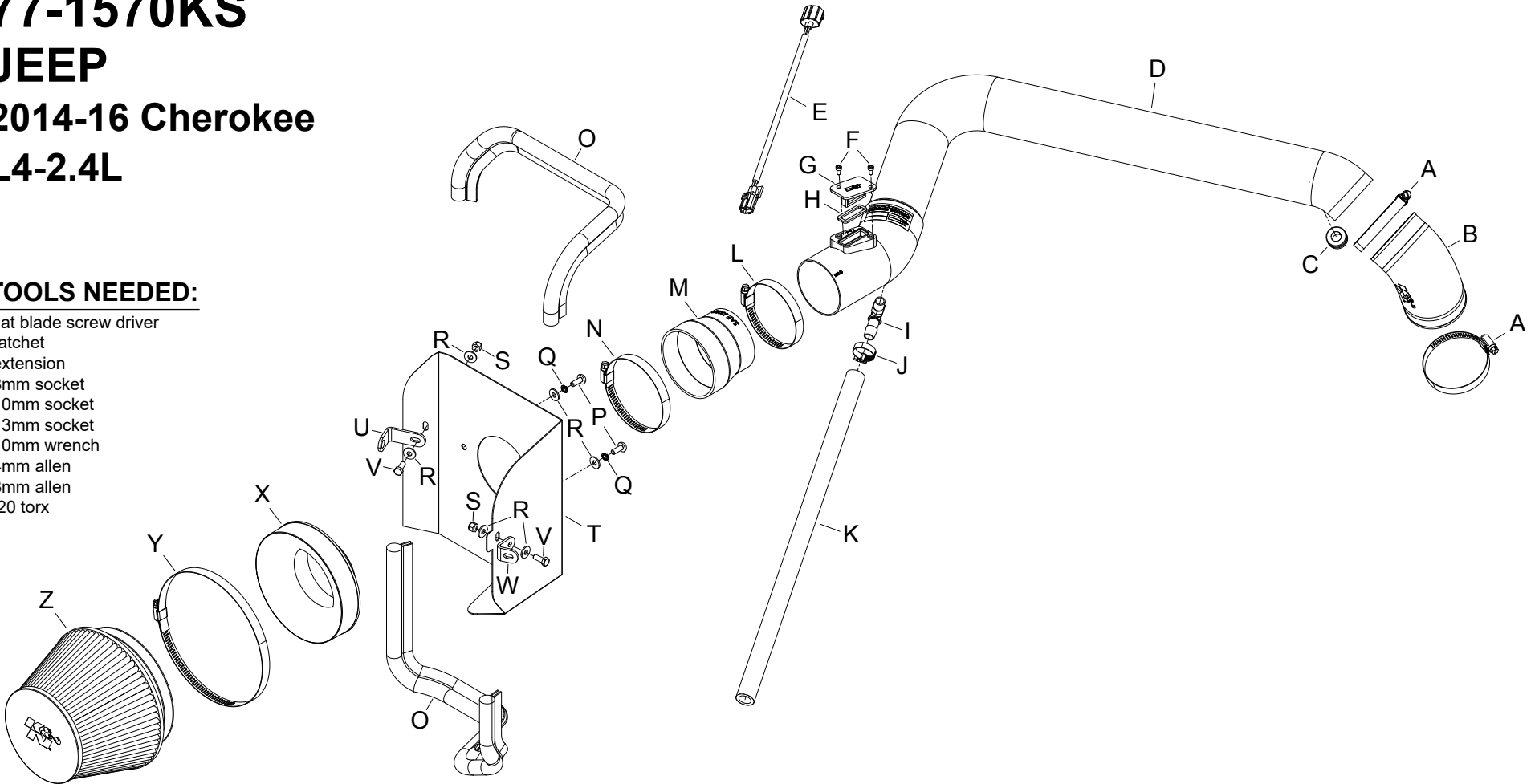

**PARTS LIST:**

Description	Qty.	Part #	Description	Qty.	Part #	Description	Qty.	Part #
A hose clamp #44 stainless	2	08560	J hose clamp #10 mini	1	08411	S nut; 6mm nylock, hexhead, ss	2	07512
B hose; 2.75" id angled 30deg	1	08489	K hose; 5/8" id x 20" l	1	08542	T heat shield	1	073175
C grommet; 1" od, 1/2" id, 1/2" thk	1	08064	L hose clamp #48	1	08601	U bracket; 63-1015, "l", fin, tb/pc	1	070712
D intake tube	1	27635	M hose; 3-1/2" to 3" id x 3" l tprd	1	084055	V bolt; 6mm-1.00 x 16mm, ss	2	07812
E extension harness; dodge iat	1	21680	N hose clamp #56	1	08620	W bracket; l, 63-1569, stl, tb/pc	1	064323
F bolt; m4 - 0.07 8mm, a/h cap, ss	2	07733	O edge trim (44")	1	102486	X adapter; universal, 6" filter 3.5"	1	21512-1
G block off plate; mass air sensor	1	21508	P bolt; m6 x 1.00 x 16mm, ss	2	07730	Y hose clamp #104	1	08697
H gasket; mass air sensor, 57-9027	1	09076	Q washer, m6 split lock zinc	2	1-3025	Z air filter	1	RC-2960
I vent; 90deg, 1/2" hose, 1/4" npt	1	08110FK	R washer; 6mm flat, ss	6	08269			

If you need any assistance please call 1-800-858-3333 to speak with a representative in our Customer Service Center before returning the product.

**NOTE: FAILURE TO FOLLOW INSTALLATION INSTRUCTIONS AND NOT USING THE PROVIDED HARDWARE MAY DAMAGE THE INTAKE TUBE, THROTTLE BODY AND ENGINE.**

**TO START:**

1. Turn off the ignition and disconnect the negative battery cable.  
**NOTE: Disconnecting the negative battery cable erases pre-programmed electronic memories. Write down all memory settings before disconnecting the negative battery cable. Some radios will require an anti-theft code to be entered after the battery is reconnected. The anti-theft code is typically supplied with your owner's manual. In the event your vehicles anti-theft code cannot be recovered, contact an authorized dealership to obtain your vehicles anti-theft code.**



2. Lift up and remove the decorative engine cover and remove it from the vehicle.



3. Disconnect the inlet air temperature sensor electrical connection.



4. On vehicles equipped with a humidity sensor, disconnect the humidity sensor electrical connection.



5. Disconnect the crank case vent hose from the valve cover port.



6. Remove the bolt securing the intake tube to the valve cover.



7. Loosen the hose clamp securing the intake tube to the air filter housing.



8. Loosen the hose clamp securing the intake tube to the throttle body and then remove the intake tube from the vehicle.



9. Remove the three bolts that secure the fresh air intake scoop and then lift up and remove the scoop from the vehicle.



10. Lift up the air filter housing to dislodge it from the mounting grommets and remove it from the vehicle.

**NOTE: K&N Engineering, Inc., recommends that customers do not discard factory air intake.**



11. Remove the bolt shown from the core support.  
**NOTE: This bolt will be reused in the next step.**



12. Install the provided heat shield mounting bracket (064323) onto the core support and secure with the factory bolt removed in the previous step.



13. Remove the inner fender bolt shown.  
**NOTE: This bolt will be reused in the next step.**



14. Install the heat shield mounting bracket (070712) onto the inner fender and secure with the factory bolt from the previous step.



15. Install the provided filter adapter into the heat shield and secure with the provided hardware.

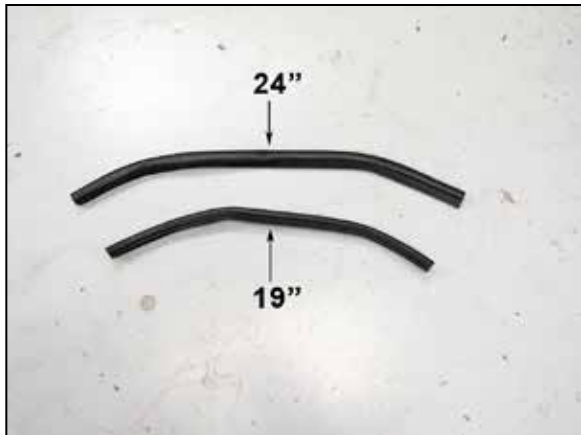

16. Cut the provided edge trim into two lengths as sections. One section will be 19" long, the other section will be 24" long.



17. Install the edge trim onto the heat shield as shown.



18. Install the heat shield assembly onto the brackets installed previously using the provided hardware.



19. If the vehicle is equipped with a humidity sensor, remove the humidity sensor from the factory air filter housing.



20. On vehicle equipped with a humidity sensor, install the sensor into the K&N® intake tube. On all other vehicles install the provided gasket onto the block off plate and install the block off plate onto the K&N® intake tube.



21. Install the provided grommet into the K&N® intake tube.



22. Remove the inlet air temperature sensor from the factory intake tube.



23. Remove the O-Ring from the inlet air temperature sensor and then install the sensor into the grommet installed into the K&N® intake tube.



24. Connect the provided inlet air temperature extension harness into the sensor as shown.



25. Install the 90° npt fitting into the K&N® intake tube as shown.

**NOTE: Plastic NPT fittings are easy to cross thread. Install the vent fitting "hand" tight, then turn it two complete turns with a wrench.**



26. Install the provided crank case breather hose onto the fitting and secure with the provided hose clamp.



27. Install the provided coupling hose (08489) onto the throttle body and secure with the provided hose clamp.



28. Install the provided coupling hose (084055) onto the filter adapter and secure with the provided hose clamp.



29. Install the K&N® intake tube into the coupling hose at the throttle body and then into the hose at the filter adapter. Adjust the tube for best fit and then secure with the provided hose clamps.



30. Connect the inlet air temperature sensor extension harness into the factory harness.



31. Connect the humidity sensor electrical connection.



32. Connect the crank case breather hose to the valve cover port.



33. Install the K&N® air filter and secure with the provided hose clamp.



34. Reinstall the decorative engine cover.



35. Reconnect the vehicle's negative battery cable. Double check to make sure everything is tight and properly positioned before starting the vehicle.

36. The C.A.R.B. exemption sticker, (attached), must be visible under the hood so that an emissions inspector can see it when the vehicle is required to be tested for emissions. California requires testing every two years, other states may vary.

37. It will be necessary for all K&N® high flow intake systems to be checked periodically for realignment, clearance and tightening of all connections. Failure to follow the above instructions or proper maintenance may void warranty.

#### ROAD TESTING:

1. Start the engine with the transmission in neutral or park, and the parking brake engaged. Listen for air leaks or odd noises. For air leaks secure hoses and connections. For odd noises, find cause and repair before proceeding. This kit will function identically to the factory system except for being louder and much more responsive.

2. Test drive the vehicle. Listen for odd noises or rattles and fix as necessary.

3. If road test is fine, you can now enjoy the added power and performance from your kit.

4. K&N Engineering, Inc., requires cleaning the intake system's air filter element every 100,000 miles. When used in dusty or off-road environments, our filters will require cleaning more often. We recommend that you visually inspect your filter once every 25,000 miles to determine if the screen is still visible. When the screen is no longer visible some place on the filter element, it is time to clean it. To clean and re-oil, purchase our filter Recharger® service kit, part number 99-5050 or 99-5000 and follow the easy instructions.

**INTAKE SYSTEMS FOR VEHICLES LISTED ARE 50 STATE LEGAL. SEE KNFILTERS.COM FOR CARB STATUS ON EACH PART FOR A SPECIFIC VEHICLE.**

\* FREE K&N® decal To register your warranty, please see us online at [knfilters.com/register](http://knfilters.com/register). FREE K&N® decal \*