



TYPHOON INTAKE SYSTEMS

NOT LEGAL FOR SALE OR USE ON ANY POLLUTION CONTROLLED MOTOR VEHICLE IN CALIFORNIA OR STATES ADOPTING CALIFORNIA EMISSION PROCEDURES.
See knfilters.com for CARB status on each part for a specific vehicle

INSTALLATION INSTRUCTIONS

69-9508T
AUDI
2014-15 A4 / A5 / A6
L4-2.0L

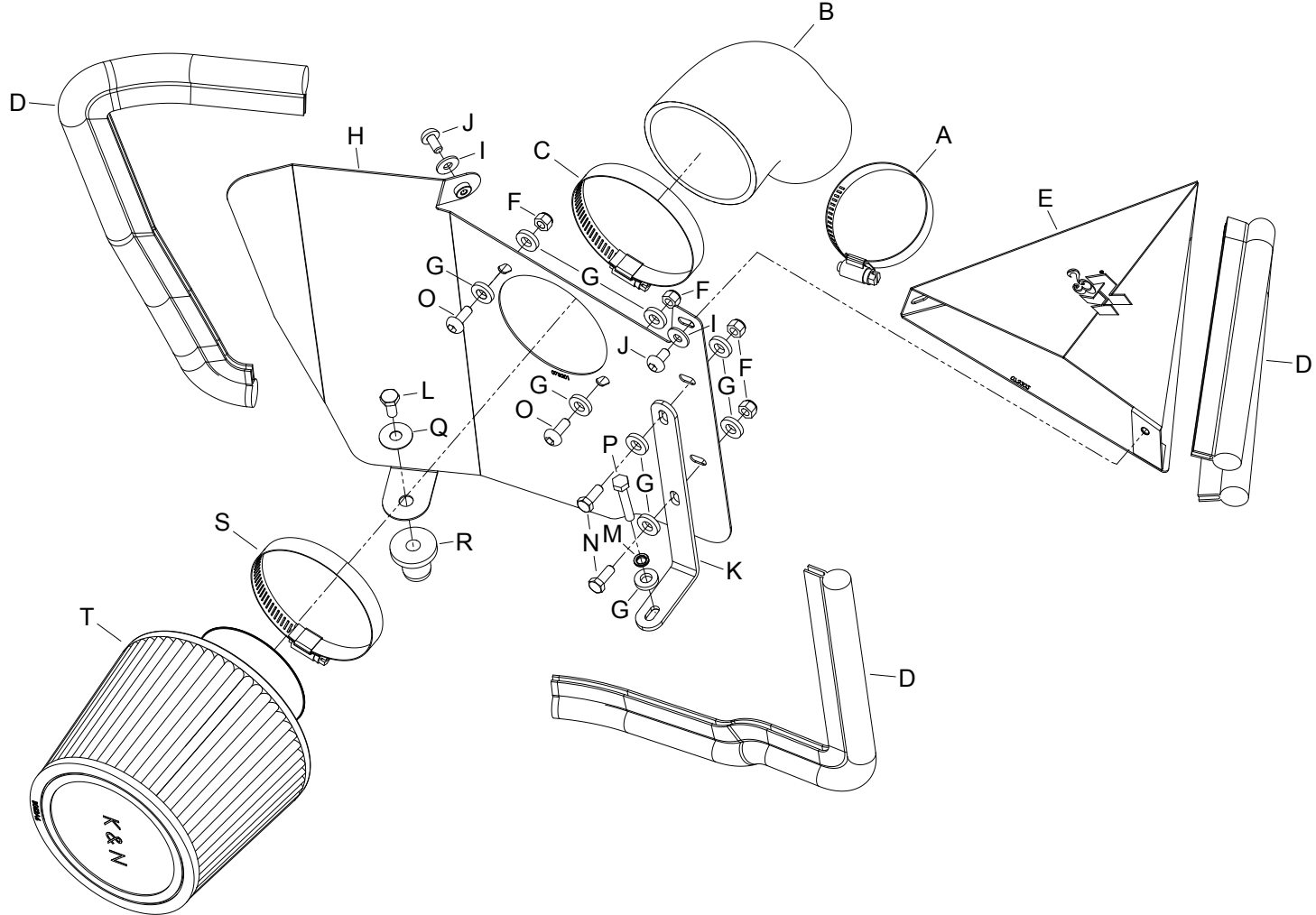

TOOLS NEEDED:

- flat blade screw driver
- ratchet
- 10mm socket
- 9/16" socket extension
- 4mm allen key
- t25 torx
- t27 torx
- 10mm wrench

PARTS LIST:

Description	Qty.	Part #	Description	Qty.	Part #	Description	Qty.	Part #
A hose clamp #36	1	08530	H heat shield	1	073201	O bolt; m6 x 1.00 x 16mm, ss	2	07730
B hose; 2.375" id x 3.125" id, angled	1	08490	I washer; 6mm flat, ss	2	08269	P bolt; hex m6-1 x 35mm	1	1-2002
C hose clamp #52	1	08610	J bolt; m6 x 1.00" 12mm, ss	2	07794	Q washer; 3/8" flat washer, ss	1	08134
D 55" edge trim	1	102480	K bracket; "I" 69-9505, stl, tb/pc	1	083139	R insert; 3/8-16 x 3/400 x 15/16I	1	08163
E fresh air duct	1	073202	L bolt; 3/8"-16 x 1-1/4" ss hex head	1	07779	S hose clamp # 48	1	08601
F nut; 6mm nylock, hexhead	4	07553	M washer, m6 split lock zinc	1	1-3025	T air filter	1	RU-3570
G washer; 1/4" id x 5/8" od	9	08275	N bolt; 6mm-1.00 x 16mm, ss	2	07812			

NOTE: FAILURE TO FOLLOW INSTALLATION INSTRUCTIONS AND NOT USING THE PROVIDED HARDWARE MAY DAMAGE THE INTAKE TUBE, THROTTLE BODY AND ENGINE.

TO START:

1. Turn off the ignition and disconnect the negative battery cable.
NOTE: Disconnecting the negative battery cable erases pre-programmed electronic memories. Write down all memory settings before disconnecting the negative battery cable. Some radios will require an anti-theft code to be entered after the battery is reconnected. The anti-theft code is typically supplied with your owner's manual. In the event your vehicles anti-theft code cannot be recovered, contact an authorized dealership to obtain your vehicles anti-theft code.



2. Disconnect the mass air sensor electrical connection.



3. Remove the fresh air intake duct from the vehicle.



4. Loosen the hose clamps securing the factory intake tube and then remove the intake tube from the vehicle.



5. Lift up the complete air filter housing to dislodge it from the mounting studs and then remove it from the vehicle.

NOTE: K&N Engineering, Inc., recommends that customers do not discard factory air intake.



6. Install the provided turbo inlet hose (08490) onto the turbo and secure with the provided hose clamp. **NOTE: Do not completely tighten at this time.**



7. Remove the two screws securing the mass air sensor into the air filter housing and then remove the mass air sensor assembly from the air filter housing.



8. Install the mass air sensor assembly onto the heat shield as shown using the provided hardware.

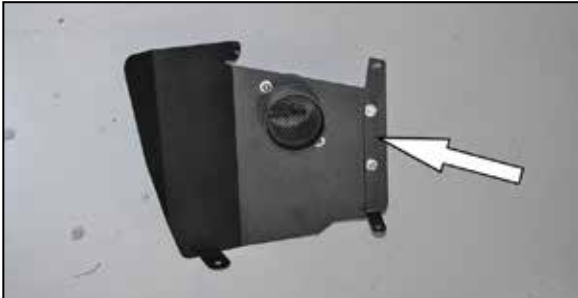

9. Install the provided heat shield mounting bracket (083139) onto the heat shield as shown using the provided hardware.



10. Cut the provided edge trim into three sections of 18", 17" and 16".



11. Install the 18" section onto the fresh air intake duct as shown.



12. Install the 16" and 17" section onto the heat shield as shown.



13. Install the insert nut onto the heat shield with the mounting bolt as shown.



14. Remove the headlight mounting bolt shown.



15. Install the heat shield assembly into the vehicle so that the insert nut enters the air filter housing mounting location and the mounting tab aligns with the headlight mounting location. Install the turbo inlet hose onto the mass air sensor and then secure the hose clamps and mounting hardware.



16. Install the K&N® air filter onto the mass air sensor and secure with the provided hose clamp.



17. Reconnect the mass air sensor electrical connection.



18. Install the K&N® fresh air intake duct and secure with the provided hardware.



19. Reconnect the vehicle's negative battery cable. Double check to make sure everything is tight and properly positioned before starting the vehicle.

20. It will be necessary for all K&N® high flow intake systems to be checked periodically for realignment, clearance and tightening of all connections. Failure to follow the above instructions or proper maintenance may void warranty.

ROAD TESTING:

1. Start the engine with the transmission in neutral or park, and the parking brake engaged. Listen for air leaks or odd noises. For air leaks secure hoses and connections. For odd noises, find cause and repair before proceeding. This kit will function identically to the factory system except for being louder and much more responsive.

2. Test drive the vehicle. Listen for odd noises or rattles and fix as necessary.

3. If road test is fine, you can now enjoy the added power and performance from your kit.

4. K&N Engineering, Inc., requires cleaning the intake system's air filter element every 100,000 miles. When used in dusty or off-road environments, our filters will require cleaning more often. We recommend that you visually inspect your filter once every 25,000 miles to determine if the screen is still visible. When the screen is no longer visible some place on the filter element, it is time to clean it. To clean and re-oil, purchase our filter Recharger® service kit, part number 99-5050 or 99-5000 and follow the easy instructions.

NOT LEGAL FOR SALE OR USE ON ANY POLLUTION CONTROLLED MOTOR VEHICLE IN CALIFORNIA OR STATES ADOPTING CALIFORNIA EMISSION PROCEDURES.

See knfilters.com for CARB status on each part for a specific vehicle