

INSTALLATION INSTRUCTIONS

69-8615TS
SCION
2008-12 xD
L4-1.8L

PARTS LIST:

Description	Qty.	Part #
A Hose Clamp #44	2	08560
B Hose; 2-5/8"ID To 2-3/4"ID TPRD	2	084014
C Hose Clamp #40	2	08554
D Intake Tube	1	27410
E Bracket; Twist "L", STL FB/PC	1	06721
F Bolt; 6MM-1.00 X 16MM, SS	1	07812
G Washer; 1/4" Lock, ZN	1	08198
H Washer; 1/4"ID X 5/8"OD - SAE	5	08275
I Hose; 5/8"ID X 14"L, Black Silicone	1	084083
J Bracket; Twist, STL	1	06720
K Bolt; M6 X 1.00" X 20MM Hexhead	1	07795
L Spacer; .625" OD X .250"ID X .250"L	2	06555
M Nut; 6MM Nylock, Hexhead, SS	2	07512
N Bolt; M6-1.00 X 25MM Buttonhead	1	07729
O Heat Shield	1	07629
P Edge Trim	1	102499
Q Hose Clamp #60	1	08624
R Air Filter	1	RC-4630

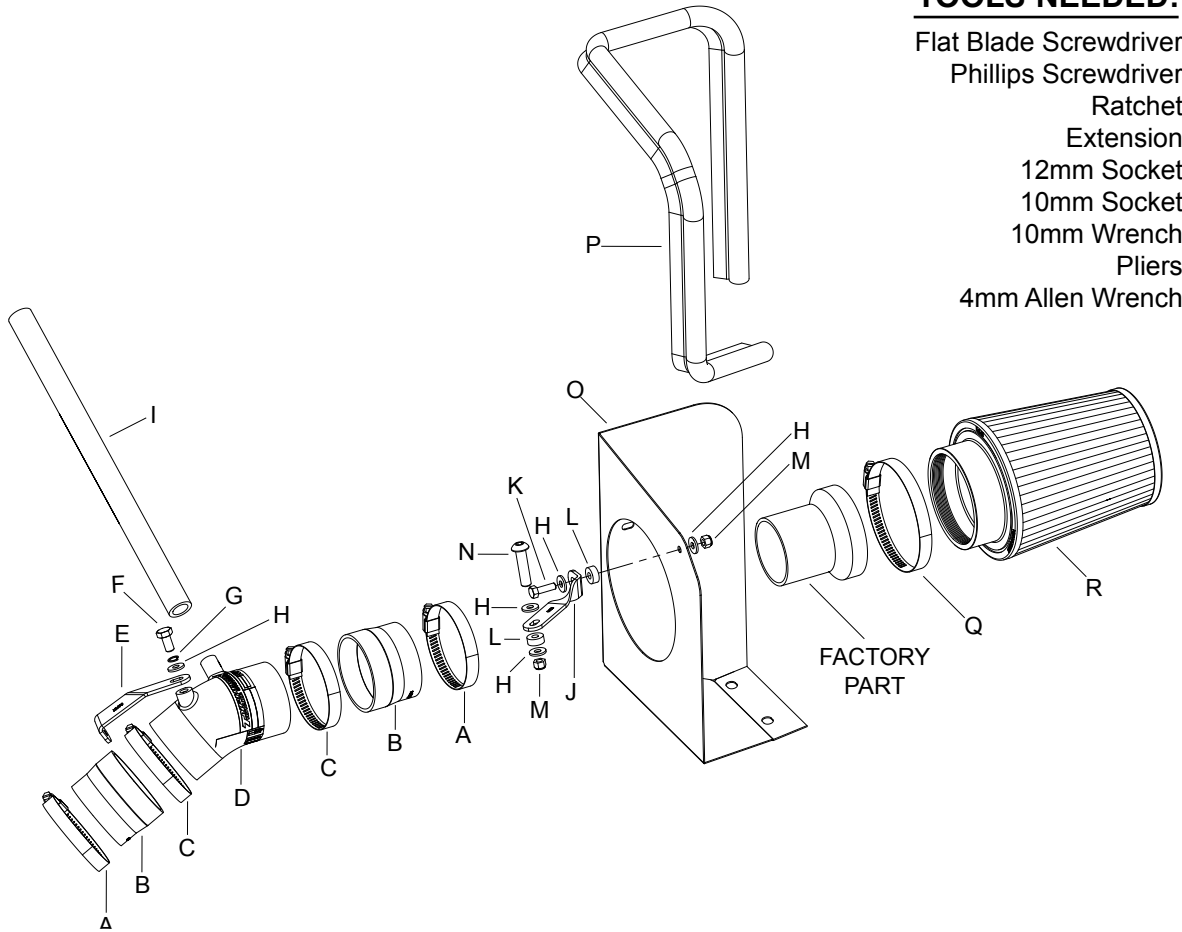

TOOLS NEEDED:

Flat Blade Screwdriver
 Phillips Screwdriver
 Ratchet
 Extension
 12mm Socket
 10mm Socket
 10mm Wrench
 Pliers
 4mm Allen Wrench

NOTE: FAILURE TO FOLLOW INSTALLATION INSTRUCTIONS AND NOT USING THE PROVIDED HARDWARE MAY DAMAGE THE INTAKE TUBE, THROTTLE BODY AND ENGINE.

TO START:

1. Turn off the ignition and disconnect the negative battery cable.

NOTE: Disconnecting the negative battery cable erases pre-programmed electronic memories. Write down all memory settings before disconnecting the negative battery cable. Some radios will require an anti-theft code to be entered after the battery is reconnected. The anti-theft code is typically supplied with your owner's manual. In the event your vehicles anti-theft code cannot be recovered, contact an authorized dealership to obtain your vehicles anti-theft code.



2. Lift the engine cover off of the mounting grommets and then remove the cover from the vehicle.



3. Depress the locking tab on the mass air sensor electrical connection and disconnect the electrical connector from the mass air sensor. Unhook the mass air sensor wiring harness from the mounting tabs on the air box.

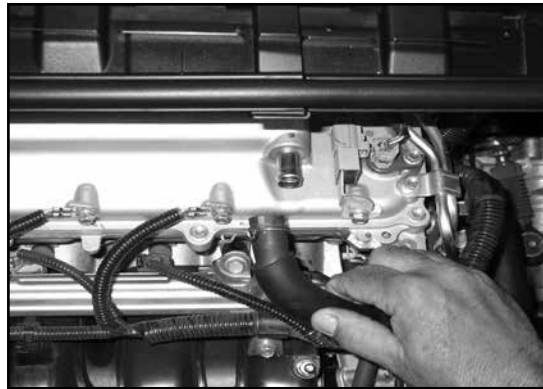

4. Release the spring clamp that secures the crank case vent hose to the valve cover. Then remove the crank case vent hose from the valve cover port as shown.



5. Loosen the hose clamp which secures the stock intake hose to the throttle body.



6. Release the two upper air box mounting clips and then remove the upper air box and intake tube assembly as shown.

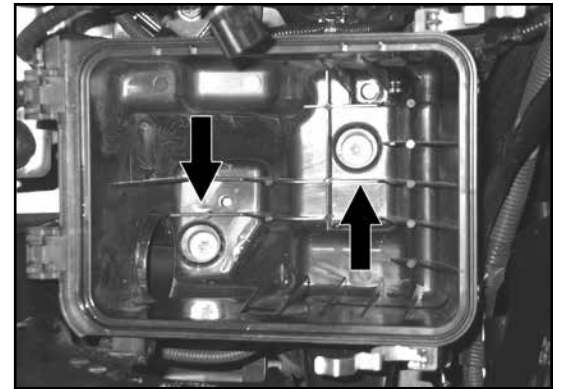

7. Remove the two lower air box mounting bolts shown.



8. Release the mass air sensor wiring harness from the lower air box and then remove the lower air box from the vehicle as shown.

NOTE: K&N recommends that customers do not discard factory air intake.

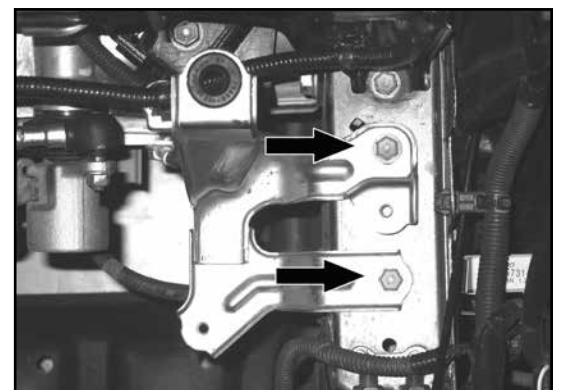

9. Remove the two bolts that secure the air box mounting bracket.

NOTE: These bolts will be reused in a later step.

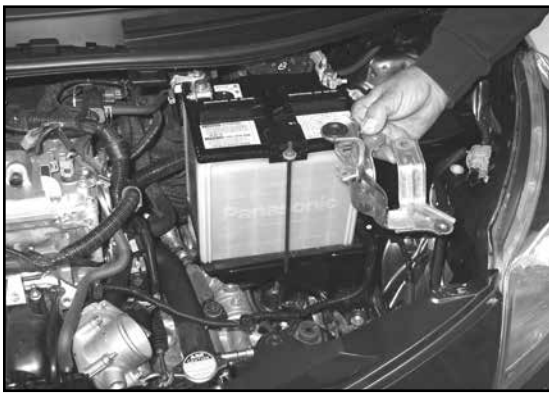

10. Unhook the mass air sensor wiring harness from the air box mounting bracket and then remove the air box mounting bracket from the vehicle.



11. Loosen the hose clamp that secures the stock intake hose to the mass air sensor. Disconnect the intake hose from the mass air sensor as shown.



12. Remove the two bolts that secure the mass air sensor to the upper air box and then remove the mass air sensor as shown.

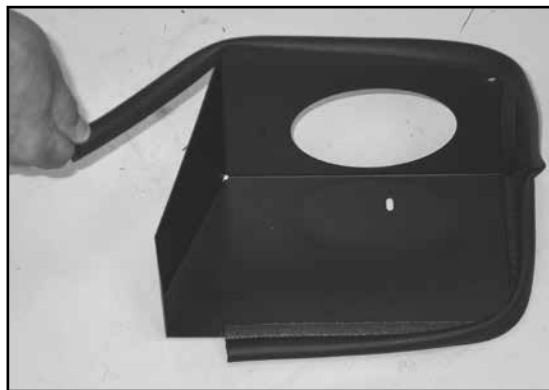

13. Install the provided edge trim onto the heat shield as shown.



14. Install the heat shield assembly into the engine compartment. Secure the heat shield assembly to the inner fender with the bolts removed in step #9. Attach the mass air sensor wiring harness clip to the heat shield provided by the hole in the heat shield.

NOTE: Be careful not to pinch any of the loose factory wiring harness under the heat shield.

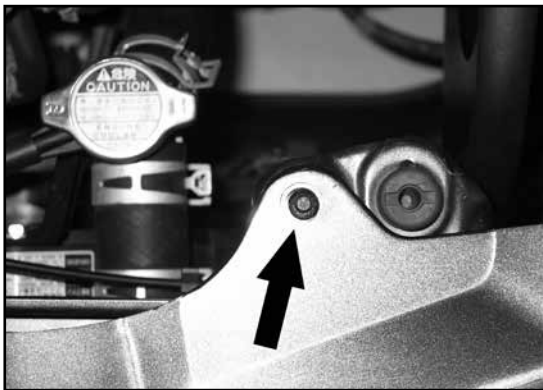

15. Remove the factory bumper cover mounting pin from the core support as shown.

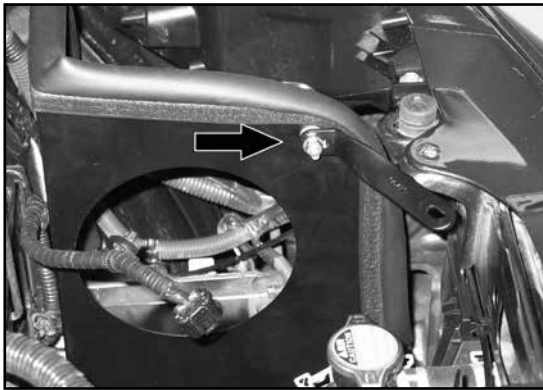

16. Attach the supplied heat shield bracket (06720) onto the heat shield as shown. Be sure to place one of the provided spacers between the heat shield and bracket.

NOTE: Do not completely tighten the mounting bolt at this time.

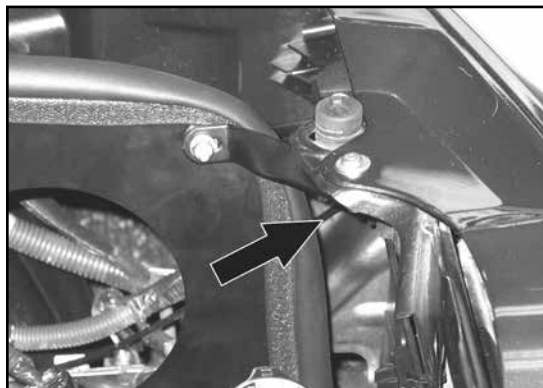

17. Attach the other end of the heat shield mounting bracket to the core support with the provided hardware. Be sure to place the remaining spacer between the bracket and under side of the core support.

NOTE: The mounting bolt will pass through the hole vacated by the bumper cover mounting pin from step #15.

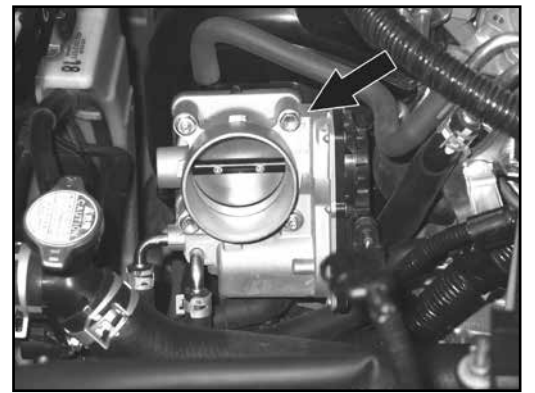

18. Remove the upper rear throttle body mounting bolt shown.

NOTE: This bolt will be reused in a later step.



19. Install the tube mounting bracket (06721) onto the throttle body and secure it with the bolt removed in the previous step (Step 18).

NOTE: Do not completely tighten the bracket at this time.



20. Install the supplied silicone hose (084014) onto the throttle body and secure it with the provided hose clamp.



21. Install the K&N® intake tube into the silicone hose on the throttle body and align with the mounting bracket installed during step #19. Secure the intake tube with the provided hardware.

NOTE: Do not completely tighten the intake tube in place at this time.



22. Install the remaining silicone hose (084014) onto the mass air sensor and secure it with the provided hose clamp.



23. Pass the mass air sensor assembly through the heat shield and secure it to the intake tube with the provided hose clamp as shown.

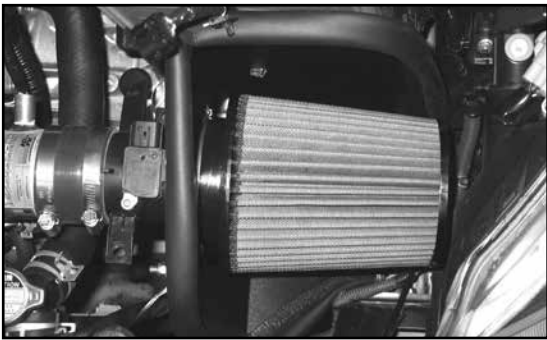

24. Install the K&N® Air Filter onto the mass air sensor and secure it with the provided hose clamp.

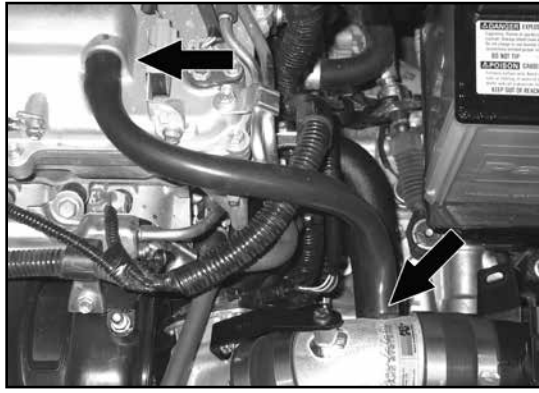

25. Install the supplied silicone hose onto the fitting on the valve cover. Attach the other end to the vent port on the K&N® intake tube.



26. Reconnect the mass air sensor electrical connection and secure the mass air sensor wiring harness to the mass air sensor housing.



27. Reinstall the engine cover assembly.



28. Reconnect the negative battery cable and double check to make sure everything is tight and properly positioned before starting the vehicle.

29. It will be necessary for all K&N® Performance Intake Kit's to be checked periodically for realignment, clearance and tightening of all connections. Failure to follow the above instructions or proper maintenance may void warranty.

ROAD TESTING:

1. Start the engine with the transmission in neutral or park, and the parking brake engaged. Listen for air leaks or odd noises. For air leaks secure hoses and connections. For odd noises, find cause and repair before proceeding. This kit will function identically to the factory system except for being louder and much more responsive.
2. Test drive the vehicle. Listen for odd noises or rattles and fix as necessary.
3. If road test is fine, you can now enjoy the added power and performance from your kit.
4. K&N suggests checking the air filter element periodically for excessive dirt build-up. When the element becomes covered in dirt (or once a year), service it according to the instructions on the Recharger service kit, part number 99-5000 or 99-5050.

LEGAL IN CALIFORNIA ONLY FOR RACING VEHICLES WHICH MAY NEVER BE USED, REGISTERED OR LICENSED FOR USE UPON A HIGHWAY.

See knfilters.com for CARB status on each part for a specific vehicle