



INTAKE SYSTEMS FOR VEHICLES LISTED ARE 50 STATE LEGAL. SEE KNFILTERS.COM FOR CARB STATUS ON EACH PART FOR A SPECIFIC VEHICLE.

INSTALLATION INSTRUCTIONS

57-3037
HUMMER
2003-09 H2
V8-6.2L/6.0L

NOTE: This kit was not designed to fit vehicles with a body lift.

TOOLS NEEDED:

- 4mm Allen Wrench
- 10mm Socket
- 8mm Wrench
- 10mm Wrench
- Flat Blade Screwdriver
- Socket Extension
- Ratchet

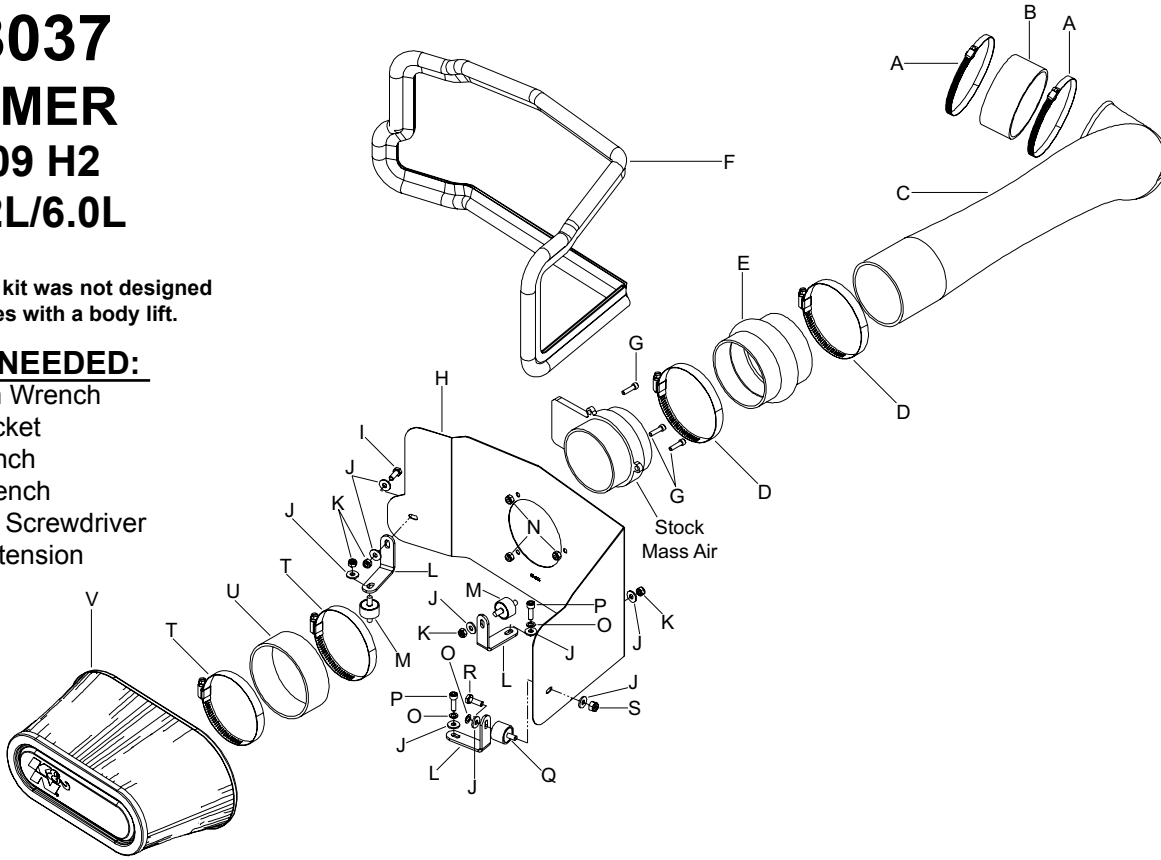

PARTS LIST:

Description	Qty.	Part #
A Hose Clamp #64 Midi	2	08650
B Silicone Hose	1	08755
C Intake Tube (CT)	1	087087-1
D Hose Clamp #56	2	08620
E Silicone Hump Hose	1	08176
F Edge Trim 61"L	1	102492
G Bolt; 5mm-0.8x10mm Allen	3	22205
H Heat Shield	1	074016
I Bolt 6mm-1.00x16MM Hex	1	07703
J Washer; 1/4"IDx5/8"OD Flat	9	08275
K 6mm Nylock Nut	4	07553
L Bracket "L"	3	070662
M M6 Rubber Mounted Stud	2	07027
N Nut M5-0.8 Nylock	3	07507
O Washer 6MM Wave	3	08174
P Bolt 6mm-1.00x20MM Allen	2	07852
Q Mounted Stud 3/4" Thick	1	070226
R Bolt 1/4"-20 Hex	1	08386
S Nut 1/4"-20 Nylock	1	07517
T Hose Clamp #60	2	08624
U Silicone Hose	1	08621
V Air Filter	1	RP-5103

NOTE: FAILURE TO FOLLOW INSTALLATION INSTRUCTIONS AND NOT USING THE PROVIDED HARDWARE MAY DAMAGE THE INTAKE TUBE, THROTTLE BODY AND ENGINE.

TO START:

1. Turn off the ignition and disconnect the negative battery cable.

NOTE: Disconnecting the negative battery cable erases pre-programmed electronic memories. Write down all memory settings before disconnecting the negative battery cable. Some radios will require an anti-theft code to be entered after the battery is reconnected. The anti-theft code is typically supplied with your owner's manual. In the event your vehicles' anti-theft code cannot be recovered, contact an authorized dealership to obtain your vehicles anti-theft code.



2. Remove the 8mm bolt that retains then engine cover onto the engine then remove the cover from vehicle.



3. Disconnect the mass air sensor electrical connection.



4. Loosen the hose clamp at the throttle body.

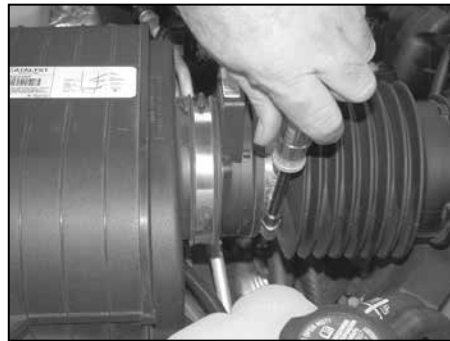

5. Loosen the hose clamp at the mass air sensor.



6. Detach the intake tube from the throttle body and mass air sensor then remove the intake assembly.

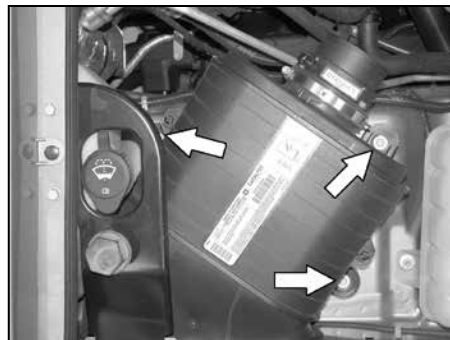

7. Remove the 3 10mm bolts that retain the air box onto the vehicle.



8. Remove the air box from vehicle as shown. **NOTE: K&N Engineering, Inc., recommends that customers do not discard factory air intake.**



9. Loosen the hose clamp that retains the mass air sensor onto the air box then remove the mass air sensor from the air box.

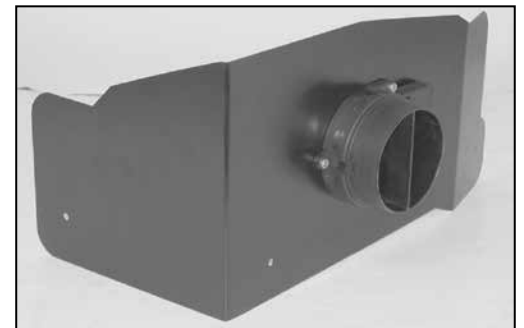

10. Install the mass air sensor onto the heat shield with the provided hardware.



11. Install the edge trim onto the heat shield. **NOTE: Some trimming of the edge trim may be necessary.**

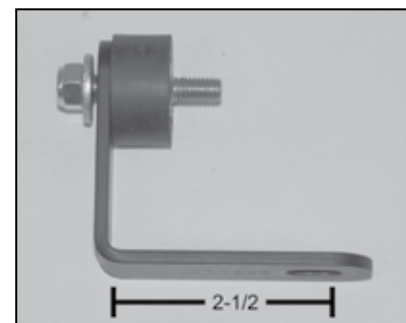

12. Install the 1/2 long rubber mounted stud onto bracket as shown.

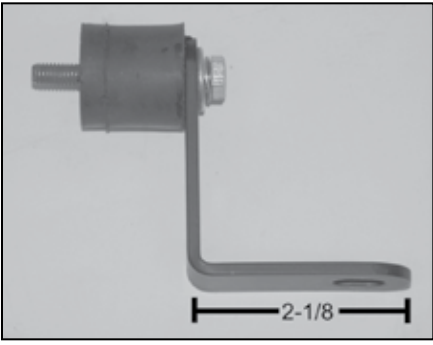

13. Install the 1" long rubber mounted stud onto bracket as shown.



14. Install the rubber mounted stud onto the vehicle as shown.

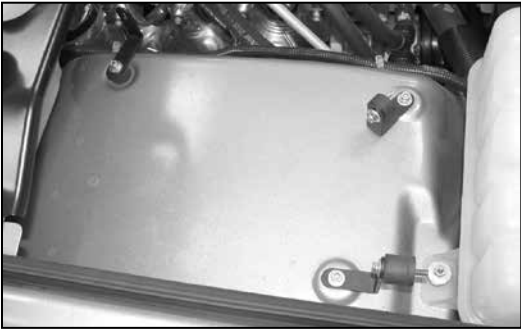

15. Install the 3 brackets onto the vehicle with the provided hardware as shown. Don't tighten completely at this time.



16. Install the silicone hump hose (08176) onto the mass air sensor with the provided hose clamps as shown.



17. Install the silicone hose (08621) on the inside of heat shield with the provided hose clamps.



18. Install the heat shield assembly into vehicle as shown.



19. Secure the brackets to the heat shield with the provided hardware. Do not tighten completely.

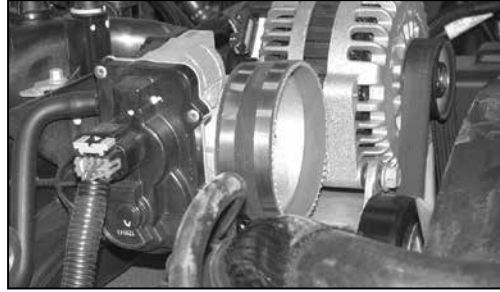

20. Install the provided silicone hose (08755) onto the throttle body with provided hose clamps.



21. Install the intake tube onto the vehicle; then align the tube with the mass air sensor and then tighten hose clamp.



22. Align the intake tube with the throttle body then tighten the hose clamps.

NOTE: Check intake tube for best clearance and make adjustments if needed.



23. Install the air filter onto the mass air sensor and then tighten hose clamp.



24. Reconnect the mass air electrical connection as shown.



25. Reconnect the vehicle's negative battery cable. Double check to make sure everything is tight and properly positioned before starting the vehicle.

26. The C.A.R.B. exemption sticker, (attached), must be visible under the hood so that an emissions inspector can see it when the vehicle is required to be tested for emissions. California requires testing every two years, other states may vary.

27. **NOTE:** Most General Motors vehicles have the Vehicle Emissions Certification Information (VECI) label affixed to the air filter box. In order to be compliant with California emissions laws, the label **MUST** remain in the engine compartment. If the Vehicle Emission Control Information label is removed during modification, a new replacement label must be obtained and installed in a readily visible position in the engine compartment. The label shall not be affixed to any equipment which is easily detached from the vehicle. We recommend that the label is affixed to the underside of the hood adjacent to the hood latch. The label is Vehicle Identification Number dependent and can be ordered from the vehicle dealership. In order to receive the proper decal please bring your VIN with you. Failure to have the VECI under the hood may result in failure of a pre-registration smog test.

28. It will be necessary for all K&N® high flow intake systems to be checked periodically for realignment, clearance and tightening of all connections. Failure to follow the above instructions or proper maintenance may void warranty.

ROAD TESTING:

1. Start the engine with the transmission in neutral or park, and the parking brake engaged. Listen for air leaks or odd noises. For air leaks secure hoses and connections. For odd noises, find cause and repair before proceeding. This kit will function identically to the factory system except for being louder and much more responsive.

2. Test drive the vehicle. Listen for odd noises or rattles and fix as necessary.

3. If road test is fine, you can now enjoy the added power and performance from your kit.

4. K&N Engineering, Inc., requires cleaning the intake system's air filter element every 100,000 miles. When used in dusty or off-road environments, our filters will require cleaning more often. We recommend that you visually inspect your filter once every 25,000 miles to determine if the screen is still visible. When the screen is no longer visible some place on the filter element, it is time to clean it. To clean and re-oil, purchase our filter Recharger® service kit, part number 99-5050 or 99-5000 and follow the easy instructions.

INTAKE SYSTEMS FOR VEHICLES LISTED ARE 50 STATE LEGAL. SEE KNFILTERS.COM FOR CARB STATUS ON EACH PART FOR A SPECIFIC VEHICLE.