



FUEL INJECTION PERFORMANCE KIT FIPK

INTAKE SYSTEMS FOR VEHICLES LISTED ARE 50 STATE LEGAL. SEE KNFILTERS.COM FOR CARB STATUS ON EACH PART FOR A SPECIFIC VEHICLE.

INSTALLATION INSTRUCTIONS

57-1503-1

DODGE

94-00 Ram

V6-3.9L

NOTE: FAILURE TO FOLLOW INSTALLATION INSTRUCTIONS AND NOT USING THE PROVIDED HARDWARE MAY DAMAGE THE THROTTLE BODY AND ENGINE.

PARTS LIST:

Desc.	Part #	Qty.
A 1/4" Nylock nut	07517	1
B Washer	08151	1
C Rubber washer	21708	1
D Top plate	06842	1
E Filtercharger® element	E-3740E	1
F Base plate	01545	1
G Hose clamp	08411	1
H Base gasket	09988	1
I 1/4" X 4.5" bent stud	08008	1
J Wire ties	21638	2

INSTALLATION

See the figure below for stock part locations.

See the exploded view for finished kit locations.

- 1) Disconnect the vehicle's negative battery cable.
- 2) Remove the vent hose at stock airbox and remove the entire airbox housing and intake tube along with the base gasket.
- 3) The wire loom must be zip tied out of the way to install the K&N assembly.
- 4) Install the new gasket, base plate and filter to the throttle body. (see exploded view). You will need to cut the stock vent hose and secure it to the fitting. (use supplied hose clamp)
- 5) Install the provided "Z" stud to the throttle-body.
- 6) Install the lid and provided hardware.
- 7) Position for best clearance and tighten all hardware. Make sure that the wire loom is not touching or rubbing against the top plate or the "Z" stud and nut.
- 8) Re-connect battery cable. Double check to make sure everything is tight and properly positioned before starting vehicle.
- 9) The C.A.R.B. exemption sticker, (attached), must be placed in a visible area under the hood so that an emissions inspector can see it when the vehicle is required to be tested for emissions. California requires testing every two years, other states may vary.
- 10) It will be necessary for all FIPK's to be checked periodically for realignment, clearance and tightening of all connections. Failure to follow the above instructions or proper maintenance may void warranty.

ROAD TESTING:

1. Start the engine with the transmission in neutral or park, and the parking brake engaged. Listen for air leaks or odd noises. For air leaks secure hoses and connections. For odd noises, find cause and repair before proceeding. This kit will function identically to the factory system except for being louder and much more responsive.
2. Test drive the vehicle. Listen for odd noises or rattles and fix as necessary.
3. If road test is fine, you can now enjoy the added power and performance from your kit.
4. K&N suggests checking the Filtercharger element periodically for excessive dirt build-up. When the element becomes covered in dirt (or once a year), service it according to the instructions on the Recharger service kit, part number 99-5050 or 99-5000.

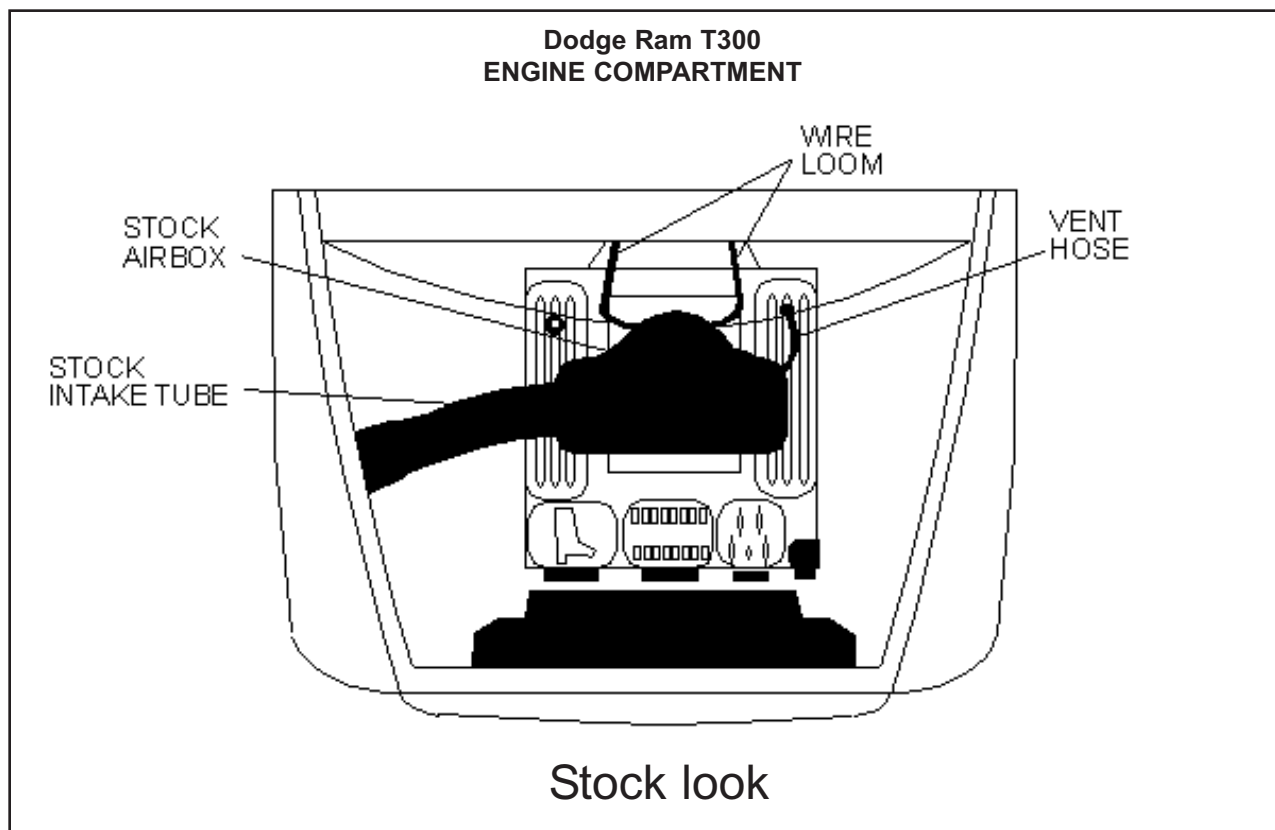
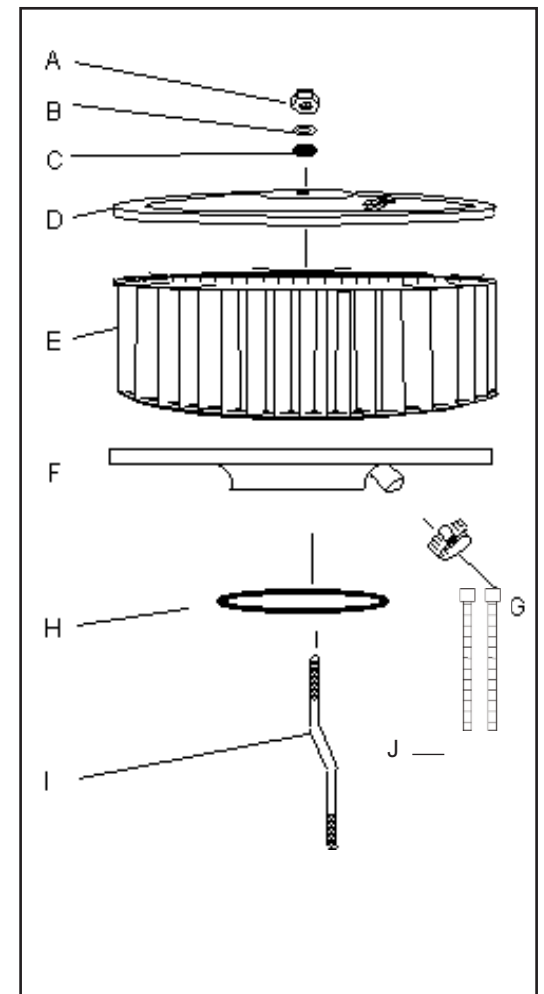

INTAKE SYSTEMS FOR VEHICLES LISTED ARE 50 STATE LEGAL. SEE KNFILTERS.COM FOR CARB STATUS ON EACH PART FOR A SPECIFIC VEHICLE.

FREE K&N DECAL To register your warranty, please see us online at knfilters.com/register. FREE K&N DECAL

