

PLEASE READ THE INSTRUCTIONS CAREFULLY BEFORE FITTING THE KIT.**If you have a problem, however small, call our Technical Department.**

Tel:- 01925 636950. Fax:- 01925 243111 . Mon to Fri 8.30 - 5pm. Fri 8.30 - 1pm

- 1 Remove the complete air box assembly, including the warm air hose, by removing the four screws indicated on the air box cover.
- 2 Remove the breather hose from the air box base.
- 3 Remove the black plastic pipe running from the inner wing and exhaust manifold to the air box. **Drawing A**
- 4 Fit the 90 degree plastic elbow into the end of the breather hose supplied. Unclip the standard breather hose and push the new hose approximately 2cm into it.
- 5 Push the breather mounted elbow into the hole in the filter base. **Drawing B**
- 6 Clean and degrease the neck before fitting the filter. Clamp the filter unit to the intake manifold neck ensuring that the clamp does not interfere with the throttle opening. Adjust the filter until the K&N logo is straight before tightening in place. Tighten the clip until the filter just rotates, then give one full turn (360 degrees). No more. **Don't overtighten the clips**. **Drawing C**
- 7 **Cold air system**
Carefully expand the flexi cold air hose to approximately 110cm / 43" length.
- 8 **Late models** with three separate lower grilles: Feed the cold air hose to the right hand side of the centre lower grille section taking care to avoid the alternator drive belt. Pierce two small (approximately 4mm) holes in the end of the hose and tie to the grille using the two medium plastic ties supplied. Proceed to step 11. **Drawing D**.
- 9 Feed the cold air hose down to the lower grille, taking care to avoid the alternator drive belt. Tie the hose to the metal bracket using the long tie supplied. Replace the lower grille. **Drawing E**.
- 10 Secure the cold air hose to finish approximately **10cm / 4"** from the filter (**no nearer**). **Drawing F**.
- 11 **Tuning.**
CAT. Cars. No adjustments are required.
An increase in fuel mixture may be required if further modifications are carried out.
- 12 **Filter maintenance.**
Under normal conditions clean and reoil the filter at approx. 40,000 miles / 65,000 Km.
Use only K&N cleaner and oil and follow the instructions carefully.

K&N filters are pre-oiled ready to fit.**The advantage's of K&N's cold air intake system.**

Cooler air being denser, will show positive improvements in power over filter systems that draw hot air from the engine bay.

With screws removed the **complete** air intake assembly can be removed

TOP VIEW

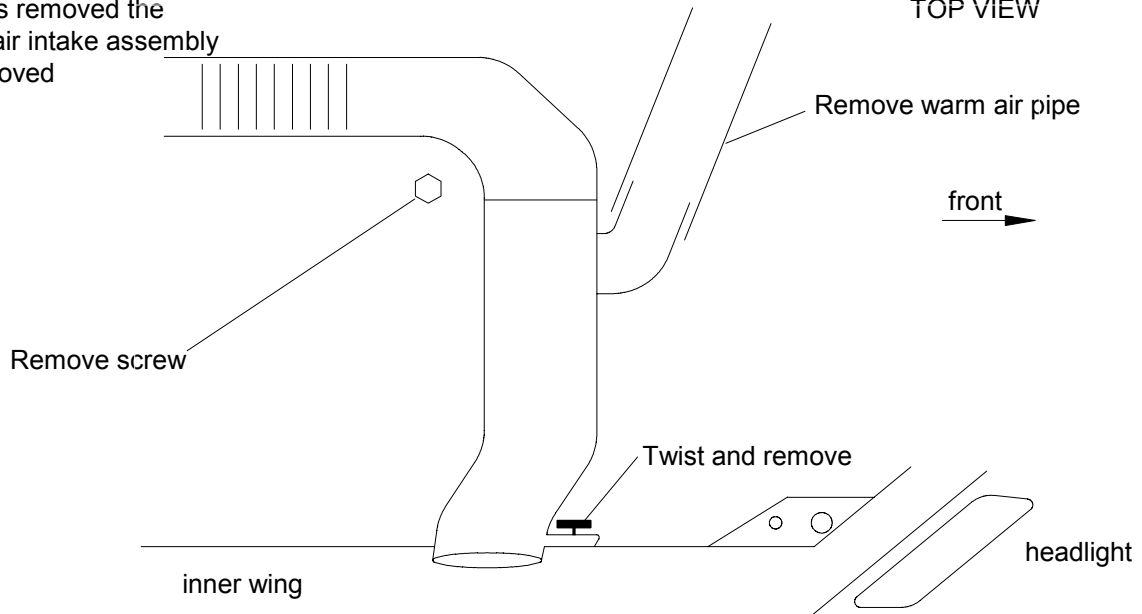

Drawing B

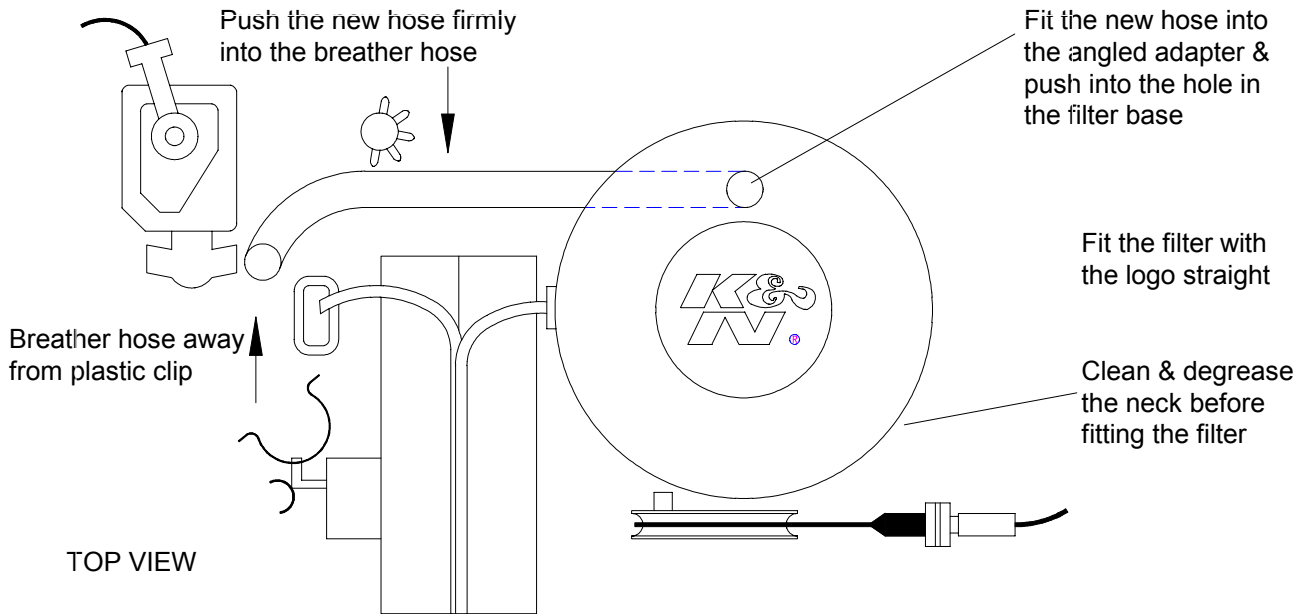

Drawing C

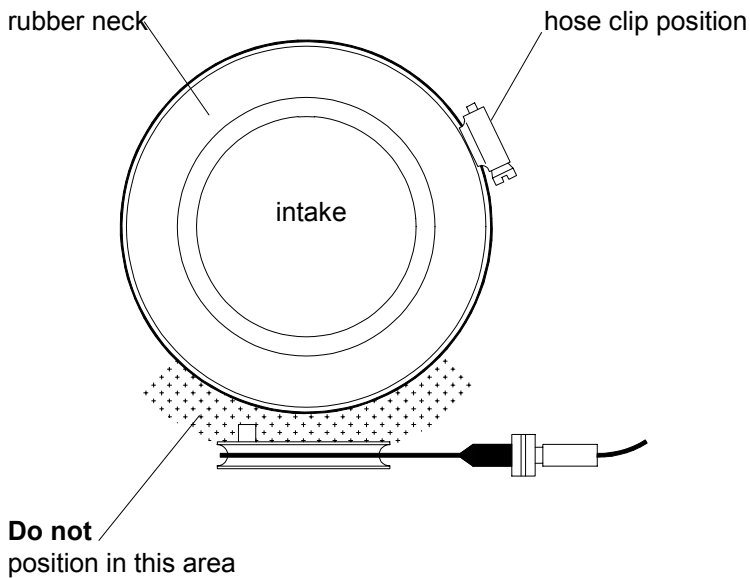

Drawing D

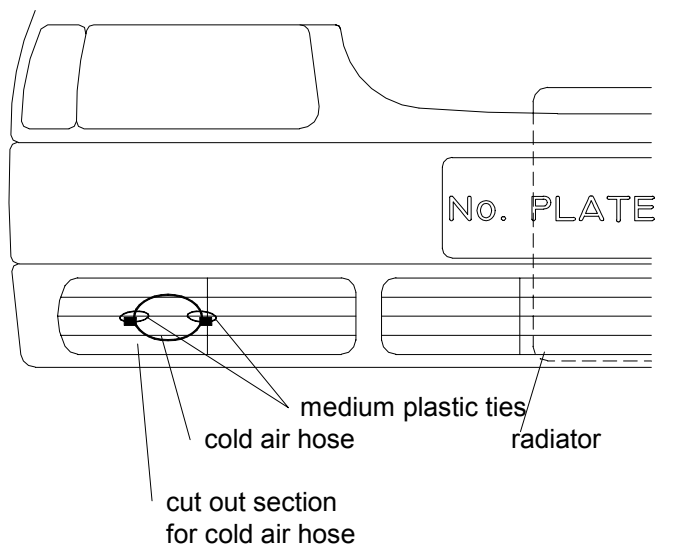

Drawing E

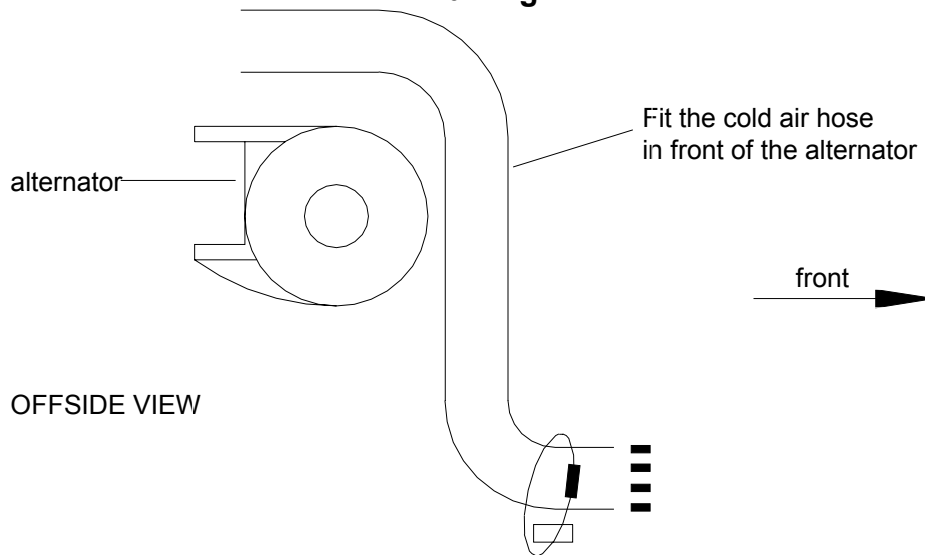

Drawing F

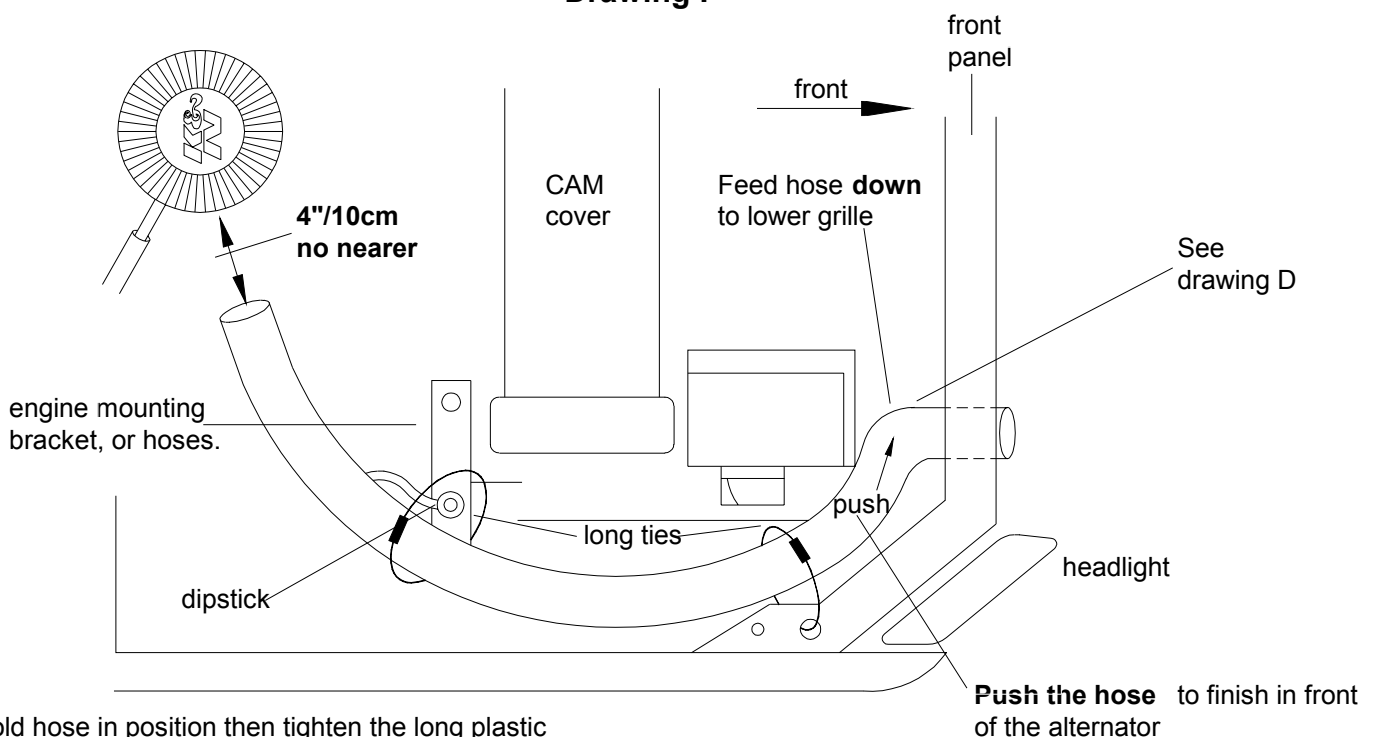

Hold hose in position then tighten the long plastic tie to stop the hose moving towards the pulley

This Kit Should Contain:

- 1 x Clamp on filter
- 1 x #40 Hose Clip
- 1 x Cold Air Hose Assembly
- 1 x Breather hose
- 1 x Instruction Sheet
- 1 x Instruction Pack :-
 - 1 x Filter Maintenance Sheet
 - 1 x K&N Window Sticker
 - 1 x Million Mile Warranty
 - 1 x Leaflet
- 1 x Fixing Kit :-
 - 1 x Plastic angled tube
 - 3 x Cable ties (35cm long)
 - 2 x Cable ties (19cm long)

FITTING YOUR OWN 57i KIT

If not **it is essential** that the person fitting the kit (e.g. mechanic **carefully follows these particular instructions** even if he has fitted K&N kits before. This will save you both time and money. kits incorrectly fitted may show a loss in performance e.g. the positioning of the essential cold air hose, (flexi expandable and rubber hoses are used).

A final check under the bonnet, by yourself with the instructions, would seem sensible