

**PLEASE READ THESE INSTRUCTIONS CAREFULLY BEFORE FITTING THIS KIT**

**If you have a problem, however small, call our Technical Department**

Tel:- 01925 636950. Fax:- 01925 243111. Mon - Thurs 8.30 - 5pm.

**Drawing A**

TOP VIEW

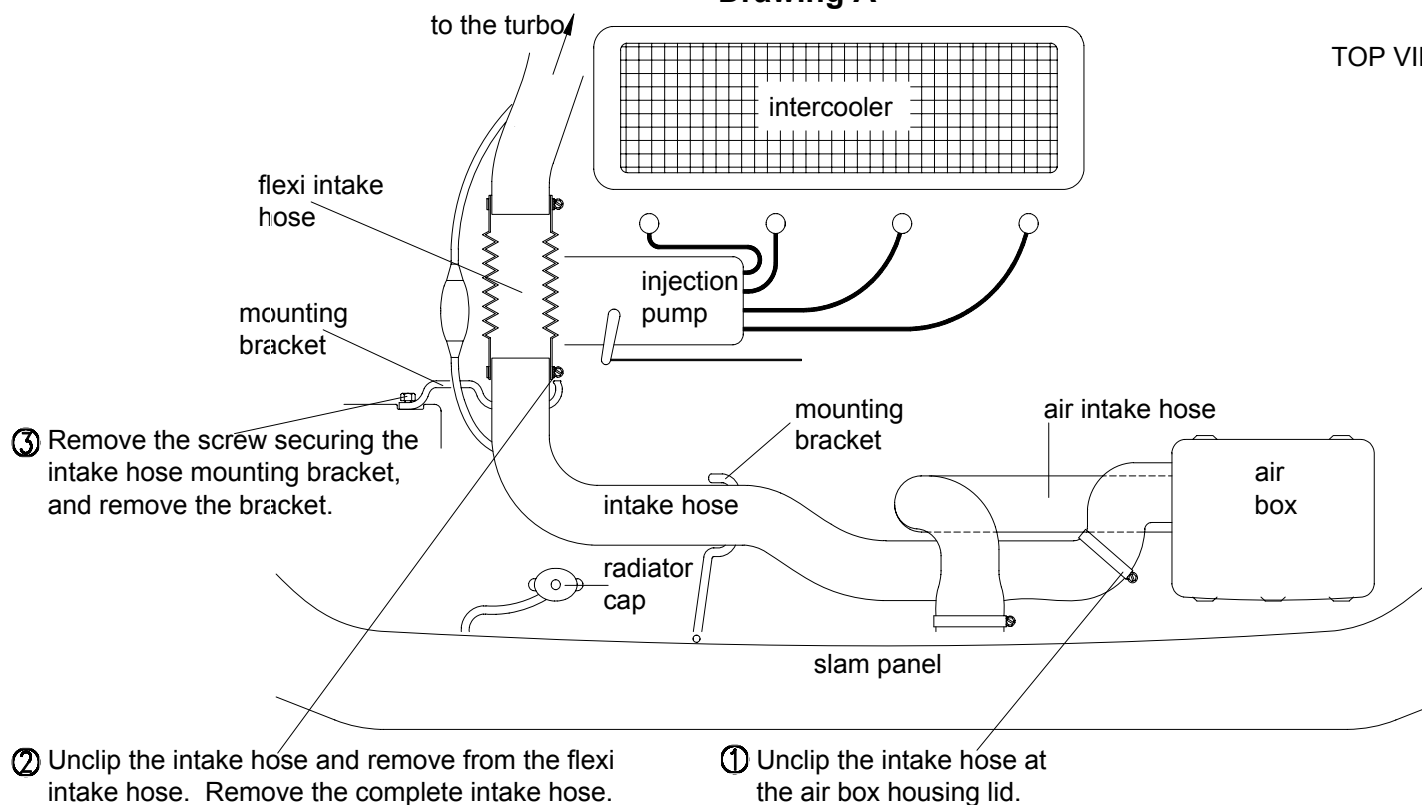

**Drawing B**

TOP VIEW

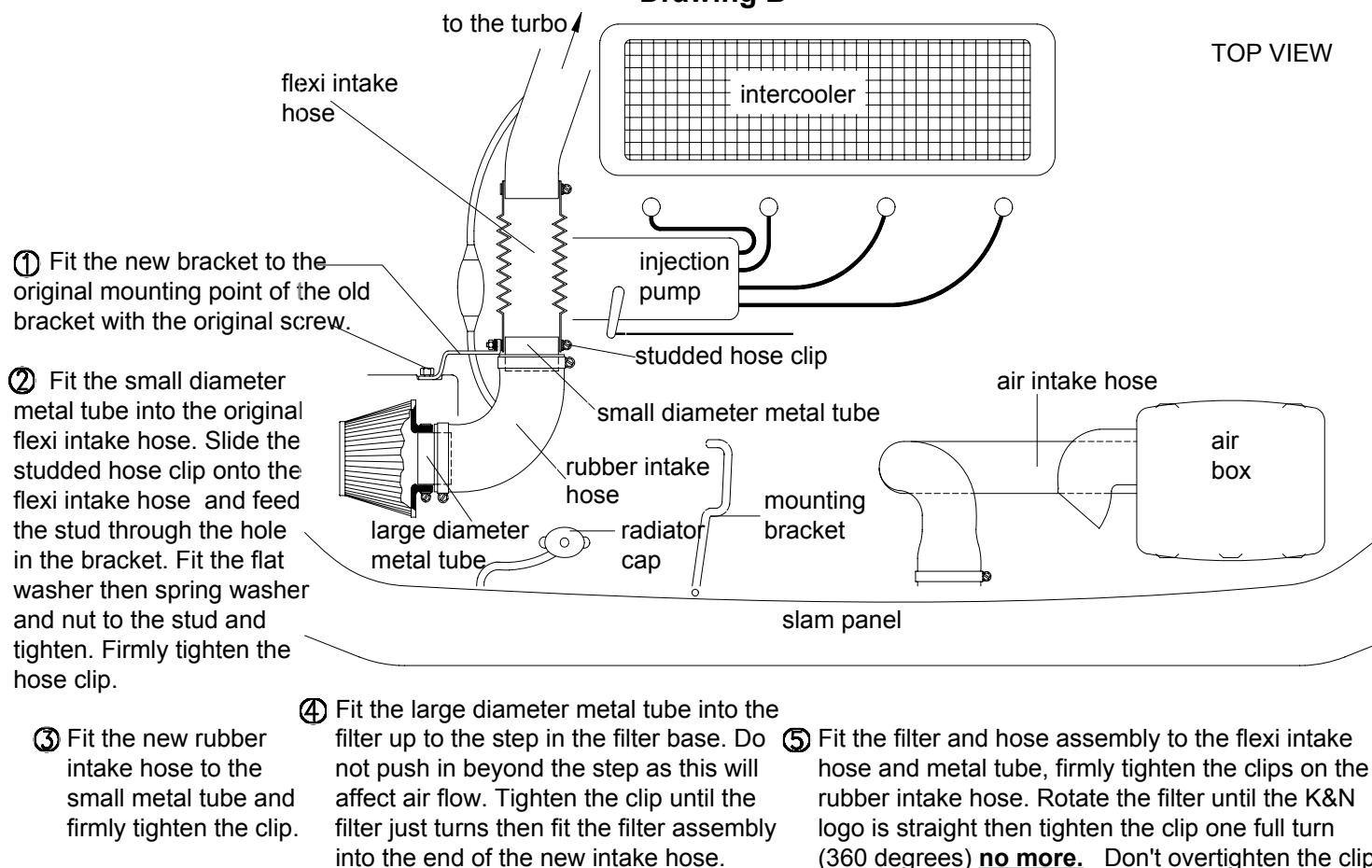

TOP VIEW

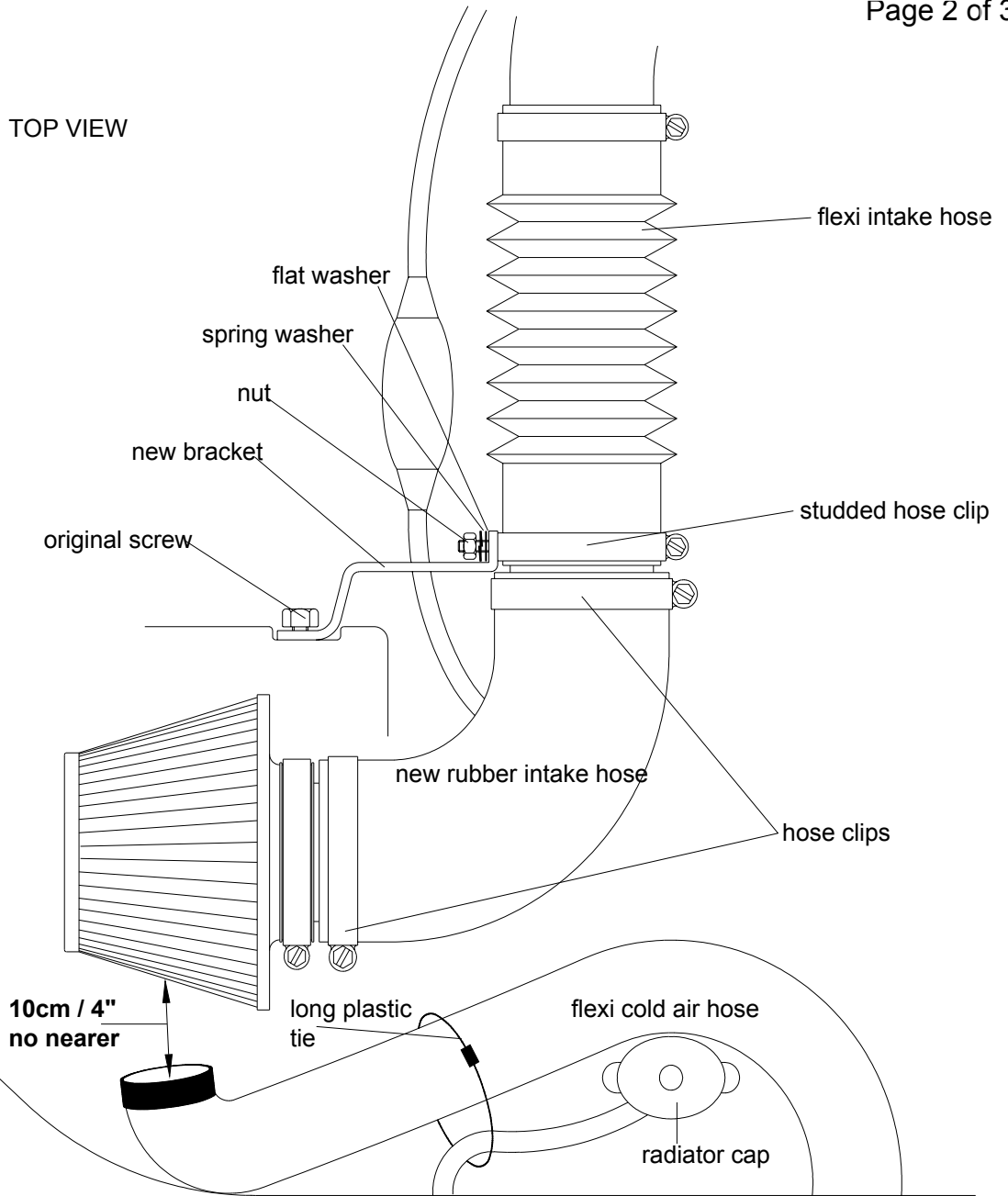

Lengthen the flexi cold air hose to 84cm / 33". Feed the cold air hose down between the engine and radiator to the front R.H.S. lower bumper. Use a long plastic tie to attach the cold air hose to the coolant hose coming from the radiator cap.

10cm / 4"  
no nearer

Drawing D

FRONT VIEW

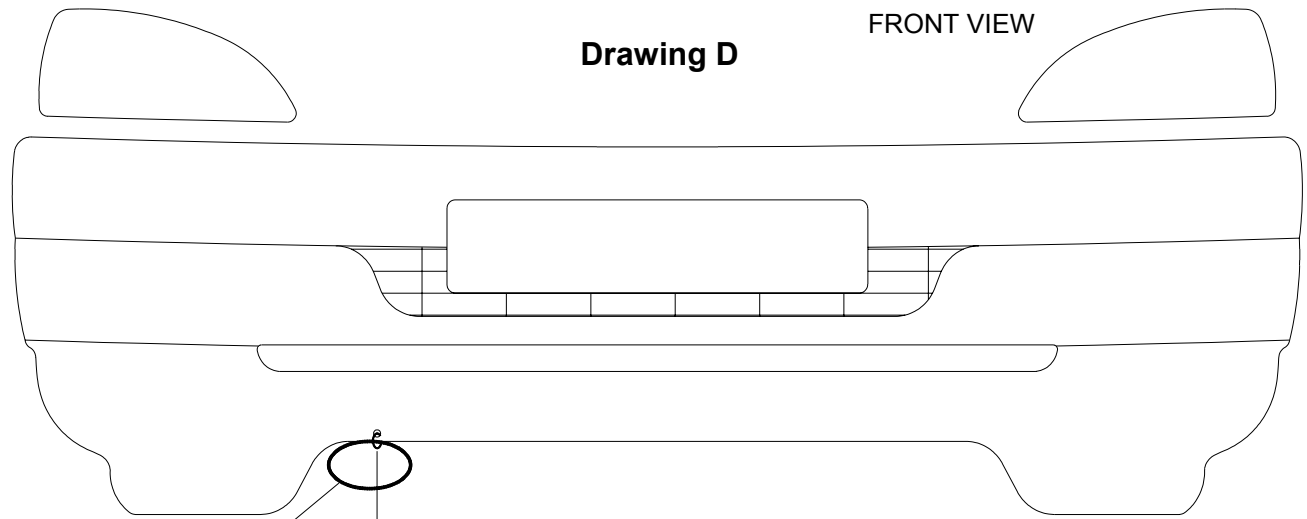

flexi cold air hose  
medium plastic tie

Ovalise the bottom end of the flexi cold air hose, then pierce / drill a 3mm hole in the front lower bumper and also the end of the cold air hose. Attach the hose to the bumper with the medium plastic tie.

**Tuning.****CAT. Cars** No adjustments required

An increase in fuel mixture may be required if further modifications are carried out.

**Filter Maintenance.**

Under normal conditions clean and reoil the filter at approx. 40,000 miles / 65,000km.

**Use only K&N cleaner and oil** and follow the instructions carefully.**K&N filters are pre-oiled ready to fit****The advantage of K&N's cold air intake system.**

Cooler air being denser, will show positive improvements in power over filter systems that draw hot air from the engine bay.

This Kit Should Contain:

- 1 x Air Filter
- 1 x Hose Clip #48
- 1 x Cold Air Hose Assembly
- 1 x Rubber Intake Hose
- 1 x Bracket
- 1 x Small Metal Tube
- 1 x Large Metal Tube
- 1 x Instruction Sheet
- 1 x Instruction Pack :-
  - 1 x Filter Maintenance Sheet
  - 1 x K&N window sticker
  - 1 x Million Mile Warranty
  - 1 x Leaflet
- 1 x Fixing Kit :-
  - 1 x #40 Hose clip
  - 1 x #48 Hose clip
  - 1 x Studded Hose clip
  - 1 x M6 Nut
  - 1 x M6 Washer
  - 1 x 6mm Spring Washer
  - 1 x Long Cable Tie
  - 1 x Medium Cable Tie

**FITTING YOUR OWN 57i KIT**

If **not it is essential** that the person fitting the kit (e.g. mechanic) **carefully follows these particular instructions** even if he has fitted K&N kits before. This will save you both time and money. kits incorrectly fitted may show a loss in performance e.g. the positioning of the essential cold air hose, (flexi expandable and rubber hoses are used).

**A final check** under the bonnet, by yourself with the instructions, would seem sensible