

PLEASE READ THE INSTRUCTIONS CAREFULLY BEFORE FITTING THE KIT.**If you have a problem, however small, call our Technical Department.**

Tel:- 01925 636950. Fax:- 01925 418948. Monday to Friday 9am - 5pm.

- 1 Remove the air box lid and standard air filter.
- 2 Remove the three cap head screws in the filter box base.
- 3 Remove the three nylock nuts. (Push rags into the intake neck in order to prevent the nuts from dropping into the manifold.)
- 4 Remove the standard intake hose, running from the inner wing and exhaust manifold to the air box. **Drawing A.**
- 5 Remove the breather hoses from the air box base, and the complete air box assembly
- 6 Block the small breather hose running into the rear of the throttle body. **Drawing B.**
- 7 Insert the plastic elbow into the large breather hose and then into the filter. **Drawing C.**
- 8 **IMPORTANT. KEEP HOSE AND PLASTIC PIPE CLEAR OF THE THROTTLE ASSEMBLY.** **Drawing C.**
- 9 Clamp the filter to the throttle body, rotating clockwise until the breather hose is clear of the throttle assembly. Tighten the clip until the filter just rotates, then give one full turn (360 degrees). No more. The K&N logo should be straight.
- 10 **Cold air system**
Expand the cold air hose to 110cm / 43" length.
- 11 Press down to release the six retaining clips on the lower grille. **Drawing D.**
- 12 Cut corresponding air supply holes in the lower grille. **Drawing D**
- 13 Feed the hose down to the lower grille, taking care to avoid the alternator drive belt. **Drawing E.**
- 14 Secure the cold air hose as per **Drawing F**
- 15 Replace the lower grille.
- 16 **Tuning.**
CAT. Cars. No adjustments are required.
An increase in fuel mixture may be required if further modifications are carried out.
- 17 **Filter maintenance.**
Under normal conditions clean and reoil the filter at approx. 40,000 miles / 65,000 Km.
Use only K&N cleaner and oil and follow the instructions carefully.

K&N filters are pre-oiled ready to fit.**The advantage's of K&N's cold air intake system.**

Cooler air being denser, will show positive improvements in power over filter systems that draw hot air from the engine bay.

This Kit Should Contain

- 1 x Clamp-on Filter
- 1 x Hose Clip 100/120
- 1 x Cold Air Hose Assembly
- 1 x Instruction Sheet
- 1 x Instruction Pack:-
 - 1 x K & N Window Sticker
 - 1 x Filter Maintenance Sheet
 - 1 x Million Mile Warranty
 - 1 x Leaflet.
- 1 x Fixing Kit containing:-
 - 1 x M5 bolt
 - 3 x Cable Ties (35cm long)
 - 1 x Plastic elbow

**IMPORTANT INSTRUCTIONS
FOR ROUND ENTRY
CLAMP ON AIR FILTERS**

Gently tighten the hose clip to the point where the filter will just rotate on the pipe or intake flange. Reposition the K&N logo straight, then **give the clip two turns i.e. 360 , no more.**

FITTING YOUR OWN 57i KIT

If not, **it is essential** that the person fitting the kit (e.g. mechanic) **carefully follows these particular instructions** even if he has fitted K&N kits before. This will save you both time and money. Kits incorrectly fitted may show a loss in performance e.g. the positioning of the essential cold air hose, (flexi expandable and rubber hoses are used).

A final check under the bonnet, by yourself, with the instructions, would seem sensible.

With screws removed the **complete** air intake assembly can be removed

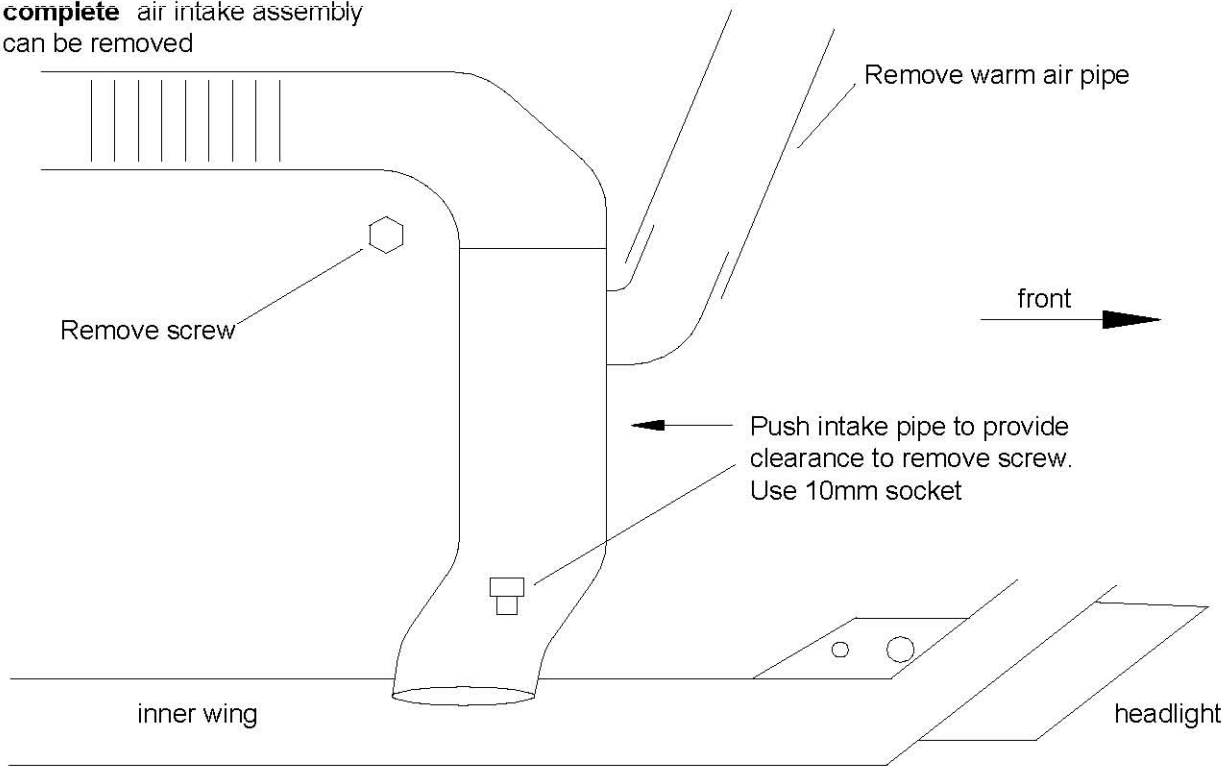

Drawing B

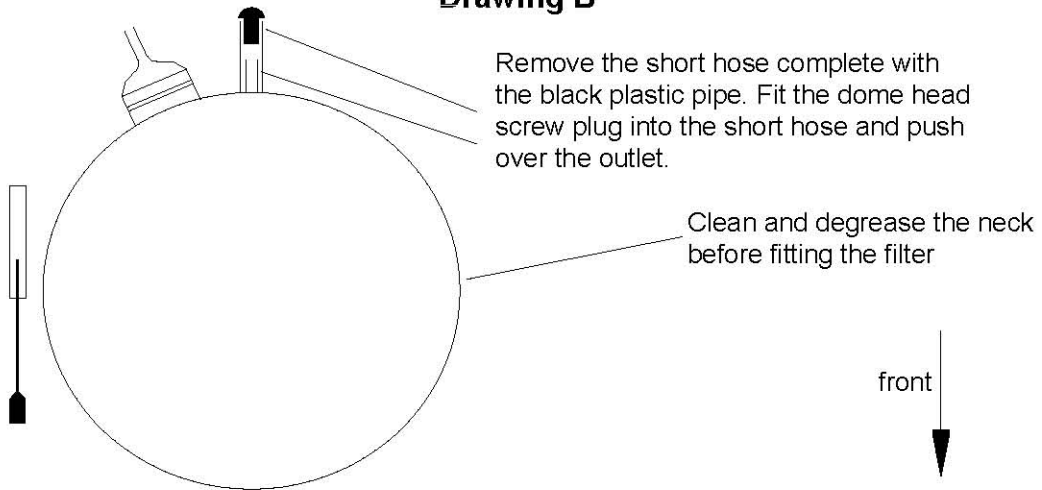

Drawing C

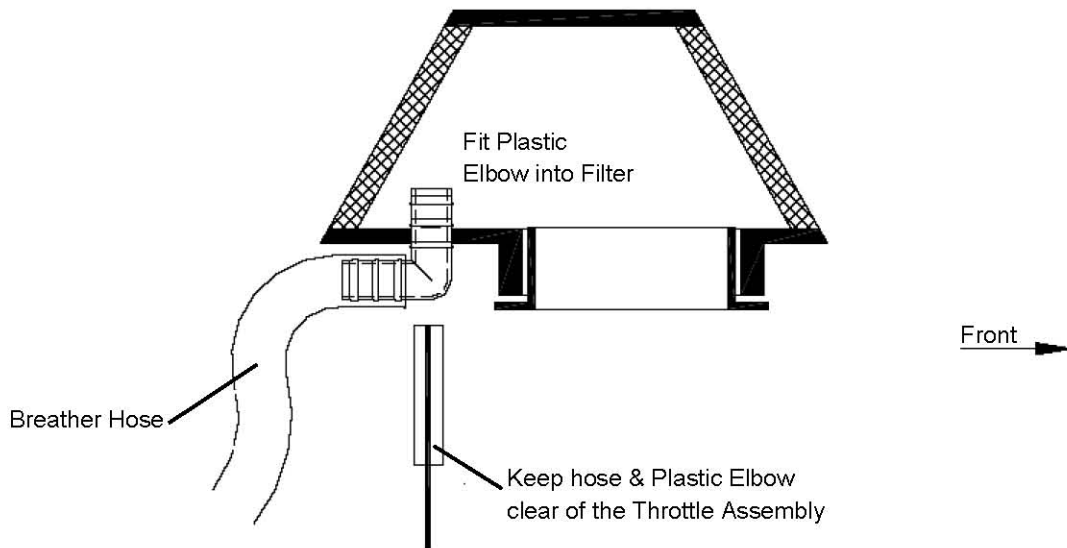

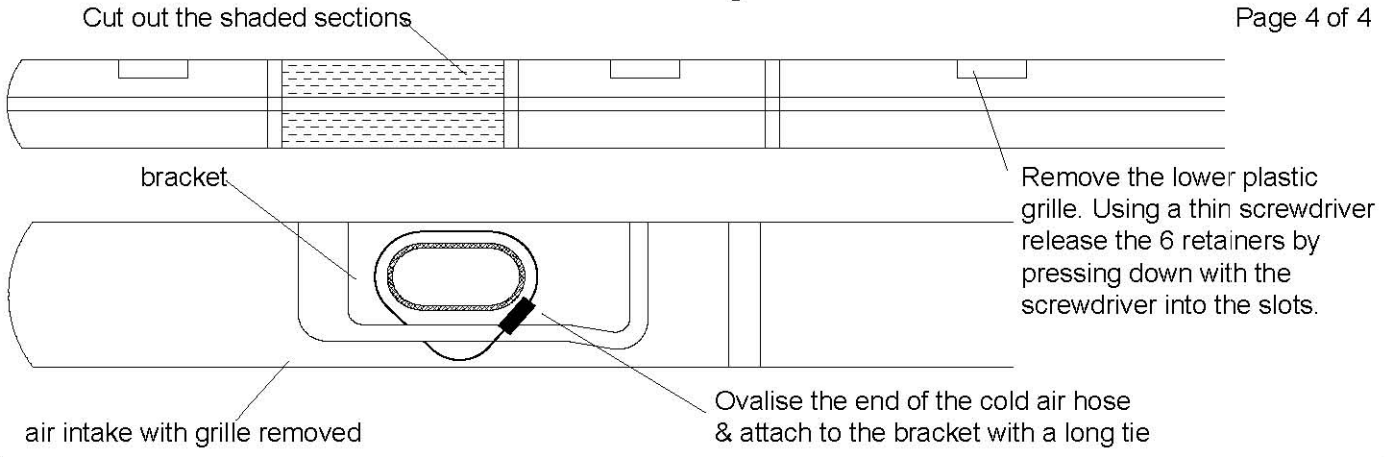

Drawing E

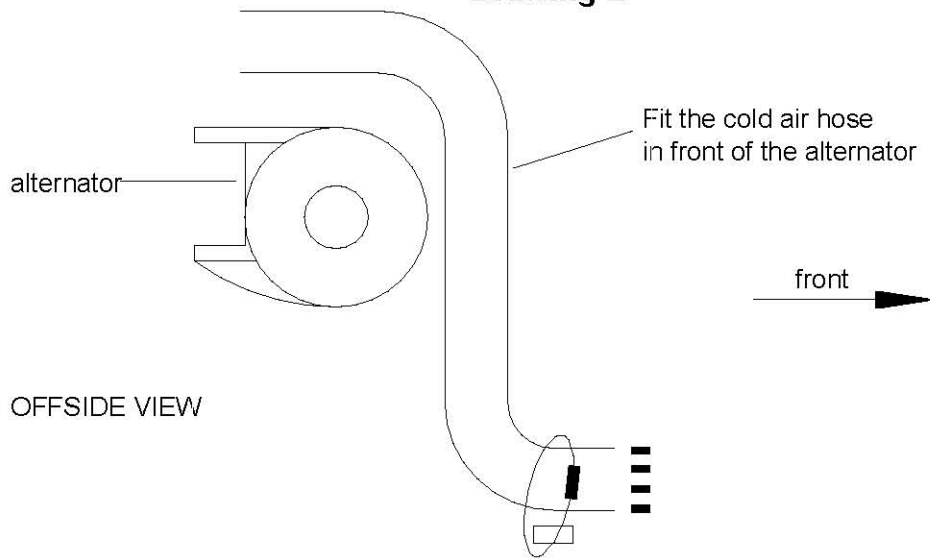

Drawing F

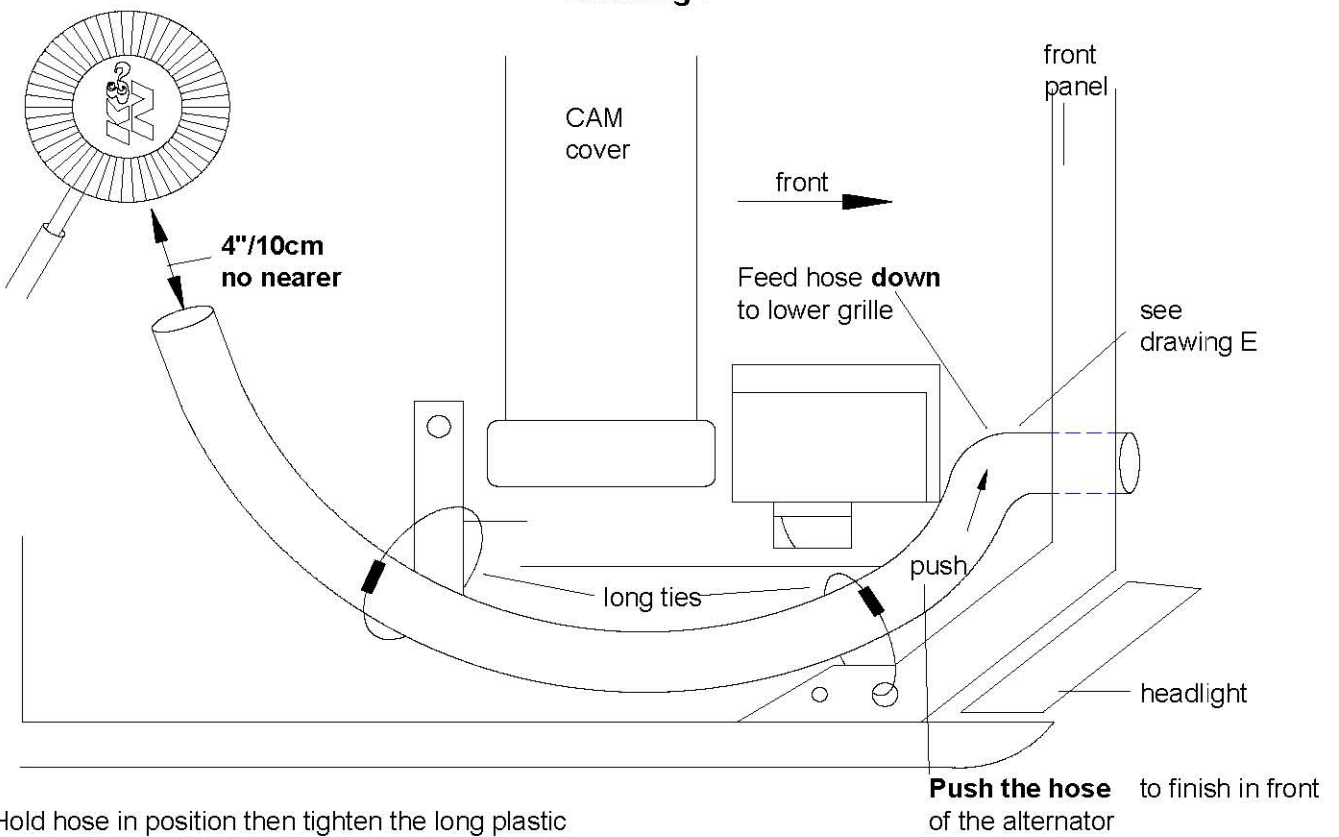

Hold hose in position then tighten the long plastic tie to stop the hose moving towards the pulley