



Equipped with AEM® Dryflow™ Filter  
No Oil Required!

## INSTALLATION INSTRUCTIONS

### PART NUMBER:21-8208

---

2009-2010	CHRYSLER	300C	V8-5.7L	SEE * NOTE
2005-2008	CHRYSLER	300C	V8-5.7L	C.A.R.B. E.O. # D-670
2006-2008	DODGE	Charger	V8-5.7L	C.A.R.B. E.O. # D-670
2005-2008	DODGE	Magnum	V8-5.7L	C.A.R.B. E.O. # D-670

\* **NOTE: Legal in California only for racing vehicles which may never be used upon a highway**

## PARTS LIST

Description	Qty.	Part Number
Air Filter Assy. 3.50 X 5" Dry Ele.	1	21-204DK
Inlet Pipe	1	2-82081
Heat Shield	1	20-P4510832
Hose, Silicone 3.50x2" Black	1	5-351
Edge Trim, 10"	1	8-4010
Mount, Rubber 1" X 8mm	1	1228560
Grommet, 1/2"	1	784634
Connector, Plastic 1/2" Blk.	1	8-117
Clip, Plastic Push In 0.300"	1	8-149
Hose; 1/2"ID X 2"L	1	5-5002
Washer, 8mm Soft Mount	2	559960
Nut, M8 Hex Serrated	2	444.460.08
1/2" Bnd. Hose Clamp, 3.15"-4.00"	3	9456
Hose Clamp, 1"	1	99024.032

Read and understand these instructions **BEFORE** attempting to install this product. Failure to follow installation instructions and not using the provided hardware may damage the intake tube, throttle body and engine.

## 1. Preparing Vehicle

- a. Make sure vehicle is parked on level surface.
- b. Set parking brake.
- c. If engine has run in the past two hours, let it cool down.
- d. Disconnect negative battery terminal.
- e. Do not discard stock components after removal of the factory system.

## 2. Removal of stock system



a. Factory airbox system installed.



b. Remove the engine cover by pulling straight up.

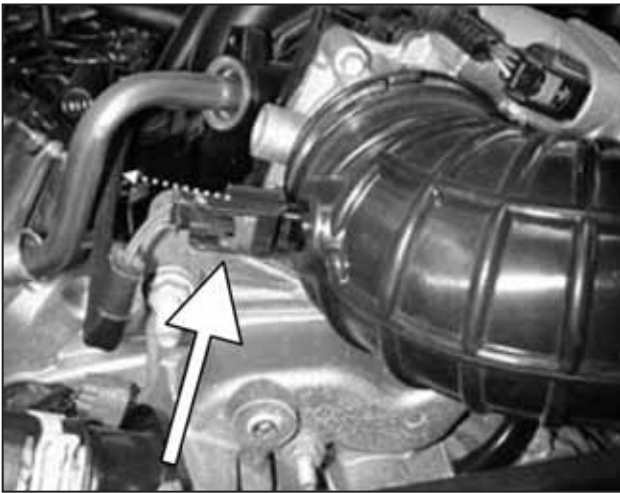

c. Pull out the locking clip for the intake air temperature (IAT) sensor.



d. With the locking clip out, disconnect the IAT sensor wire harness from the sensor. Leave the IAT sensor in place.

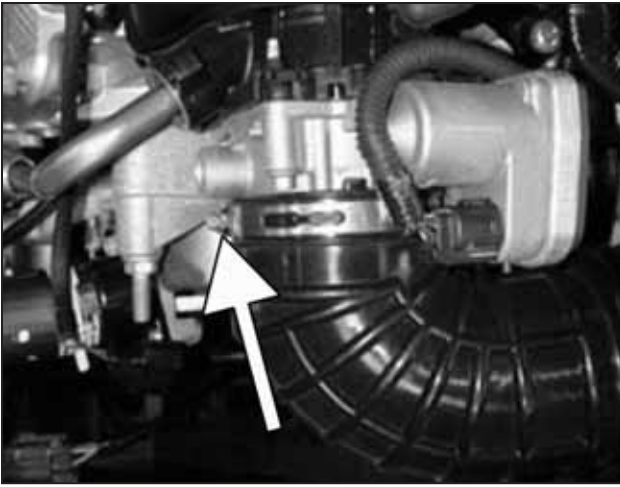

e. Loosen the inlet tube's hose clamp at the throttle body.

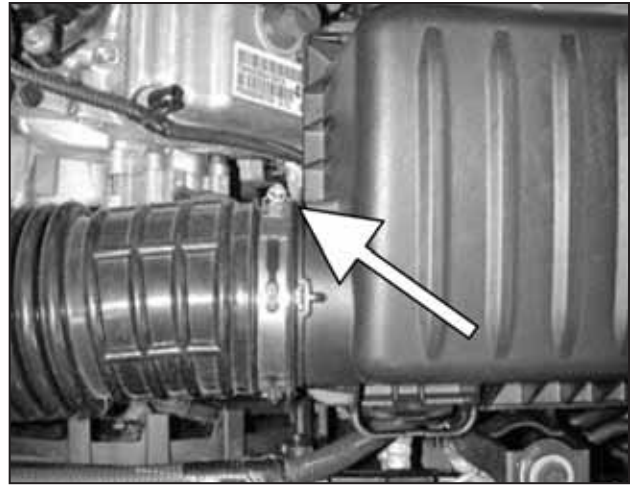

f. Loosen the the inlet tube hose clamp and remove the tube from the vehicle.

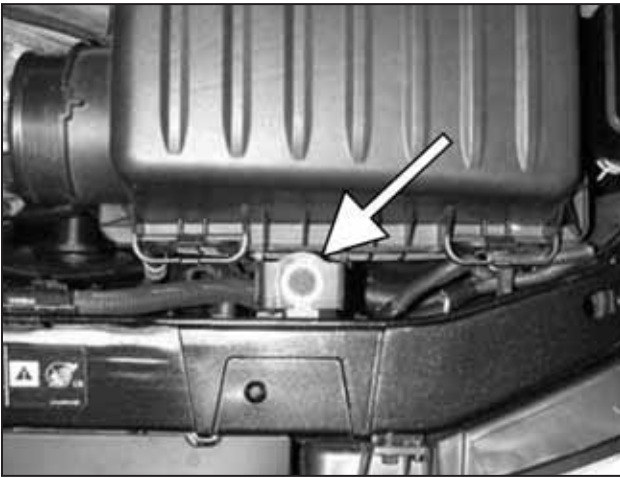

g. Loosen and remove the mounting bolt. This bolt will be reused in a later step. Remove the airbox.

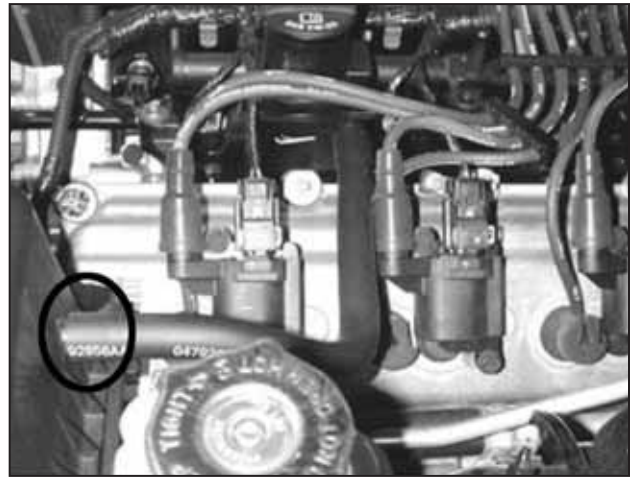

h. Remove valve cover breather hose from the airbox.

### 3. Installation of AEM® intake system.

a. When installing the intake system, do not completely tighten the hose clamps or mounting hardware until instructed to do so.



b. Attach the 2" long coupler onto the throttle body with the provided hose clamps. Tighten the throttle body side hose clamp.



c. Insert the heat shield. You will need to check all mounting surfaces in the following steps.



d. As you insert the heat shield into the engine bay, ensure the heat shield's tab slides securely into the slot as shown.

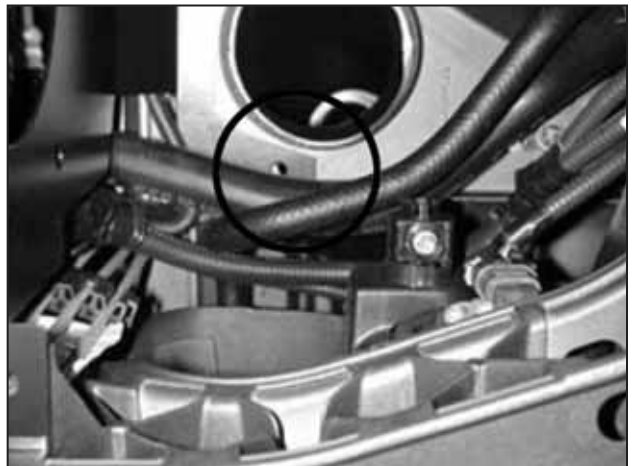

e. Check the clearance around the coolant lines. The mounting tab will pass under the coolant lines. Check for clearance against the wiring harness.



f. Check the final tab alignment. Insert the factory bolt removed in step 2g to secure this tab.

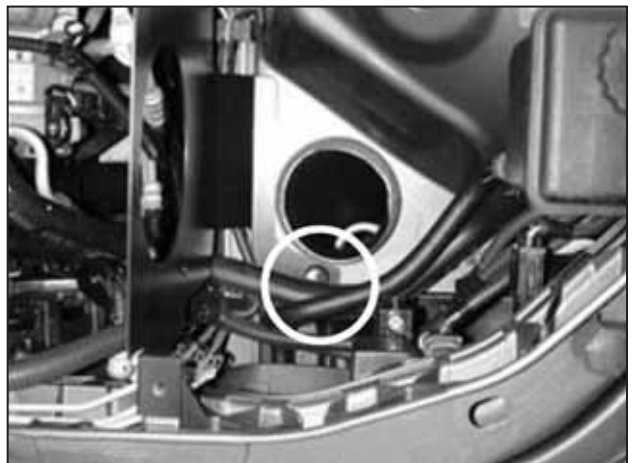

g. Insert the push in tab to secure the bottom mount.

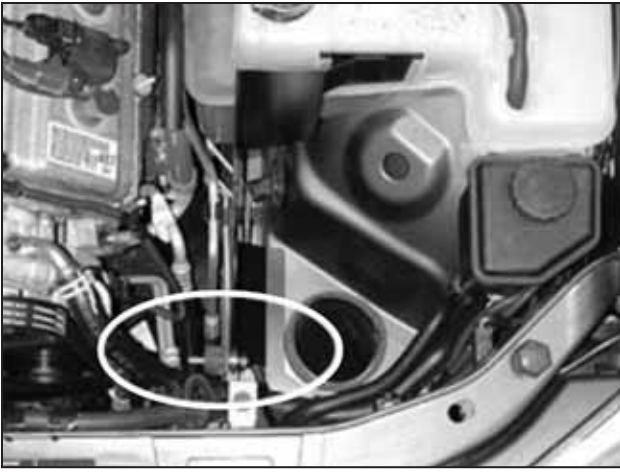

h. Insert the rubber mount into the heat shield and secure the supplied washer and nut.

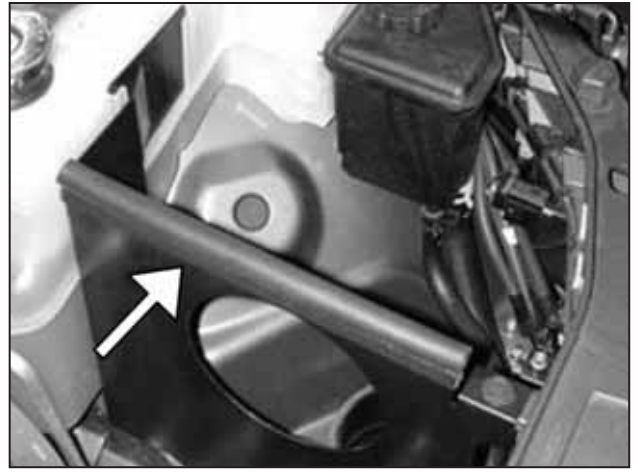

i. Attach the edge trim as shown.

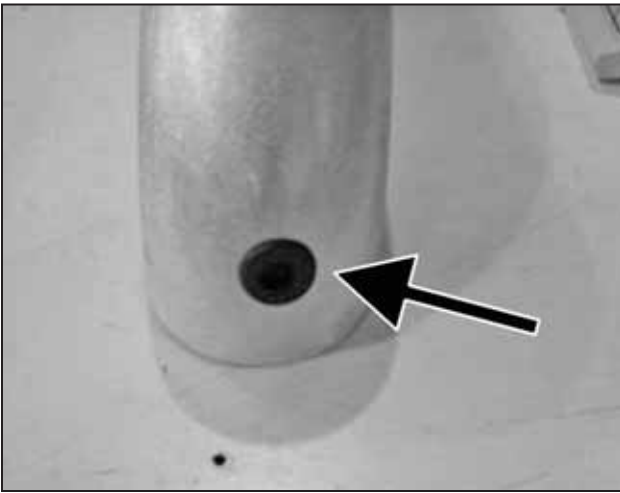

j. Insert the rubber grommet into the intake pipe.

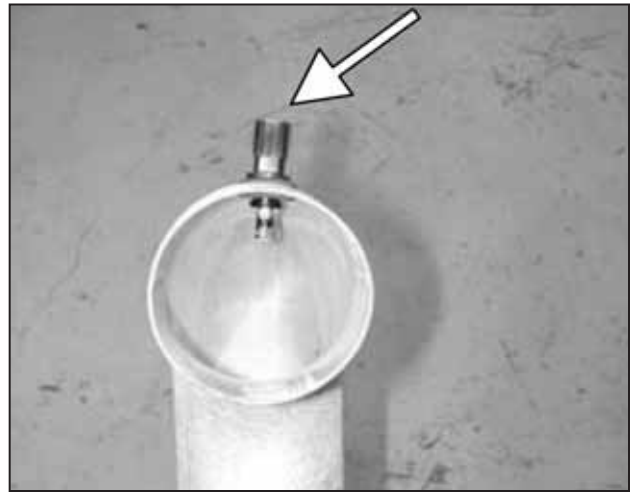

k. Insert the IAT sensor into the grommet. Use care when handling the sensor so it is not damaged.

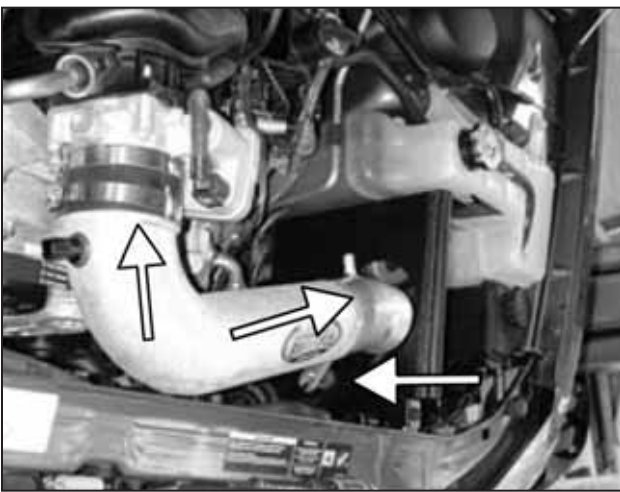

l. Insert the intake pipe into the heat shield opening. Then insert the intake pipe into the throttle body coupler. Align the intake pipe's mounting bracket with the rubber mount installed on the heat shield.



m. Attach the air filter element and tighten the hose clamp.

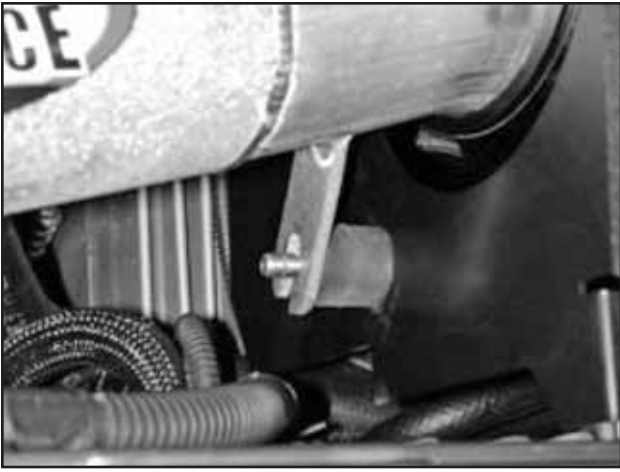

n. Align the bracket with the rubber mount. Once properly positioned, tighten the hose clamp securing the pipe to the throttle body.

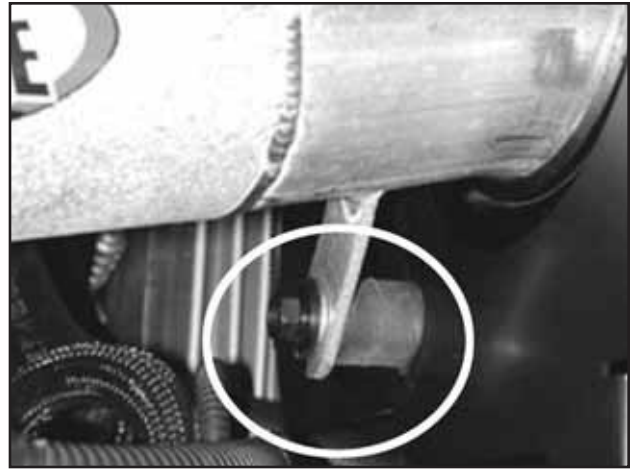

o. Secure the intake pipe to the rubber mount with a washer and nut. Refer to the diagram below for proper rubber mount installation.

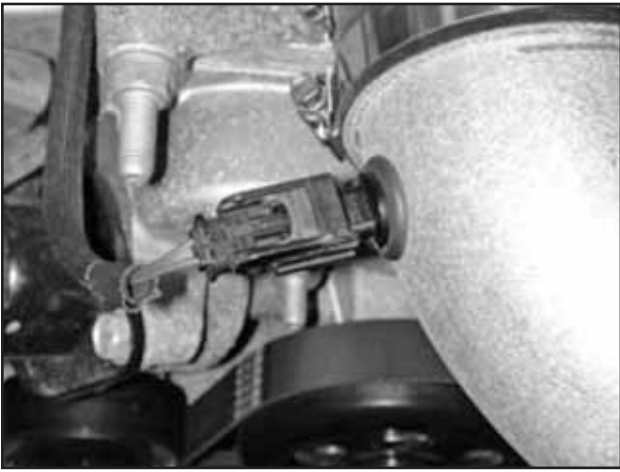

p. Reattach the IAT sensor wire harness and secure.

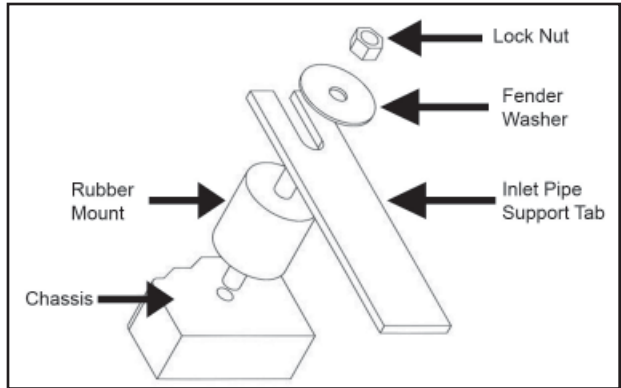

q. Diagram of proper rubber mount installation.



r. Insert the supplied plastic connector into the supplied breather hose.



s. Insert the other end of the plastic connector into the factory crankcase breather hose.

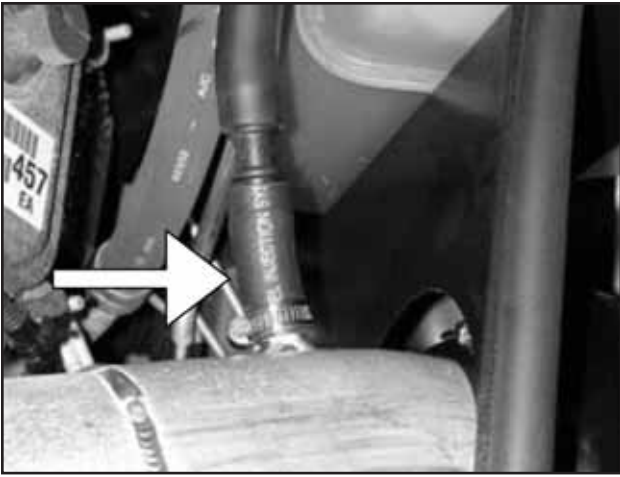

t. Attach the breather hose assembly to the intake pipe's nipple and secure with a hose clamp.



Factory air box system installed



AEM® intake system installed

#### 4. Reassemble Vehicle

- Position the inlet pipes for the best fitment. Be sure that the pipes or any other components do not contact any part of the vehicle. Tighten the rubber mount, all bolts, and hose clamps.
- Check for proper hood clearance. Re-adjust pipes if necessary and re-tighten them.
- Inspect the engine bay for any loose tools and check that all fasteners that were moved or removed are properly tightened.
- Reconnect negative battery terminals and start engine. Let the vehicle idle for 3 minutes. Perform a final inspection before driving the vehicle.

#### 5. CARB Sticker Placement

- The C.A.R.B. exemption sticker, (attached), must be visible under the hood so that an emissions inspector can see it when the vehicle is required to be tested for emissions. California requires testing every two years, other states may vary.

#### 6. Service and Maintenance

- It is recommended that you service your AEM® Dryflow™ filter every 20,000 miles for optimum performance. Use AEM Dryflow cleaning kit part # 21-110.
- Use aluminum polish to clean your polished AEM® intake tube.
- Use window cleaner to clean your powder coated AEM® intake tube. **(NOTE: DO NOT USE aluminum polish on powder coated AEM intake tubes).**

For technical inquiries  
e-mail us at  
sales@aemintakes.com  
or  
call us at  
800.992.3000

### **AEM Air Intake System Warranty Policy**

AEM® warrants that its intake systems will last for the life of your vehicle. AEM will not honor this warranty due to mechanical damage (i.e. improper installation or fitment), damage from misuse, accidents or flying debris. AEM will not warrant its powder coating if the finish has been cleaned with a hydrocarbon-based solvent. The powder coating should only be cleaned with a mild soap and water solution. Proof of purchase of both the vehicle and AEM intake system is required for redemption of a warranty claim.

This warranty is limited to the repair or replacement of the AEM part. In no event shall this warranty exceed the original purchase price of the AEM part nor shall AEM be responsible for special, incidental or consequential damages or cost incurred due to the failure of this product. Warranty claims to AEM must be transportation prepaid and accompanied with dated proof of purchase. This warranty applies only to the original purchaser of product and is nontransferable. Improper use or installation, use for racing, accident, abuse, unauthorized repairs or alterations voids this warranty. AEM disclaims any liability for consequential damages due to breach of any written or implied warranty on all products manufactured by AEM. Warranty returns will only be accepted by AEM when accompanied by a valid Return Merchandise Authorization (RMA) number. Credit for defective products will be issued pending inspection. Product must be received by AEM within 30 days of the date RMA is issued.

If you have a warranty issue, please call (800) 992-3000 and our customer service department will assist you. A proof of purchase is required for all AEM warranty claims.