



Equipped with AEM® Dryflow™ Filter
No Oil Required!

INSTALLATION INSTRUCTIONS

PART NUMBER: 21-642

2009-2011	MAZDA	Mazdaspeed	3	L4-2.3L	SEE * NOTE
2007-2008	MAZDA	Mazdaspeed	3	L4-2.3L	C.A.R.B. E.O. # D-670

* **NOTE** Legal in California only for racing vehicles which may never be used upon a highway

PARTS LIST

Description	Qty.	Part Number
A Air Filter Assy. 2.75 X 9" Dry Ele.	1	21-2029DK
B Upper Pipe	1	2-745
C Lower Pipe	1	2-746
D Hose, Adapter 2.5/2.75 45 Deg.	1	5-274
E Hose, Silicone 2.75x2" Black	1	5-272
F Mount, Rubber 1" X 6mm	1	1228599
G Venturi, MAF Insert	1	9-21070
H Bracket, MS3 Resistor Ballast	1	7-7854
I Bolt, Socket 8-32 X 5/16 SS	2	1-2023
J Bolt, Hex M6-1 X 12mm	3	1-2065
K Washer, M6 X 12mm OD Zinc	3	1-3018
L Washer, 6mm Soft Mount	1	08160
M Nut, M6 Hex Serrated	2	444.460.04
N 1/2" Bnd. Hose Clamp, 2.15-3.00"	1	9440
O 1/2" Bnd. Hose Clamp, 2.31-3.25"	3	9444
P 1/2" Bnd. Hose Clamp, 2.56"-3.50"	1	9448

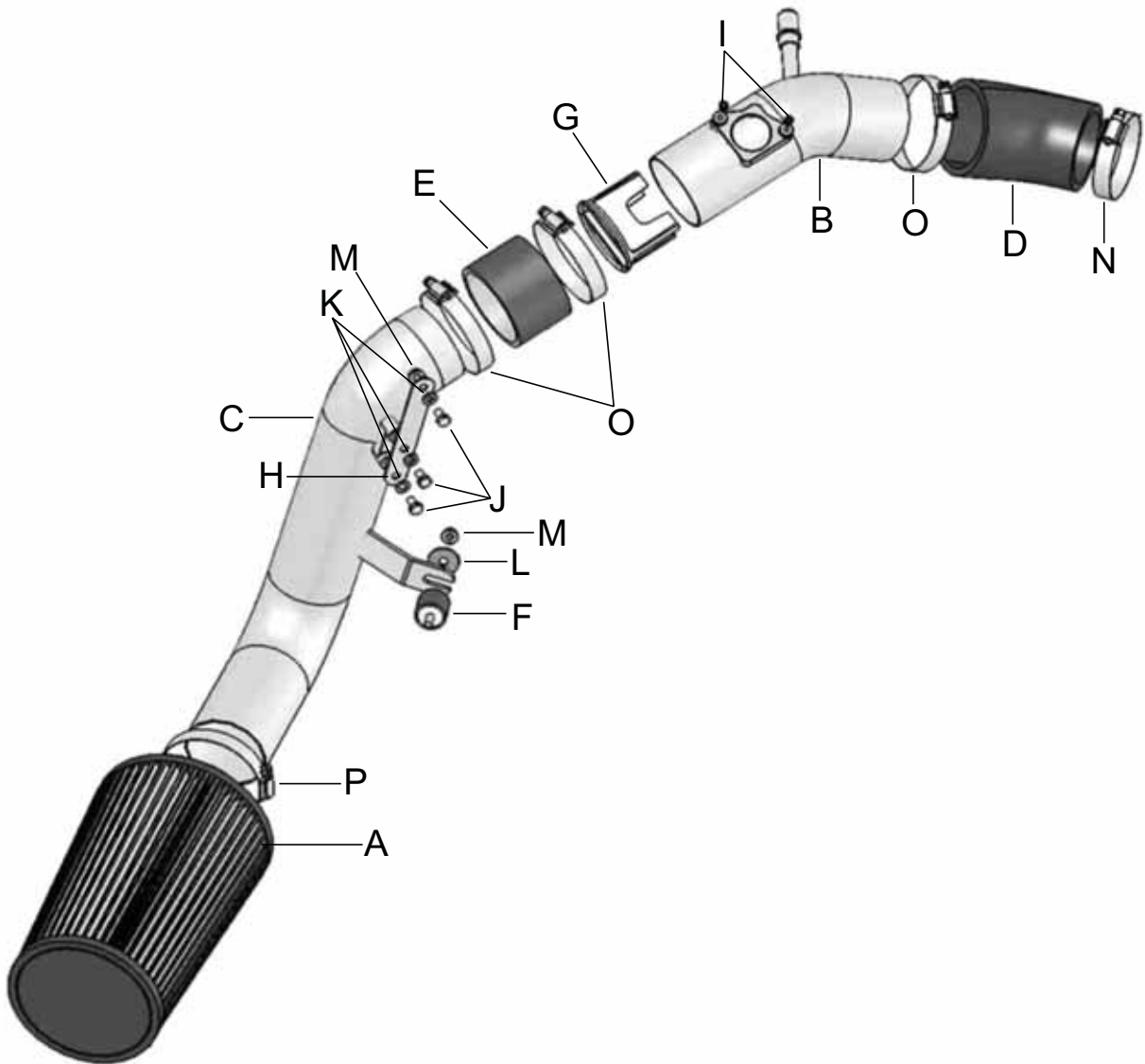

Read and understand these instructions **BEFORE** attempting to install this product. Failure to follow installation instructions and not using the provided hardware may damage the intake tube, throttle body and engine.

The AEM® intake system is a performance product that can be used safely during mild weather conditions. During harsh and inclement weather conditions, you must return your vehicle to stock OEM airbox and intake tract configuration. Failure to follow these instructions will void your warranty.

1. Preparing Vehicle

- a. Make sure vehicle is parked on level surface.
- b. Set parking brake.
- c. If engine has run in the past two hours, let it cool down.
- d. Disconnect negative battery terminal.
- e. Raise the front of the vehicle with a jack. Refer to your owner's manual for proper jack and jack stand placement to properly support vehicle. Support your vehicle using properly rated jack stands before wheel removal or while working under the vehicle.

NEVER WORK UNDER A VEHICLE WITHOUT USING JACK STANDS.

- f. Do not discard stock components after removal of the factory system.

2. Removal of stock system



a. Stock airbox system.



b. Remove the two bolts securing the plastic intercooler shroud. Remove the shroud.



c. Unplug and remove the mass air flow sensor (MAF) wiring harness.



d. Unclip the two metal retaining straps securing the air filter housing lid to the lower airbox housing. Loosen the hose clamp securing the inlet tube to the turbo inlet pipe and remove the lid.



e. Remove the air filter from the housing. Remove the rubber strap securing the front of the lower housing by pulling up on the loop.



f. Remove the check tab on the backside of the air filter housing, then slide the rubber isolator rearward. Lift up on the lower air filter housing and remove.



g. Disconnect the plastic breather hose from the inlet tube by squeezing the blue retaining clip and pulling on the breather hose. Loosen the hose clamp on the turbo inlet and remove the tube.



h. From underneath the vehicle remove the seven bolts and two plastic connectors securing the center splash shield in place, then remove the center splash shield.



i. Remove the driver side wheel. Remove the two bolts and plastic screw securing the inner-wheel splash shield. Remove the splash shield from the vehicle.



j. Remove the three bolts and the two plastic screw connectors securing the inner fender liner. Position the fender liner out of the way so the inner bumper/fender area can be accessed.

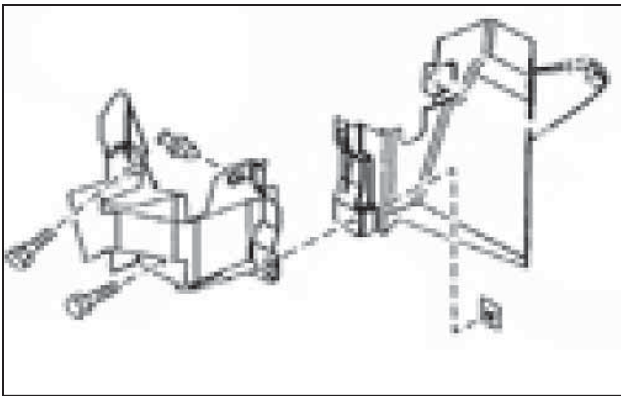

k. Remove the bolt, attachment clip, and plastic screw connector for the air director located behind the left fog lamp/headlamp housing. Remove the air director.

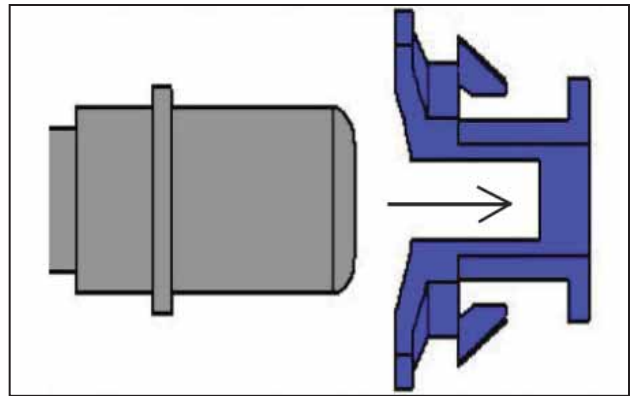

l. Obtain the inlet tube that was previously removed, remove the blue plastic breather hose clip from the breather nipple by carefully prying up on the two small tabs on both sides of the clip.

3. Installation of AEM® intake system.

a. When installing the intake system, do not completely tighten the hose clamps or mounting hardware until instructed to do so.



b. Install the 45-degree coupler onto the turbo inlet and secure using a #40 hose clamp.



c. Install the plastic breather hose clip (removed in step 2l) onto the nipple of the upper intake pipe. Simply slide the clip over the end until it snaps into place.



d. Install the MAF sensor into the upper intake pipe with the provided 8-32 bolts. Install the 2.75" straight coupler onto the intake pipe end closest to the MAF sensor.



e. Slide the airflow straightener through the coupler and into intake pipe, aligning the slots with the MAF sensor as shown.



f. Install the upper intake pipe into the 45-degree coupler on the turbo inlet. Rotate the intake pipe until the breather hose aligns with the intake pipe's nipple. Attach the breather hose to the intake pipe nipple and connect the MAF sensor harness connector to the MAF sensor.



g. Locate the resistor ballast for the headlight on the inside of the driver's side frame rail. Unplug the wiring harness and remove the two bolts securing it in place.



h. Thread the supplied rubber mount into the hole where the resistor ballast was previously mounted.



i. Attach the resistor ballast to the lower intake pipe using the mounting bracket, three M6 bolts, three washers, and one M6 nut.



j. Install the lower intake pipe into the coupler of the upper intake pipe, and secure in place with a #44 hose clamp. Align the intake mounting bracket with the rubber mount that was installed in the step 3h.



k. Secure the lower intake pipe's mounting bracket to the rubber mount with a M6 washer and nut. Reconnect the wiring harness to the resistor ballast.



l. Install the air filter onto the end of the lower intake pipe. Push the air filter over the intake pipe until the stop in the air filter is reached. Secure the air filter onto the intake pipe with a #48 hose clamp.



m. Reinstall the intercooler cover and check for clearance. Adjust the intake pipes if necessary.



Factory airbox system installed



AEM® intake system installed

4. Reassemble Vehicle

- a. **Center Splash Shield:** Install and secure the splash shield removed in step 2h.
- b. **Fender liner:** Install the fender liner and any hardware that was removed during
NOTE: Failure to install the fender liner will result in diminished performance and increase the potential for engine damage due to water ingestion in rainy conditions.
- c. **Wheel:** Install the driver's side wheel using the factory torque specification (see owner's manual).
- d. Position the inlet pipes for the best fitment. Be sure that the pipes or any other components do not contact any part of the vehicle. Tighten the rubber mount, all bolts, and hose clamps.
- e. Check for proper hood clearance. Re-adjust pipes if necessary and re-tighten them.
- f. Inspect the engine bay for any loose tools and check that all fasteners that were moved or removed are properly tightened.
- g. Reconnect negative battery terminals and start engine. Let the vehicle idle for 3 minutes. Perform a final inspection before driving the vehicle.

5. CARB Sticker Placement

- a. The C.A.R.B. exemption sticker, (attached), must be visible under the hood so that an emissions inspector can see it when the vehicle is required to be tested for emissions. California requires testing every two years, other states may vary.

6. Service and Maintenance

- a. It is recommended that you service your AEM® Dryflow™ filter every 20,000 miles for optimum performance. Use AEM Dryflow cleaning kit part # 21-110.
- b. Use aluminum polish to clean your polished AEM® intake tube.
- c. Use window cleaner to clean your powder coated AEM® intake tube. **(NOTE: DO NOT USE aluminum polish on powder coated AEM intake tubes)**

For technical inquiries
e-mail us at
sales@aemintakes.com
or
call us at
800.992.3000

AEM Air Intake System Warranty Policy

AEM® warrants that its intake systems will last for the life of your vehicle. AEM will not honor this warranty due to mechanical damage (i.e. improper installation or fitment), damage from misuse, accidents or flying debris. AEM will not warrant its powder coating if the finish has been cleaned with a hydrocarbon-based solvent. The powder coating should only be cleaned with a mild soap and water solution. Proof of purchase of both the vehicle and AEM intake system is required for redemption of a warranty claim.

This warranty is limited to the repair or replacement of the AEM part. In no event shall this warranty exceed the original purchase price of the AEM part nor shall AEM be responsible for special, incidental or consequential damages or cost incurred due to the failure of this product. Warranty claims to AEM must be transportation prepaid and accompanied with dated proof of purchase. This warranty applies only to the original purchaser of product and is nontransferable. Improper use or installation, use for racing, accident, abuse, unauthorized repairs or alterations voids this warranty. AEM disclaims any liability for consequential damages due to breach of any written or implied warranty on all products manufactured by AEM. Warranty returns will only be accepted by AEM when accompanied by a valid Return Merchandise Authorization (RMA) number. Credit for defective products will be issued pending inspection. Product must be received by AEM within 30 days of the date RMA is issued.

If you have a warranty issue, please call (800) 992-3000 and our customer service department will assist you. A proof of purchase is required for all AEM warranty claims.