



Equipped with AEM® Dryflow™ Filter  
No Oil Required!

# INSTALLATION INSTRUCTIONS

## PART NUMBER:21-631

---

2000-2002 SATURN SC2 L4-1.9L

C.A.R.B. E.O. # D-670

**\* NOTE: Legal in California only for racing vehicles which may never be used upon a highway**

## PARTS LIST

Description	Qty.	Part Number
Air Filter Assy. 2.25 X 5" Dry Ele.	1	21-200DK
Upper Pipe	1	2-521
Lower Pipe	1	2-522
Hose, Silicone 2.25x3" Blk.	2	5-225
Hose; 3/8"ID X 18"L	1	5-1018
Mount, Rubber 1" X 6mm	1	1228599
Grommet, 3/8"	1	784633
Washer, 6mm Soft Mount	1	559999
Nut, M6 Hex Serrated	1	444.460.04
1/2' Bnd. Hose Clamp, 2.15-3.00"	1	9440
Hose Clamp, 2.25	4	103-BLO-3620
Hose Clamp, 3/4"	2	4093-5

Read and understand these instructions **BEFORE** attempting to install this product. Failure to follow installation instructions and not using the provided hardware may damage the intake tube, throttle body and engine.

The AEM® intake system is a performance product that can be used safely during mild weather conditions. During harsh and inclement weather conditions, you must return your vehicle to stock OEM air box and intake tract configuration. Failure to follow these instructions will void your warranty.

## 1. Preparing Vehicle

- a. Make sure vehicle is parked on level surface.
- b. Set parking brake.
- c. If engine has run in the past two hours, let it cool down.
- d. Disconnect negative battery terminal.
- e. Do not discard stock components after removal of the factory system.

## 2. Removal of stock system



a. Loosen the hose clamps and disconnect the crankcase breather hose. Remove intake tubing.



b. Remove the plastic clip from the resonator. Remove the resonator from the vehicle.

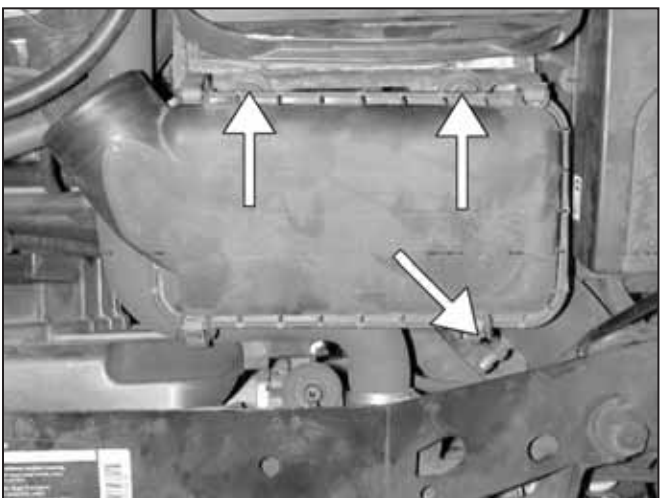

c. Remove the 3 - 10mm bolts securing the air box in place.



d. Unplug the IAT from the factory air box. Remove the air box from the vehicle.

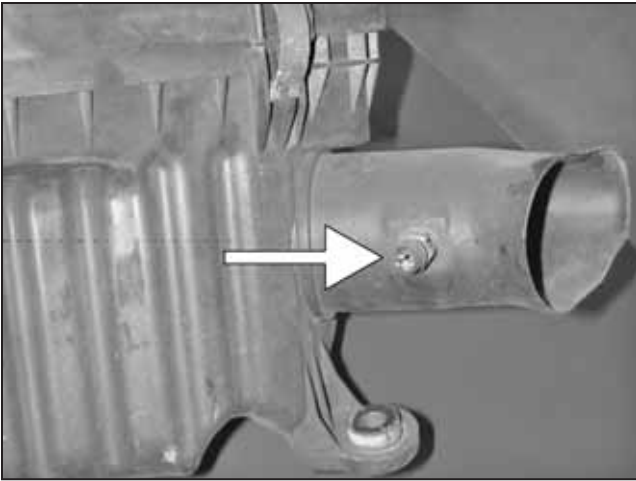

e. Remove the IAT from the air box.

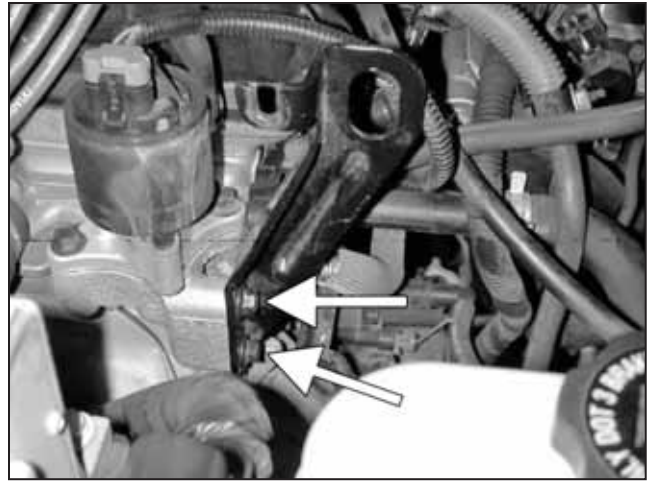

f. Remove the inlet tube bracket by removing the bolts as shown.

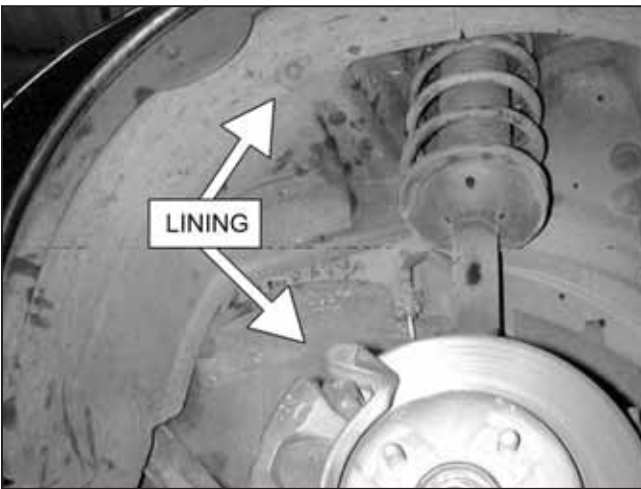

g. Remove the clips that secure the fender liners to the wheel well.

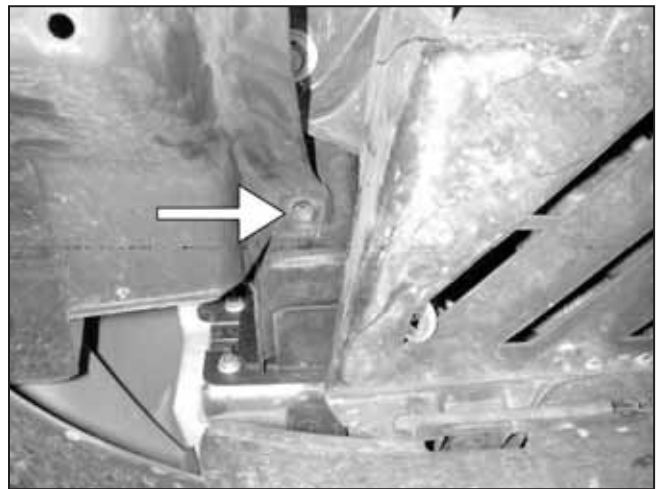

h. Remove the hidden clip, then pull back the fender lining.

### 3. Installation of AEM® intake system.

a. When installing the intake system, do not completely tighten the hose clamps or mounting hardware until instructed to do so.

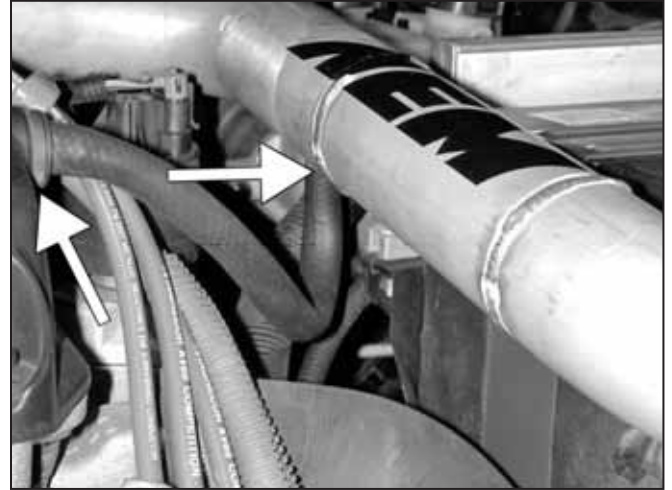

b. Attach the upper intake pipe with the provided couplers and hose clamps.

c. Attach the crankcase breather hose to the valve cover and the intake pipe.

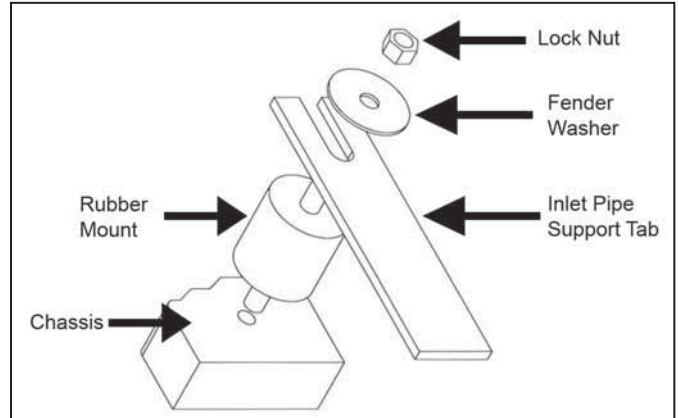
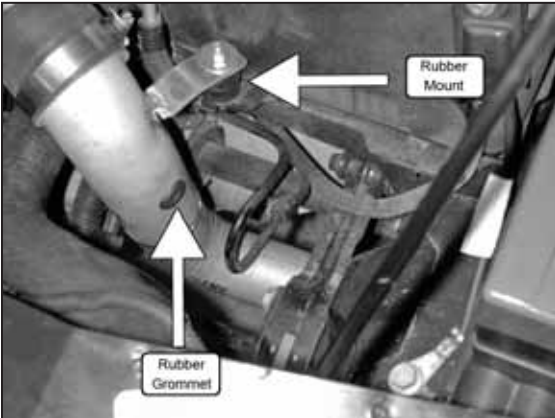

d. Insert the rubber mount in the location depicted in the image above. Install the grommet into the lower intake pipe as shown. Install the lower intake pipe by inserting the pipe up into the engine bay from the fender well area. Insert the intake pipe into the coupler while also aligning the bracket onto the rubber mount stud. Secure but do not completely tighten the hose clamp on the coupler. Also secure the fender washer and nut onto the rubber mount assembly, but do not completely tighten. Install the IAT into the rubber grommet that was previously installed on the lower intake pipe. Connect the IAT wire harness to the sensor.

Proper installation of the rubber mount assembly.



e. Install the air filter onto the intake pipe and secure with the provided hose clamp. Adjust the air filter for best fitment and ensure sufficient clearance.



f. Attach the inner fender liner to determine where it will make contact with the intake pipe. The inner fender liner will need to be trimmed to clear the intake pipe. Once the liner is trimmed and provides adequate clearance, install the liner and the hardware needed to secure it in place.

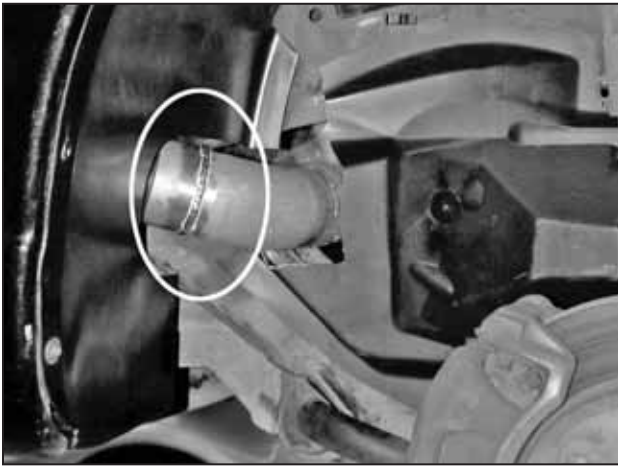

g. Attach the outer fender liner to determine where it will make contact with the intake pipe. The outer fender liner will need to be trimmed to clear the intake pipe. Once the liner is trimmed and provides adequate clearance, install the liner and the hardware needed to secure it in place.

#### 4. Reassemble Vehicle

- a. Position the inlet pipes for the best fitment. Be sure that the pipes or any other components do not contact any part of the vehicle. Tighten the rubber mount, all bolts, and hose clamps.
- b. Check for proper hood clearance. Re-adjust pipes if necessary and re-tighten them.
- c. Inspect the engine bay for any loose tools and check that all fasteners that were moved or removed are properly tightened.
- d. Reconnect negative battery terminals and start engine. Let the vehicle idle for 3 minutes. Perform a final inspection before driving the vehicle.

#### 5. CARB Sticker Placement

- a. The C.A.R.B. exemption sticker, (attached), must be visible under the hood so that an emissions inspector can see it when the vehicle is required to be tested for emissions. California requires testing every two years, other state may vary.

#### 6. Service and Maintenance

- a. It is recommended that you service your AEM® Dryflow™ filter every 20,000 miles for optimum performance. Use AEM Dryflow cleaning kit part # 21-110.
- b. Use aluminum polish to clean your polished AEM® intake tube.
- c. Use window cleaner to clean your powder coated AEM® intake tube. **(NOTE: DO NOT USE aluminum polish on powder coated AEM intake tubes).**

For technical inquiries  
e-mail us at  
sales@aemintakes.com  
or  
call us at  
800.992.3000

#### AEM Air Intake System Warranty Policy

AEM® warrants that its intake systems will last for the life of your vehicle. AEM will not honor this warranty due to mechanical damage (i.e. improper installation or fitment), damage from misuse, accidents or flying debris. AEM will not warrant its powder coating if the finish has been cleaned with a hydrocarbon-based solvent. The powder coating should only be cleaned with a mild soap and water solution. Proof of purchase of both the vehicle and AEM intake system is required for redemption of a warranty claim.

This warranty is limited to the repair or replacement of the AEM part. In no event shall this warranty exceed the original purchase price of the AEM part nor shall AEM be responsible for special, incidental or consequential damages or cost incurred due to the failure of this product. Warranty claims to AEM must be transportation prepaid and accompanied with dated proof of purchase. This warranty applies only to the original purchaser of product and is nontransferable. Improper use or installation, use for racing, accident, abuse, unauthorized repairs or alterations voids this warranty. AEM disclaims any liability for consequential damages due to breach of any written or implied warranty on all products manufactured by AEM. Warranty returns will only be accepted by AEM when accompanied by a valid Return Merchandise Authorization (RMA) number. Credit for defective products will be issued pending inspection. Product must be received by AEM within 30 days of the date RMA is issued.

If you have a warranty issue, please call (800) 992-3000 and our customer service department will assist you. A proof of purchase is required for all AEM warranty claims.