

INSTALLATION INSTRUCTIONS

77-9032

TOYOTA
2007 - 08 Tundra
2008 Sequoia
V8- 4.7L

Note: This kit was not designed to fit vehicles with a body lift.

TOOLS:

- Ratchet
- Extension
- 10mm Socket
- Flat Blade Screwdriver
- Phillips Screwdriver
- 9/16" Wrench
- 5/8" Wrench
- Pliers

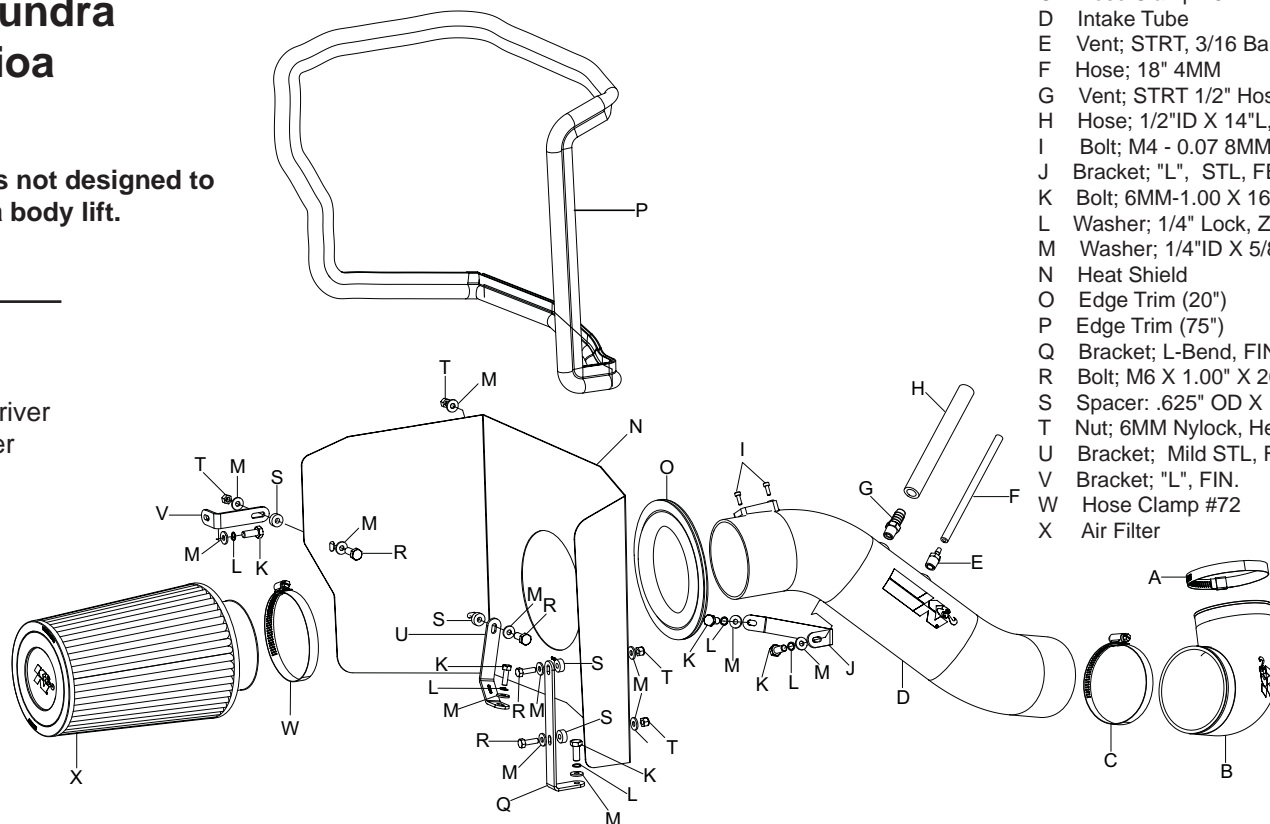

PARTS LIST:

| Desc. | Qty. | Part # |
|---|------|---------|
| A Hose Clamp #56 | 1 | 08620 |
| B Hose; 3-1/2" ID To 4" ID, Elbow, Black Silic. | 1 | 084086 |
| C Hose Clamp #64 | 1 | 08645 |
| D Intake Tube | 1 | 27184 |
| E Vent; STRT, 3/16 Barbed 1/4" NPT, Nylon | 1 | 080021 |
| F Hose; 18" 4MM | 1 | 08153 |
| G Vent; STRT 1/2" Hose, 1/4" NPT, Plastic | 1 | 080022 |
| H Hose; 1/2"ID X 14"L, Black Silicone | 1 | 08402 |
| I Bolt; M4 - 0.07 8MM, A/H Cap, SS | 2 | 07733 |
| J Bracket; "L", STL, FB/PC | 1 | 06492 |
| K Bolt; 6MM-1.00 X 16MM, SS | 5 | 07812 |
| L Washer; 1/4" Lock, ZN | 5 | 08198 |
| M Washer; 1/4"ID X 5/8"OD - SAE | 13 | 08275 |
| N Heat Shield | 1 | 07653 |
| O Edge Trim (20") | 1 | 102494 |
| P Edge Trim (75") | 1 | 102460 |
| Q Bracket; L-Bend, FIN | 1 | 070902 |
| R Bolt; M6 X 1.00" X 20MM Hex, SS | 4 | 07795 |
| S Spacer; .625" OD X .250"ID X .250"L, Alum. | 4 | 06555 |
| T Nut; 6MM Nylock, Hex Head, SS | 4 | 07512 |
| U Bracket; Mild STL, FB/PC | 1 | 07190 |
| V Bracket; "L", FIN. | 1 | 070742 |
| W Hose Clamp #72 | 1 | 08671 |
| X Air Filter | 1 | RU-5045 |

NOTE: FAILURE TO FOLLOW INSTALLATION INSTRUCTIONS AND NOT USING THE PROVIDED HARDWARE MAY DAMAGE THE INTAKE TUBE, THROTTLE BODY AND ENGINE.

TO START:

1. Turn off the ignition and disconnect the negative battery cable.

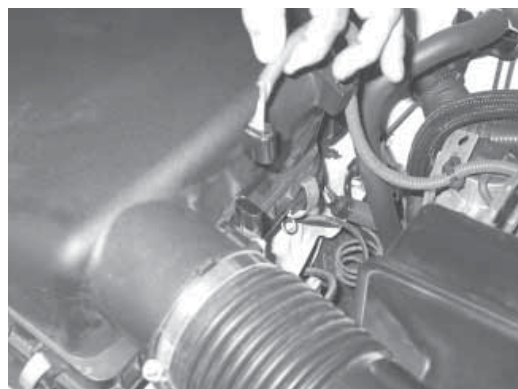

2. Disconnect the mass air sensor electrical connection. Then unclip the mass air sensor wiring harness from the air box.

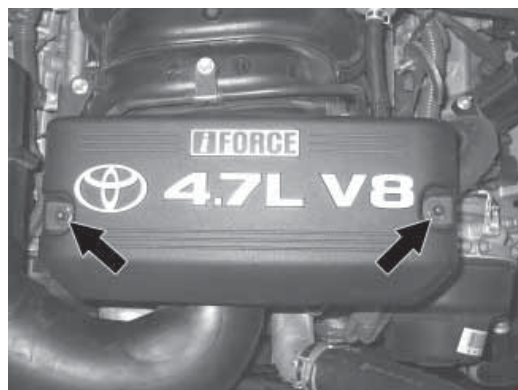

3. Remove the two nuts that retain the engine cover. Remove the engine cover from the engine.

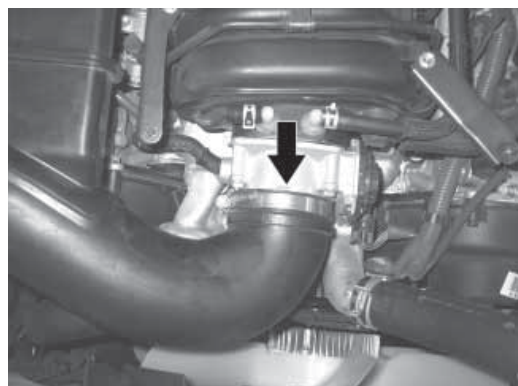

4. Loosen the hose clamp that secures the stock intake tube to the throttle body.

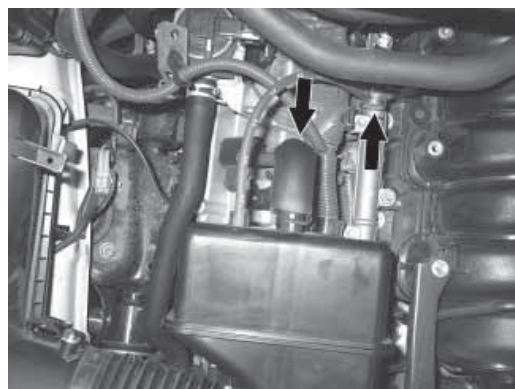

5. Disconnect the fuel pressure regulator hose from the fuel pressure regulator. Disconnect the crank case vent hose from the valve cover.



6. Release the four upper air box clam shell clamps, then remove the upper air box and intake tube assembly.

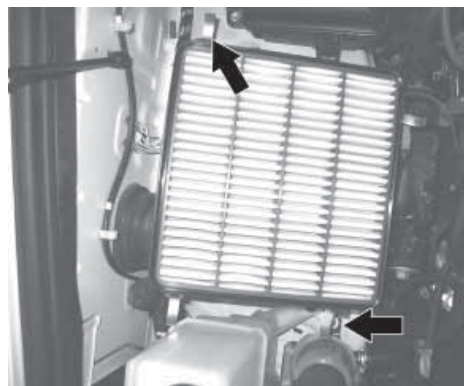

7. Remove the two factory bolts that secure the lower air box to the inner fender. **NOTE: K&N Engineering, Inc., recommends that customers do not discard factory air intake.**

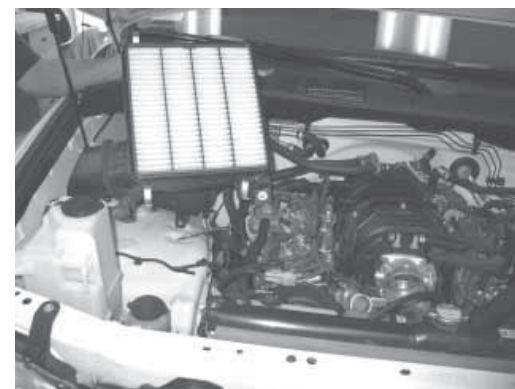

8. Lift the lower air box up, releasing it from the inner fender mounting grommet and fresh air duct. Remove the lower air box from the vehicle.

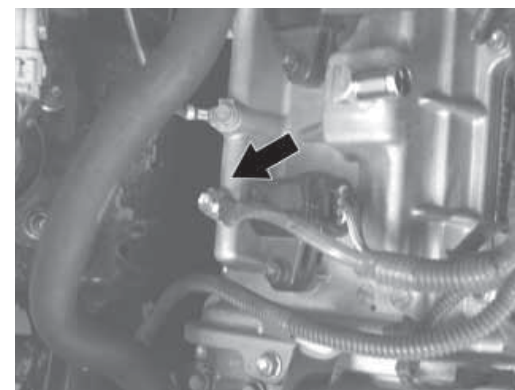

9. Remove the ground strap bolt on the engine valve cover as shown.

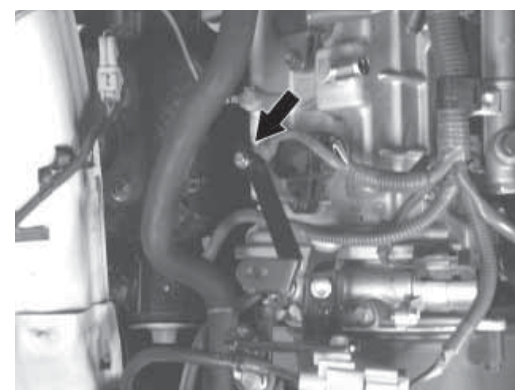

10. Install the tube mounting bracket onto the valve cover with the provided hardware.

NOTE: The ground strap is to be installed under the mounting bracket, in its original location.



11. Install the small "L" bracket (#070742) onto the inner fender, behind the hood support. Secure with the provided hardware as shown.



12. Install the long edge trim onto the heat shield as shown.

NOTE: Some trimming of the edge trim may be necessary.



13. Install the short edge trim into the hole in the heat shield as shown.

NOTE: Some trimming of the edge trim may be necessary.



14. Install the long "L" bracket (#070902) onto the heat shield with the provided hardware as shown.

NOTE: Place the two provided spacers between the bracket and heat shield, one on each bolt.

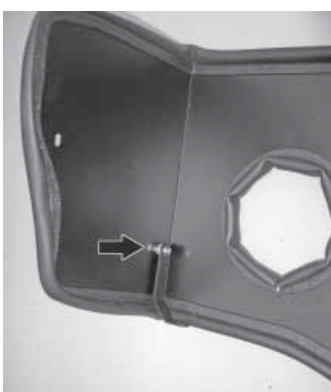

15. Install the provided "C" (#07190) bracket onto the heat shield with the provided hardware as shown.

NOTE: One of the provided spacers is to be placed between the bracket and heat shield.

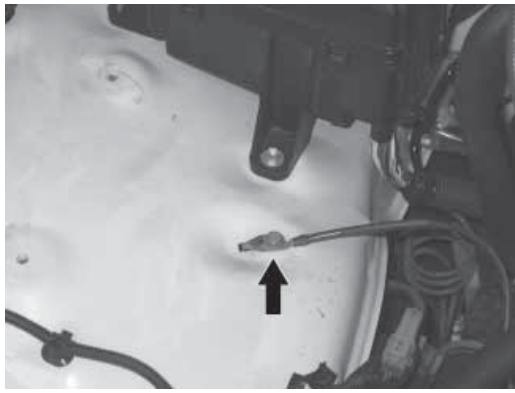

16. Remove the bolt that retains the ground strap to the inner fender.



17. Set the heat shield into position on the inner fender. Secure the "C" bracket to the ground strap location.

NOTE: The ground strap is to be installed in its original location under the heat shield bracket.



18. Secure the front heat shield bracket to the front air box mounting location with the provided hardware.



19. Secure the rear of the heat shield to the bracket installed in step #11.

NOTE: Place one of the supplied spacers between the heat shield and bracket.

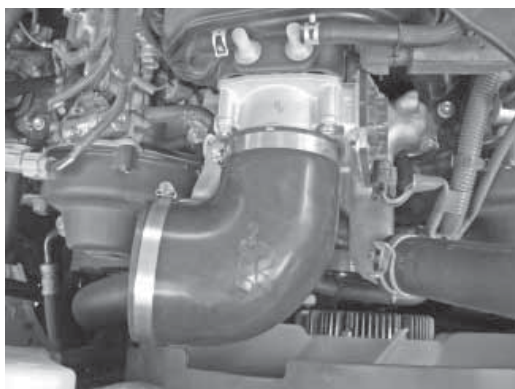

20. Install the silicone hose (#084086) onto the throttle body and secure with the provided hose clamp.

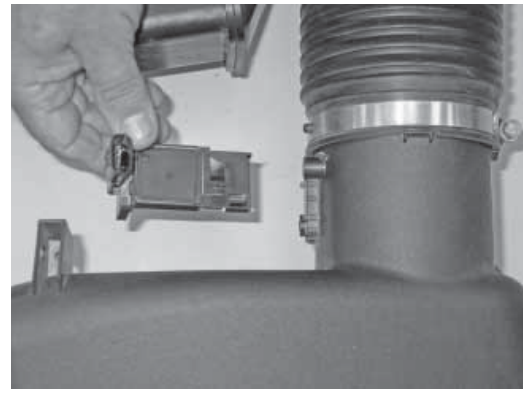

21. Remove the factory screws that secure the mass air sensor to the factory intake tube, and then remove the mass air sensor from the stock intake tube.

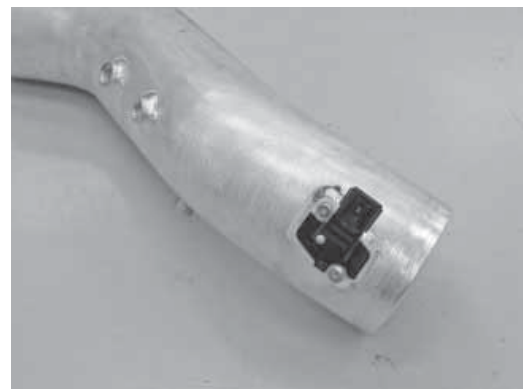

22. Install the mass air sensor into the K&N® intake tube and secure with the provided hardware.

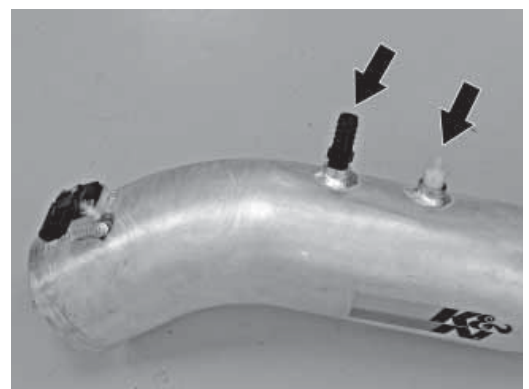

23. Install the provided 1/4"npt fittings into the K&N® intake tube as shown.

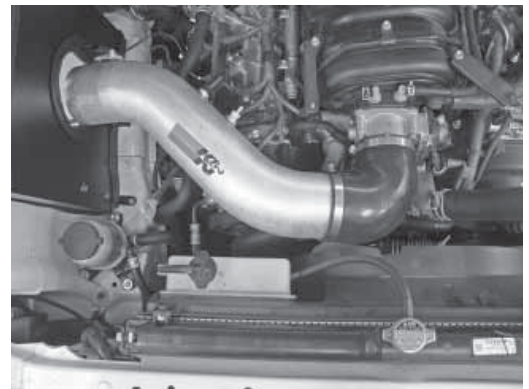

24. Install the K&N® intake tube into the silicone hose at the throttle body and align with the mounting bracket installed during step #10. Secure the intake tube with the hose clamp and hardware provided.

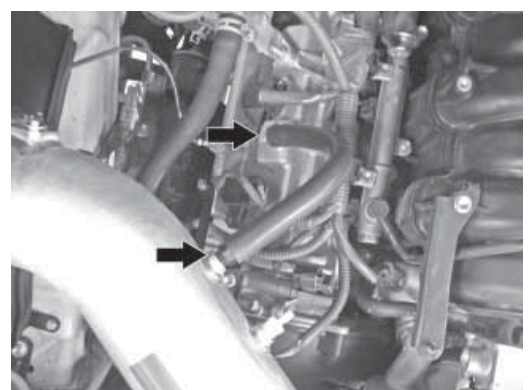

25. Install the provided crank case vent hose onto the valve cover fitting, and then connect the open end to the NPT fitting installed into the K&N® intake tube as shown.

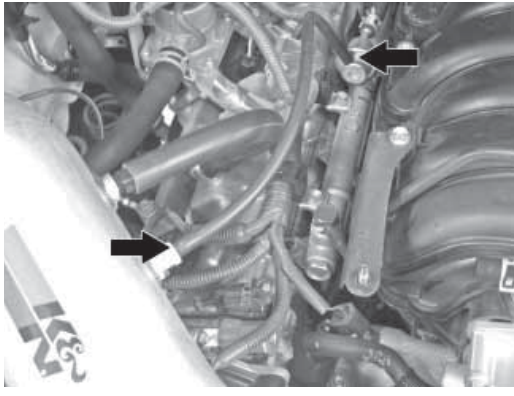

26. Install the provided fuel pressure hose onto the fuel pressure regulator and then connect the open end onto the remaining NPT fitting installed into the K&N® intake tube as shown.

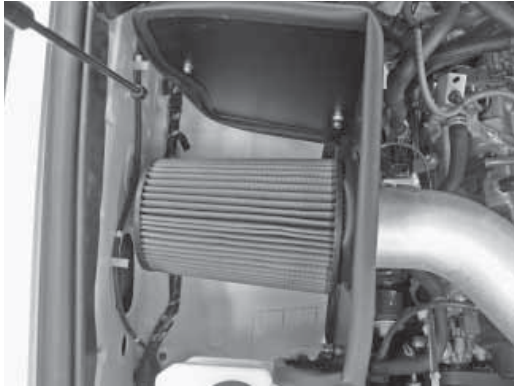

27. Install the K&N® air filter onto the K&N® intake tube and secure with the provided hose clamp.



28. Reconnect the mass air sensor electrical connection as shown.



29. Reinstall the engine cover and secure with the factory nuts.

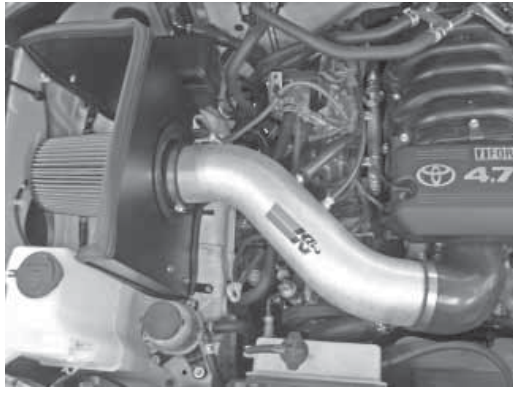

30. Reconnect the vehicles negative battery cable. Double check to ensure everything is tight and properly positioned before starting the vehicle.

31. It will be necessary for all K&N® high flow intake systems to be checked periodically for realignment, clearance and tightening of all connections. Failure to follow the above instructions or proper maintenance may void warranty.

ROAD TESTING:

1. Start the engine with the transmission in neutral or park, and the parking brake engaged. Listen for air leaks or odd noises. For air leaks secure hoses and connections. For odd noises, find cause and repair before proceeding. This kit will function identically to the factory system except for being louder and much more responsive.

2. Test drive the vehicle. Listen for odd noises or rattles and fix as necessary.

3. If road test is fine, you can now enjoy the added power and performance from your kit.

4. K&N Engineering, Inc., suggests checking the air filter element periodically for excessive dirt build-up. When the element becomes covered in dirt (or once a year), service it according to the instructions on the Recharger® service kit, part number 99-5000 or 99-5050.