



## INSTALLATION INSTRUCTIONS

### 77-9031-1

### TOYOTA

### 2007-10 Tundra

### 2008-10 Sequoia

### V8-5.7L

**NOTE:** This kit was not designed to fit vehicles with a body lift.

#### TOOLS NEEDED:

3mm allen wrench  
10mm socket  
10mm wrench  
extension  
ratchet  
flat blade screwdriver  
phillips screwdriver

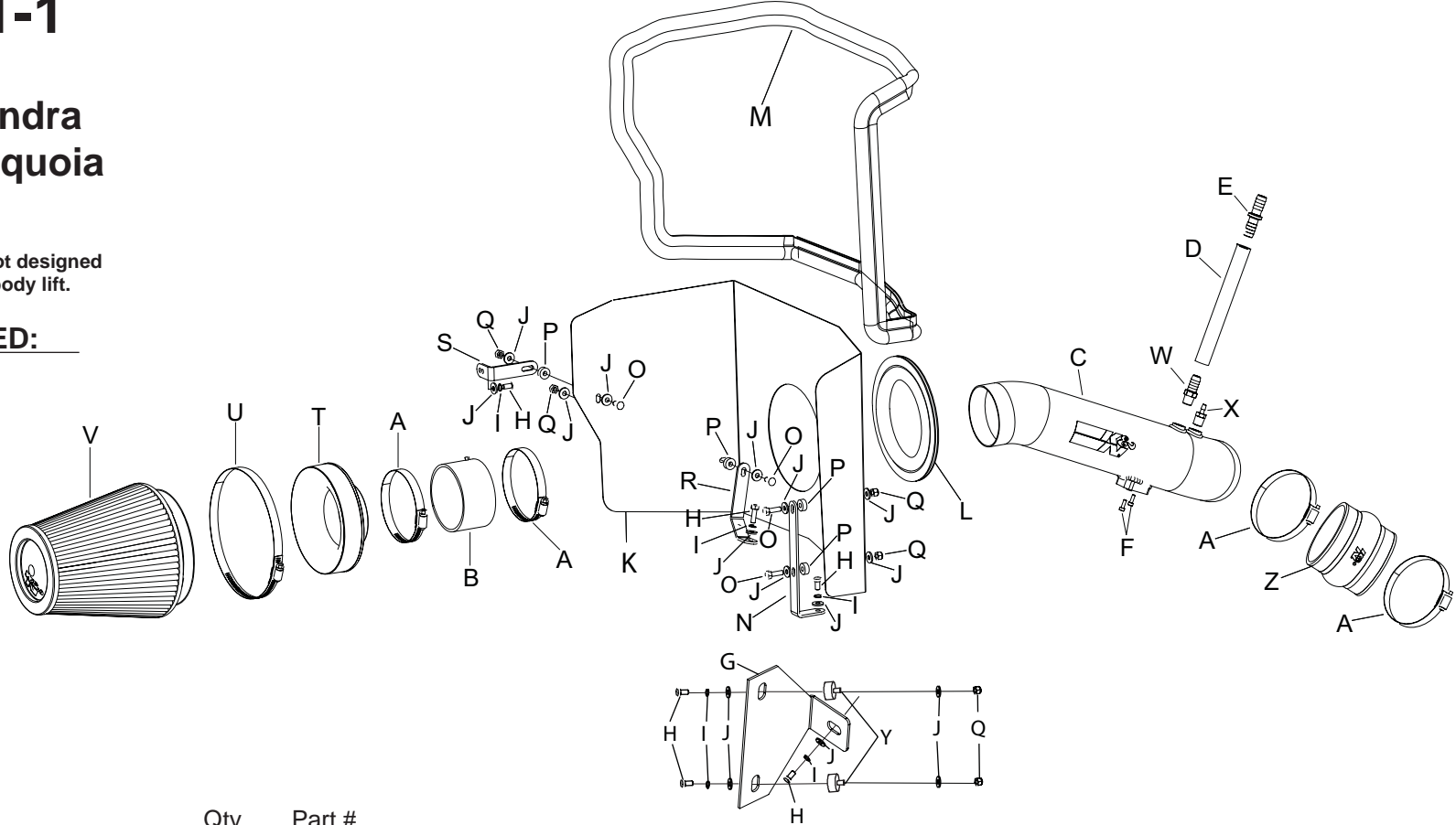

#### PARTS LIST:

Description	Qty.	Part #	Description	Qty.	Part #	Description	Qty.	Part #
A Hose Clamp #56	4	08620	J Washer; 1/4"ID X 5/8"OD - SAE	16	08275	S Bracket; "L"	1	070742
B Hose; 3.5"ID X 2"L, Black Silicone	1	08630	K Heat Shield	1	07653-1	T Adaptor; #380	1	21512
C Intake Tube	1	27530-2	L Edge Trim (20")	1	102494	U Hose Clamp #104	1	08697
D Hose; 1/2"ID X 7"L, Black Silicone	1	08159	M Edge Trim (75")	1	102460	V Air Filter	1	RF-1042
E Hose; Mender, 1/2" Barbed, Nylon	1	08686	N Bracket; L-Bend	1	070902	W Vent; Strt., 1/2" Hose, 1/4" NPT	1	080022
F Bolt; M4 - 0.07 8MM, A/H Cap, SS	2	07733	O Bolt; M6 X 1.00" X 20MM Hex, SS	4	07795	X Vent; Strt., 3/16 Barbed 1/4"NPT	1	080021
G Bracket; "L" STL, TK/PC	1	083128	P Spacer: .625" OD X .250"ID X .250"L, Alum.	4	06555	Y Stud; MNT, M/F, 1/2"LX1"W, M6X 1.00	2	070228
H Bolt; 6MM-1.00 X 16MM, SS	6	07812	Q Nut; 6MM Nylock, Hexhead, SS	6	07512	Z Hose; 3-1/2"ID X 3" L HUMP	1	084057
I Washer; 1/4" Lock, ZN	6	08198	R Bracket; Mild STL, FB/PC	1	07190			

**NOTE: FAILURE TO FOLLOW INSTALLATION INSTRUCTIONS AND NOT USING THE PROVIDED HARDWARE MAY DAMAGE THE INTAKE TUBE, THROTTLE BODY AND ENGINE.**

#### TO START:

1. Turn off the ignition and disconnect the negative battery cable.

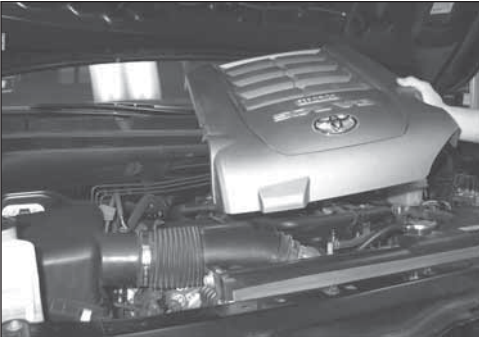

2. Lift up the front of the engine cover and then unhook it from the rear and remove it from the vehicle.

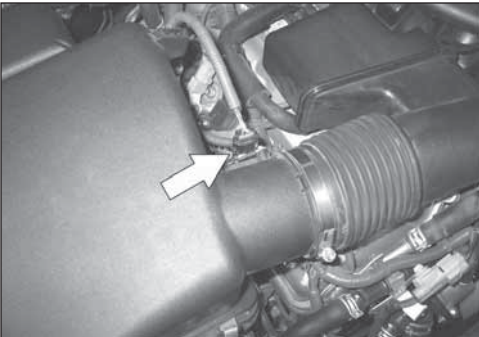

3. Disconnect the mass air sensor electrical connection and then unhook the wiring harness from the air box.

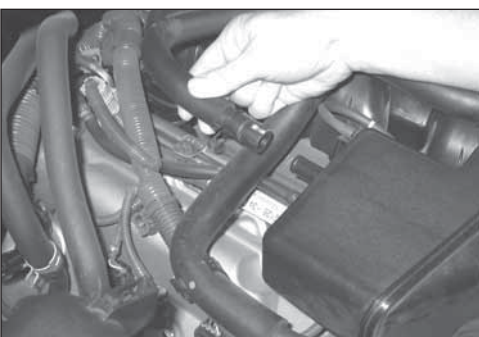

4. Disconnect the crank case vent hose from stock intake tube as shown.



5. Disconnect the fuel pressure regulator vent hose from the stock intake tube as shown.

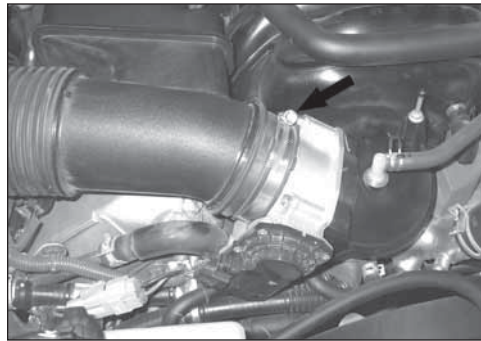

6. Loosen the hose clamp which secures the stock intake tube to the throttle body.

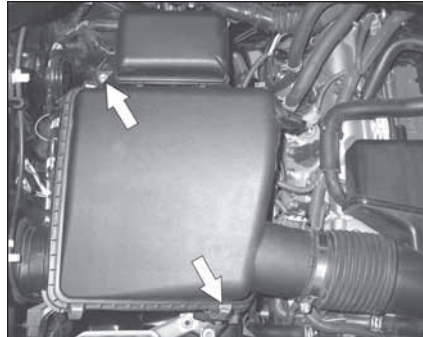

7. Loosen the two bolts which secure the air box to the inner fender.



8. Remove the complete stock intake assembly from the vehicle as shown.

**NOTE: K&N Engineering, Inc., recommends that customers do not discard factory air intake.**

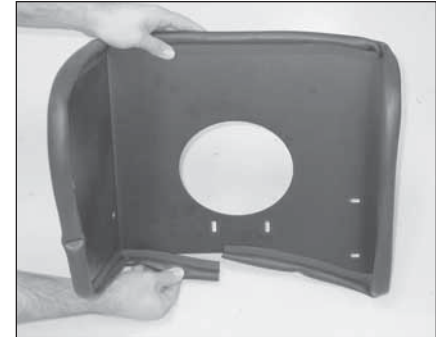

9. Install the large edge trim onto the heat shield as shown.

**NOTE: Some trimming of the edge trim will be necessary.**

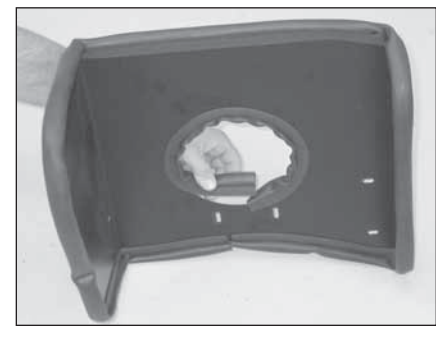

10. Install the small edge trim into the hole of the heat shield as shown.

**NOTE: Some trimming of the edge trim will be necessary.**

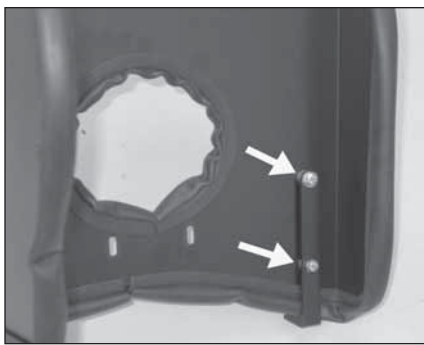

11. Install the large "L" (070902) bracket onto the heat shield as shown using the provided spacers and hardware.

**NOTE: The two spacers are to be installed between the bracket and heat shield.**

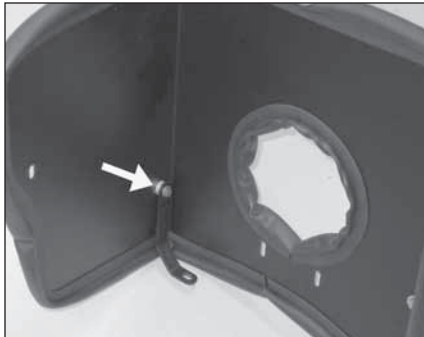

12. Install the small "L" (07190) bracket onto the heat shown with the provided hardware and spacers.

**NOTE: The spacer is to be installed between the bracket and heat shield.**

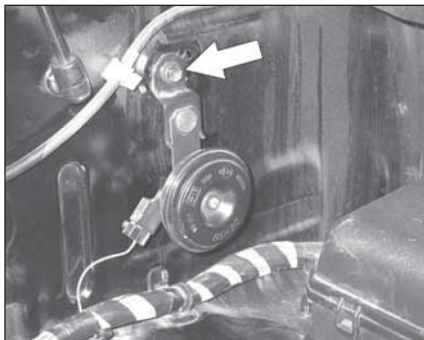

13. On vehicles equipped with a security system horn, remove the bolt which secures the horn to the inner fender.



14. Install the small "L" bracket (070742) onto the inner fender using the hardware provided as shown. **NOTE: On vehicles equipped with the security system horn, be sure to install the "L" bracket over the horn bracket.**



14a. Install the tube mounting bracket on the heat shield as shown using the provided hardware. **NOTE: Be sure to place the provided rubber mounted studs between the heat shield and bracket. Do not completely tighten at this time.**

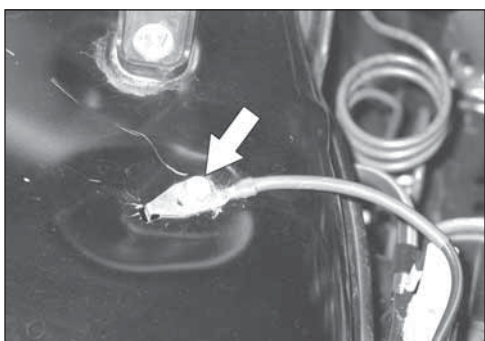

15. Remove the bolt which secures the ground strap to the inner fender.

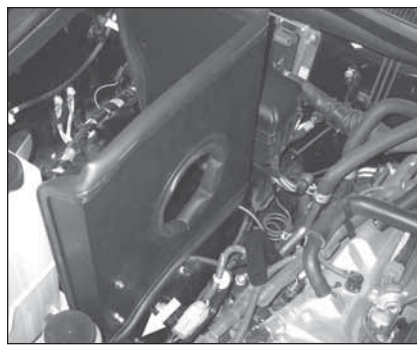

16. Set the heat shield into position on the inner fender. Then secure the front mounting bracket to the front air box mounting location with the provided hardware.



17. Secure the rear lower mounting bracket to the ground strap location with the provided hardware.

**NOTE: Be sure to place the ground strap between the bracket and inner fender.**

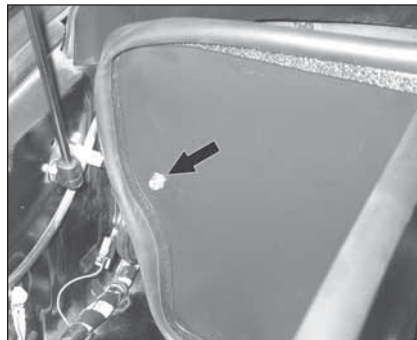

18. Secure the rear heat shield bracket installed during step #15 to the heat shield with the provided spacer and hardware.

**NOTE: The spacer is to be placed between the heat shield and bracket.**

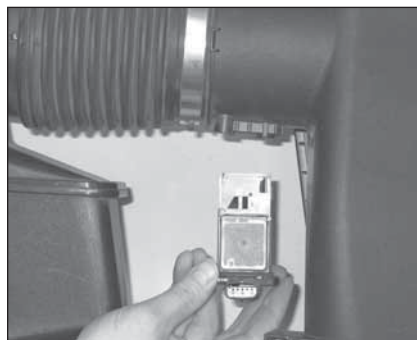

19. Remove the two bolts which secure the mass air sensor into the stock air filter housing and then remove the mass air sensor as shown.



20. Install the mass air sensor into the K&N intake tube using the hardware provided.



20a. Install the two provided 1/4" npt fittings into the K&N intake tube as shown.

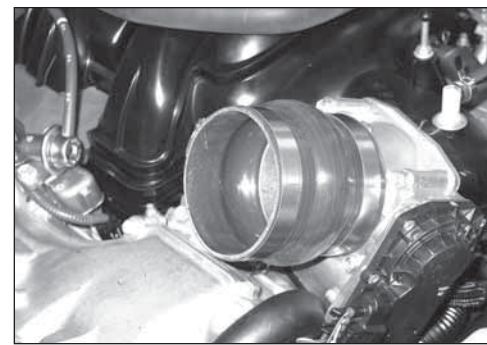

21. Install the silicone hose (084057) onto the throttle body as shown and secure with the provided hose clamp.

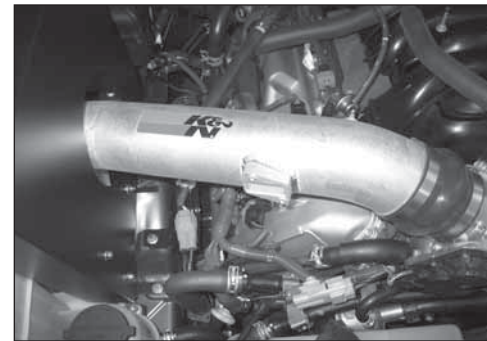

22. Install the K&N intake tube into the silicone hose at the throttle body and align with bracket installed on the heat shield. Align tube and heat shield then tighten the heat shield and secure the intake tube with the provided hardware.

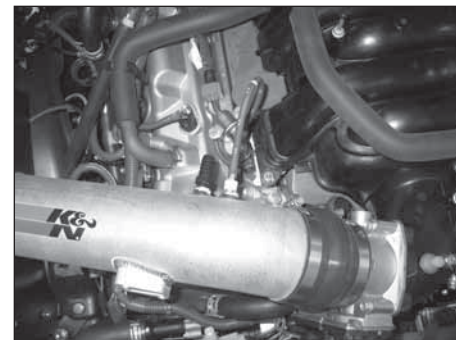

23. Connect the factory fuel pressure vent hose to the K&N intake tube as shown.

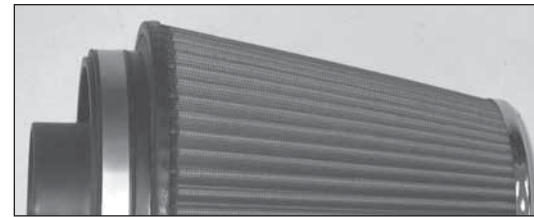

24. Install the provided hose mender into the provided crank case vent hose.

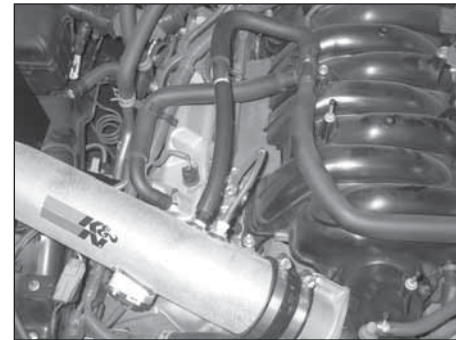

25. Connect the hose mender from the crank case vent hose assembly into the factory crank case vent hose and secure with the factory spring clamp. Then connect the open end to the K&N intake tube as shown.



26. Install the filter adapter into the K&N air filter as shown and secure with the provided hose clamp.



27. Install the provided silicone hose (08630) onto the filter adapter as shown and secure with the provided hardware.

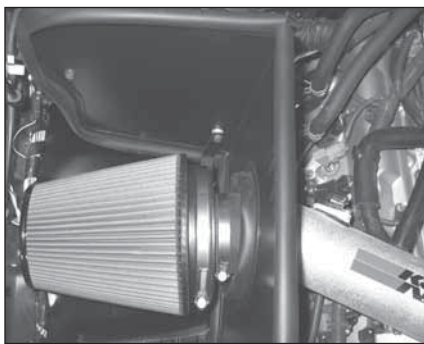

28. Install the K&N® filter assembly onto the K&N® intake tube and secure with the provided hose clamp.



29. Reinstall the engine cover onto the engine.

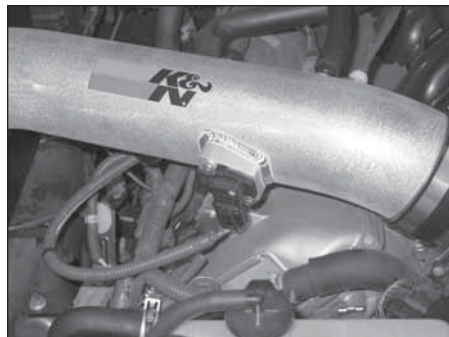

30. Reconnect the mass air sensor electrical connection as shown.



31. Reconnect the vehicle's negative battery cable. Double check to make sure everything is tight and properly positioned before starting the vehicle.

32. It will be necessary for all K&N® high flow intake systems to be checked periodically for realignment, clearance and tightening of all connections. Failure to follow the above instructions or proper maintenance may void warranty.

#### ROAD TESTING:

1. Start the engine with the transmission in neutral or park, and the parking brake engaged. Listen for air leaks or odd noises. For air leaks secure hoses and connections. For odd noises, find cause and repair before proceeding. This kit will function identically to the factory system except for being louder and much more responsive.

2. Test drive the vehicle. Listen for odd noises or rattles and fix as necessary.

3. If road test is fine, you can now enjoy the added power and performance from your kit.

4. K&N Engineering, Inc., suggests checking the air filter element periodically for excessive dirt build-up. When the element becomes covered in dirt (or once a year), service it according to the instructions on the Recharger® service kit, part number 99-5050 or 99-5000.

**STREET LEGAL IN MOST STATES**

**NOT LEGAL FOR USE IN CA & OTHER STATES  
ADOPTING CA EMISSIONS STANDARDS**

**See our catalog or [knfilters.com](http://knfilters.com) for CARB status on each part for a specific vehicle**

\* FREE K&N® decal To register your warranty, please see us online at [knfilters.com/register](http://knfilters.com/register). FREE K&N® decal \*