



INSTALLATION INSTRUCTIONS

77-9029 TOYOTA 2005-08 4RUNNER V8-4.7L

NOTE: This kit was not designed to fit vehicles with a body lift.

TOOLS NEEDED:

- 4mm Socket
- 10mm Socket
- 12mm Socket
- 13mm Socket
- 10mm Wrench
- Extension
- Flat Blade Screwdriver
- Phillips Screwdriver
- Ratchet

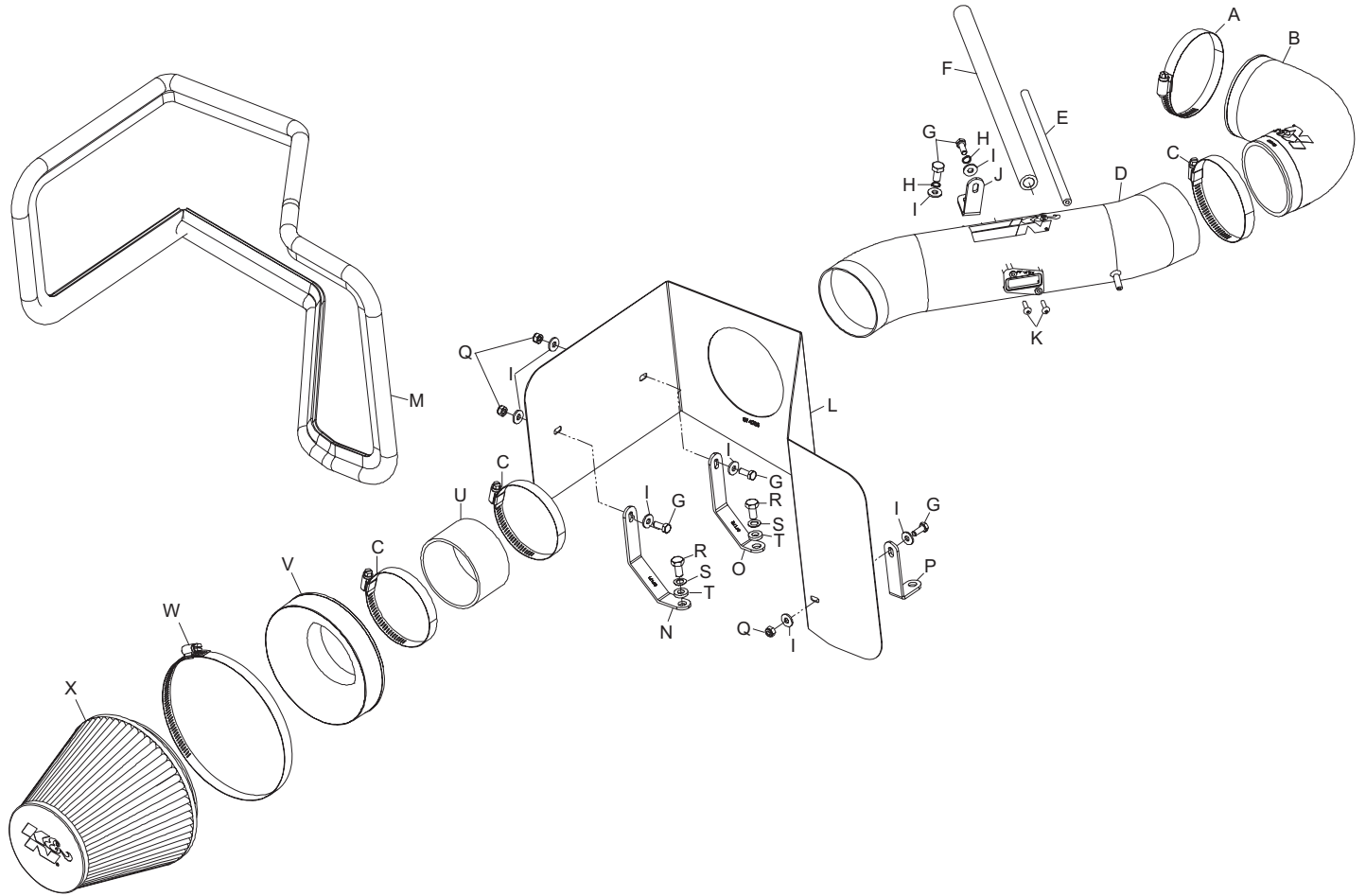

PARTS LIST:

Description	Qty.	Part #	Description	Qty.	Part #	Description	Qty.	Part #
A Hose clamp; #52	1	08610	I Washer; 1/4" id x 5/8" od, flat	8	08275	Q Nut; 6mm nylock	3	07553
B Hose; 3-1/2" id, angled, silicone	1	084089	J Bracket; small "L"	1	070015	R Bolt; 8mm-1.25 x 16mm, hexhead	2	07844
C Hose clamp; #56	3	08620	K Bolt; m4 x .7 x 8mm, b/h/a	2	07741	S Washer; 8mm, wave	2	08239
D Intake tube	1	27191	L Heat shield	1	074005	T Washer; 5/16" id x 5/8" od, flat	2	08276
E Hose; 4mm id x 18" l	1	08153	M Edge trim (83")	1	102503	U Hose; 3-1/2" id x 2" l, silicone	1	08698
F Hose; 1/2" id x 12" l, silicone	1	087031	N Bracket; "U"	1	07171	V Adapter; #380	1	21512
G Bolt; m6-1.00 x 16mm, hex head	5	07703	O Bracket; "U"	1	07172	W Hose clamp #104	1	08697
H Washer; 1/4" id split lock	2	08198	P Bracket; medium "L"	1	07158	X Air filter	1	RF-1048

NOTE: FAILURE TO FOLLOW INSTALLATION INSTRUCTIONS AND NOT USING THE PROVIDED HARDWARE MAY DAMAGE THE INTAKE TUBE, THROTTLE BODY AND ENGINE.

TO START:

1. Turn off the ignition and disconnect the negative battery cable.

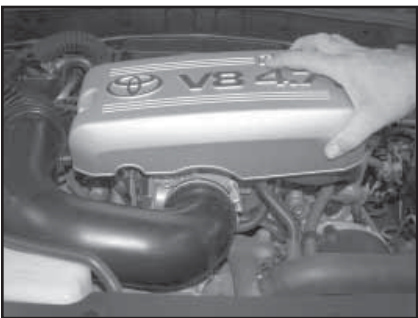

2. Loosen the two nuts that secure the throttle body cover, then remove the throttle body cover

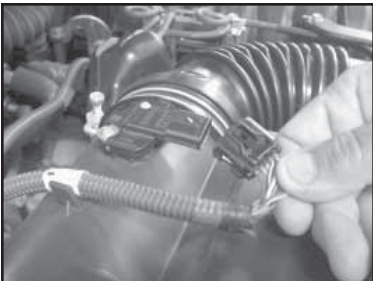

3. Disconnect the mass air sensor electrical connection, then release wire loom from air box.

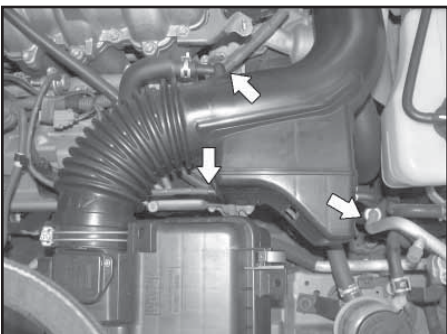

4. Remove the three vent lines from the air intake resonator as shown.

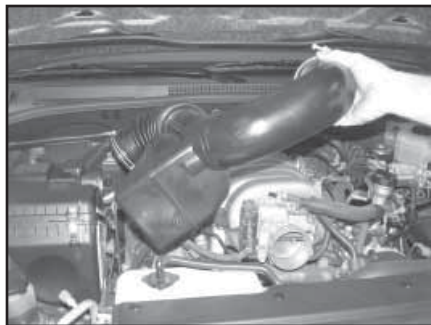

5. Loosen the hose clamp at the throttle body and air box, then remove intake tube from vehicle.

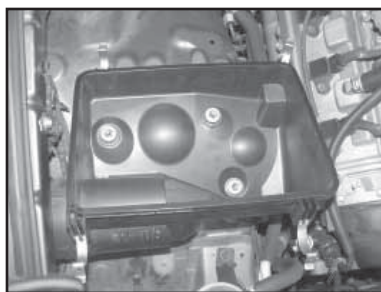

6. Remove the air box lid and filter to gain access to the three bolts that retain the air box to vehicle.



7. Remove the three bolts that retain the air box to vehicle, then remove the air box.
NOTE: K&N Engineering, Inc., recommends that customers do not discard factory air intake.

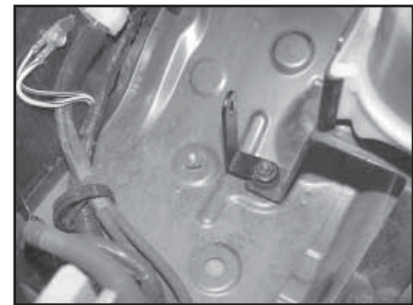

8. Remove the 12mm bolt that retains the power steering reserve to vehicle then mount the provided bracket (07158) onto the vehicle with the bolt that was removed.

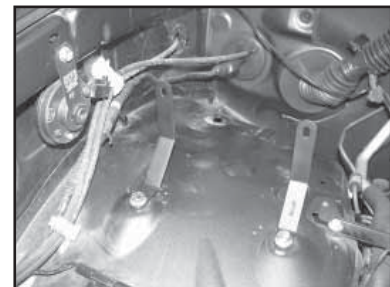

9. Mount the two provided brackets onto the vehicle with the provided hardware.

NOTE: Bracket (07172) mounts closest to engine.



10. Install the edge trim onto the heat shield as shown. Trim if needed.

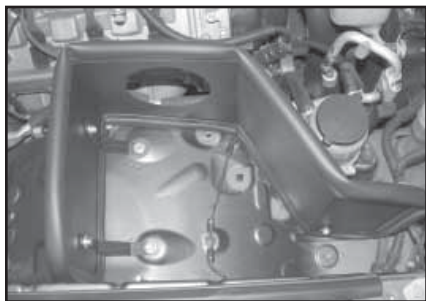

11. Install the heat shield onto the vehicle then secure to brackets with the provided hardware.

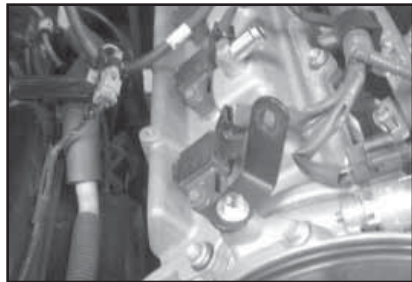

12. Install the small "L" bracket (070015) onto the threaded boss on the cam cover and secure provided bolt.

NOTE: The small leg of the bracket is to attach to the cam cover.

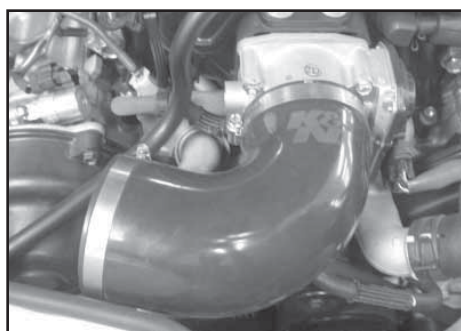

13. Install the silicone hose (084089) onto the throttle body and secure with the provided hose clamp.



14. Remove the two screws that secure the mass air sensor to the air box lid, and then remove the mass air sensor as shown.



15. Secure the mass air sensor to the K&N® intake tube with the provided screws as shown.

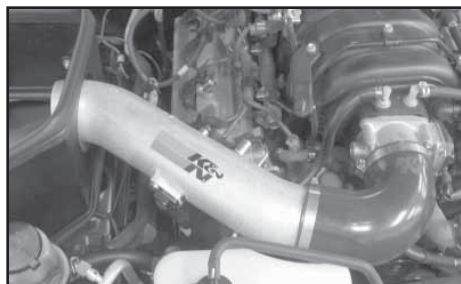

16. Install the K&N® intake tube into the throttle body and align with the mounting bracket installed in step #12. Secure with the provided hardware.

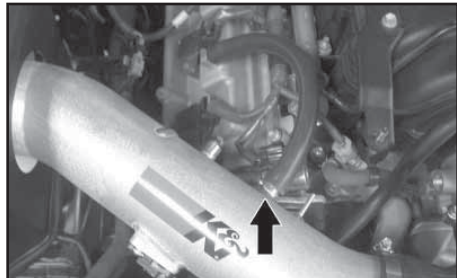

17. Remove the factory crank case vent hose from the valve cover and then install the supplied vent hose onto the valve cover and K&N® intake tube as shown.

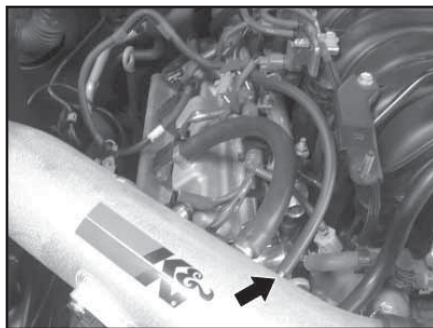

18. Connect the supplied fuel pressure regulator vent hose to the fuel pressure regulator and then onto the K&N® intake tube as shown.



19. Connect the factory power steering pressure switch vent hose onto the K&N® intake tube as shown.



20. Install the filter adapter into the K&N® air filter as shown and secure with the provided hose clamp.



21. Install the silicone hose (08698) onto the K&N® air filter assembly and secure with the provided hose clamp.

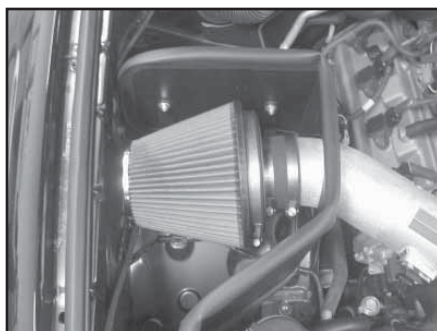

22. Install the air filter assembly onto the K&N® intake tube as shown and secure with the provided hose clamp.



23. Disconnect the ground strap that's attached to the mass air sensor wiring harness at the inner fender as shown.

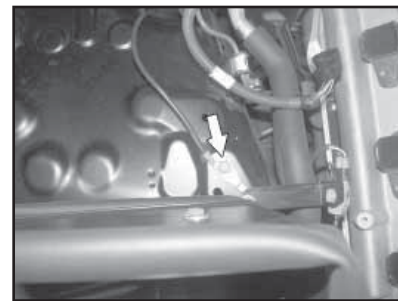

24. Using the bolt that was removed in the previous step, connect the ground strap to wheel well as shown.



25. Reconnect the mass air sensor electrical connection as shown.



26. Reinstall the throttle body cover as shown.



27. Reconnect the vehicle's negative battery cable. Double check to make sure everything is tight and properly positioned before starting the vehicle.

28. It will be necessary for all K&N® high flow intake systems to be checked periodically for realignment, clearance and tightening of all connections. Failure to follow the above instructions or proper maintenance may void warranty.

ROAD TESTING:

1. Start the engine with the transmission in neutral or park, and the parking brake engaged. Listen for air leaks or odd noises. For air leaks secure hoses and connections. For odd noises, find cause and repair before proceeding. This kit will function identically to the factory system except for being louder and much more responsive.

2. Test drive the vehicle. Listen for odd noises or rattles and fix as necessary.

3. If road test is fine, you can now enjoy the added power and performance from your kit.

4. K&N Engineering, Inc., suggests checking the air filter element periodically for excessive dirt build-up. When the element becomes covered in dirt (or once a year), service it according to the instructions on the Recharger® service kit, part number 99-5050 or 99-5000.

STREET LEGAL IN MOST STATES

NOT LEGAL FOR USE IN CA & OTHER STATES ADOPTING CA EMISSIONS STANDARDS

See our catalog or knfilters.com for CARB status on each part for a specific vehicle

FREE K&N® decal To register your warranty, please see us online at knfilters.com/register. FREE K&N® decal