

## INSTALLATION INSTRUCTIONS

### 77-9015

#### TOYOTA

1999-04 TACOMA

1999-02 4RUNNER

V6-3.4L

**NOTE:** This kit was not designed to fit vehicles with a body lift.

#### TOOLS NEEDED:

Ratchet  
Extension  
10mm Socket  
12mm Socket  
13mm Socket  
10mm Wrench  
17mm Wrench  
2.5 Allen  
9/64" Allen Wrench  
Flat Blade Screwdriver  
Phillips Screwdriver

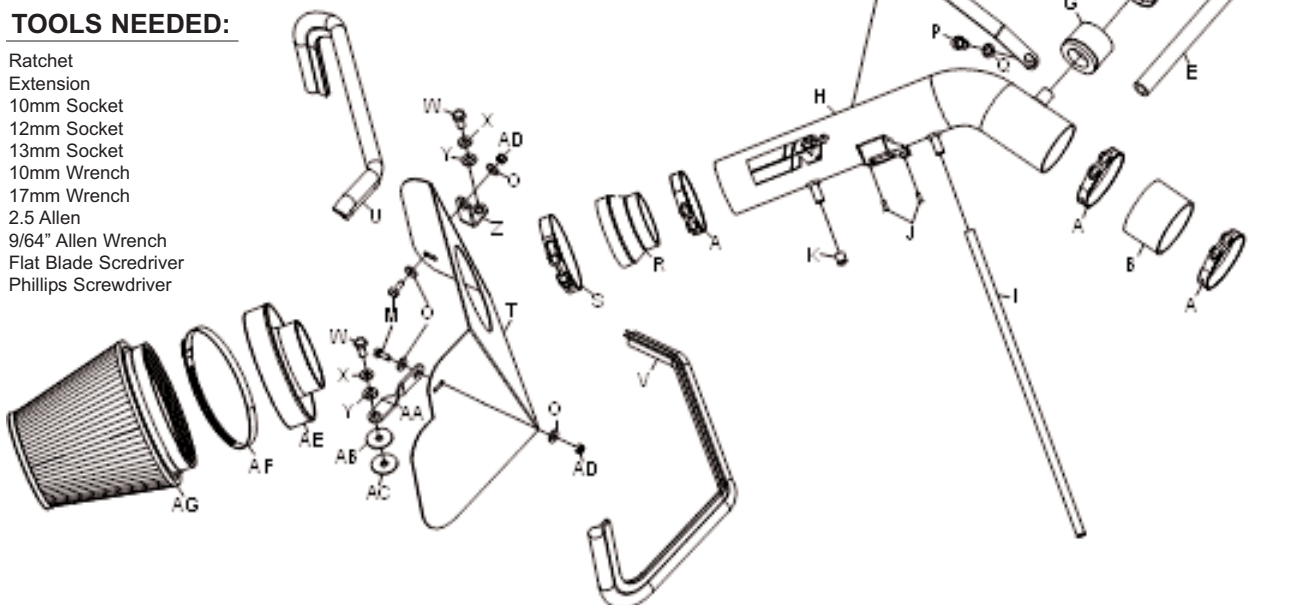

#### PARTS LIST:

Desc.	Qty.	Part #
A	Hose clamp; #44	3 08577
B	Hose; 2-3/4" x 2"L, black	1 08440
C	Hose mender; 1/2" to 5/8"	1 08726
D	Hose clamp; #6 mini	1 08407
E	Hose; 1/2" id x 9"L, black	1 08401
F	Hose clamp; #24	1 08460
G	Grommet	1 08285
H	intake tube	1 27176
I	Hose; 6mm" id x 16"L black	1 08170
J	Screw; m4-.7 x 12mm, button head	2 07726
K	Caplug; 5/16" id 1/2"L, black	1 08131
L	Bracket; large twist	1 070561
M	Bolt; m6-1.00 x 16mm hex head	3 07703
N	Washer; 1/4 split lock	1 08198
O	Washer; 1/4" id x 5/8" od, flat	5 08275
P	Bolt; m10-1.25 x 16mm hex head	1 071002
Q	Washer; 10mm wave	1 08175
R	Hose; 2-1/2" to 3-1/4" x 2"L, step, black	1 084093
S	Hose clamp; #56	1 08620
T	heat shield	1 07435
U	edge trim 20"	1 102494
V	edge trim 26"	1 102488
W	Bolt; 8mm-1.25 x 20mm hex head	2 07787
X	Washer; 8mm wave	2 08239
Y	Washer; 5/16" id x 5/8" od, flat	2 08276
Z	Bracket; small "L"	1 070712
AA	Bracket; short twist	1 070702
AB	Washer; 5/16" id x 1.25" od, fender	1 08130
AC	Washer; 1.25" x .30" x .10", rubber	1 21708
AD	Nut; 6mm nylock	2 07553
AE	Filter adapter; #380	1 21512
AF	Hose clamp #104	1 08697
AG	Air filter	1 RF-1042

**NOTE: FAILURE TO FOLLOW INSTALLATION INSTRUCTIONS AND NOT USING THE PROVIDED HARDWARE MAY DAMAGE THE INTAKE TUBE, THROTTLE BODY AND ENGINE.**

#### TO START:

1. Turn the ignition OFF and disconnect the vehicle's negative battery cable.



2. Disconnect the mass air sensor.



3. Disconnect the three hoses from the air box resonator and intake hose.

**NOTE: Some 03 models may only come equipped with two vent lines**



4. Loosen the hose clamps at the throttle body.



5. Loosen the three bolts that retain the air box assembly.



6. Remove the complete air intake system.



7. On vehicles equipped with the crank case vent resonator chamber, loosen the hose clamp which secures the chamber to the intake tube and remove the chamber from the tube as shown.



8. On vehicles equipped with the crank case resonator chamber, using a 1-3/8" hole saw, drill out the 5/8" vent port as shown.

**NOTE: Be sure to remove any burrs in the hole after drilling.**



9. Install the resonator grommet provided into the 1-3/8" hole drilled in step #8 as shown.

**NOTE: The grommet may seem hard to install; this is done to provide air tight seal.**



10. Install the crank case vent resonator into the grommet install in step #9 and secure with the provided hose clamp.



11. Loosen and remove the screws that secure the mass air sensor, then remove the mass air sensor.



12. Install the mass air sensor into the K&N intake tube and secure with the provided hardware.



13. Install the two pieces of edge trim onto the heat shield as shown above.



14. Install the "L" bracket onto the existing air box-mounting hole. (NOTE: Rubber washer & fender washer should be mounted between the fender and the bracket.) Do not tighten completely.



15. Install the twist bracket onto the existing air box-mounting hole with the provided hardware as shown. Do not tighten completely.



16. Install the tube-mounting bracket onto engine with the supplied hardware as shown. **NOTE: The bracket will bolt to the threaded boss next in the cylinder head next to the power steering pump bracket.**



17. Install the heat shield and secure it to the new K&N brackets with the hardware provided as shown. Do not tighten completely.



18. Install the silicone hose (08440) onto the throttle body with the provided hose clamps as shown.



19. Install the K&N intake tube onto the throttle body and align with the tube mounting bracket installed in step #16. Secure the tube with the provided hardware to the mounting bracket and tighten the hose clamp at the throttle body.



20. Install the provided silicone hose onto the engine and connect it to the K&N intake tube as shown. Then attach the vent line from EVAP canister to the K&N intake tube as shown.

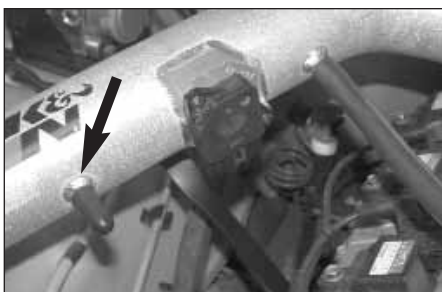

21. On the vehicles that are not equipped with the EVAP canister, use the provided plug on the extra vent port as shown.

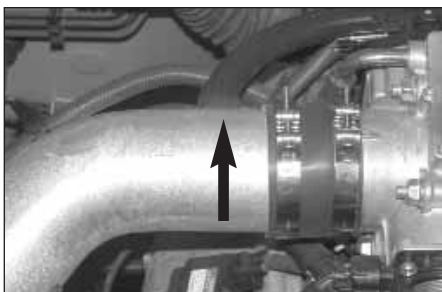

22. On vehicles not equipped with the crank case vent resonator, attach the provided silicone hose onto the crankcase vent and secure with the provided hose clamp. Then connect it to the K&N intake tube as shown.



23. On vehicles equipped with crank case vent resonator, connect the factory crank case vent hose onto the resonator as shown. **NOTE: The crank case vent hose may need to be repositioned to enable it to reach the resonator.**



24. Install the air filter adapter into the air filter as shown.



25. Install the silicone hose (084093) onto the air filter assembly as shown and secure with the provided hose clamps.



26. Install the air filter assembly onto the K&N intake tube and secure with the provided hose clamp.



27. Reconnect the mass air sensor electrical connection.



28. Reconnect the negative battery cable and double check to make sure everything is tightened and properly positioned before starting the vehicle.

29. The C.A.R.B. exemption sticker, (attached), must be visible under the hood so that an emissions inspector can see it when the vehicle is required to be tested for emissions. California requires testing every two years, other states may vary.

30. It will be necessary for all intakes to be checked periodically for realignment, clearance and tightening of all connections. Failure to follow the above instructions or proper maintenance may void warranty.

#### ROAD TESTING:

1. Start the engine with the transmission in neutral or park, and the parking brake engaged. Listen for air leaks or odd noises. For air leaks secure hoses and connections. For odd noises, find cause and repair before proceeding. This kit will function identically to the factory system except for being louder and much more responsive.

2. Test drive the vehicle. Listen for odd noises or rattles and fix as necessary.

3. If road test is fine, you can now enjoy the added power and performance from your kit.

4. K&N suggests checking the air filter element periodically for excessive dirt build-up. When the element becomes covered in dirt (or once a year), service it according to the instructions on the Recharger service kit, part number 99-5050 or 99-5000.

**50-STATE STREET LEGAL**  
**K&N CARB EXEMPT**

\*FREE K&N DECAL To register your warranty, please see us online at [knfilters.com/register](http://knfilters.com/register). FREE K&N DECAL\*