

INSTALLATION INSTRUCTIONS

77-2557
Ford
2004-05 F-150
V8-4.6L

NOTE: This kit was not designed to fit vehicles with a body lift.

TOOLS NEEDED:

Ratchet
Extension
10mm Socket
13mm Socket
14mm Socket
10mm Wrench
13mm Wrench
4mm Allen Wrench
9/64" Allen
Flat Blade Screw Driver

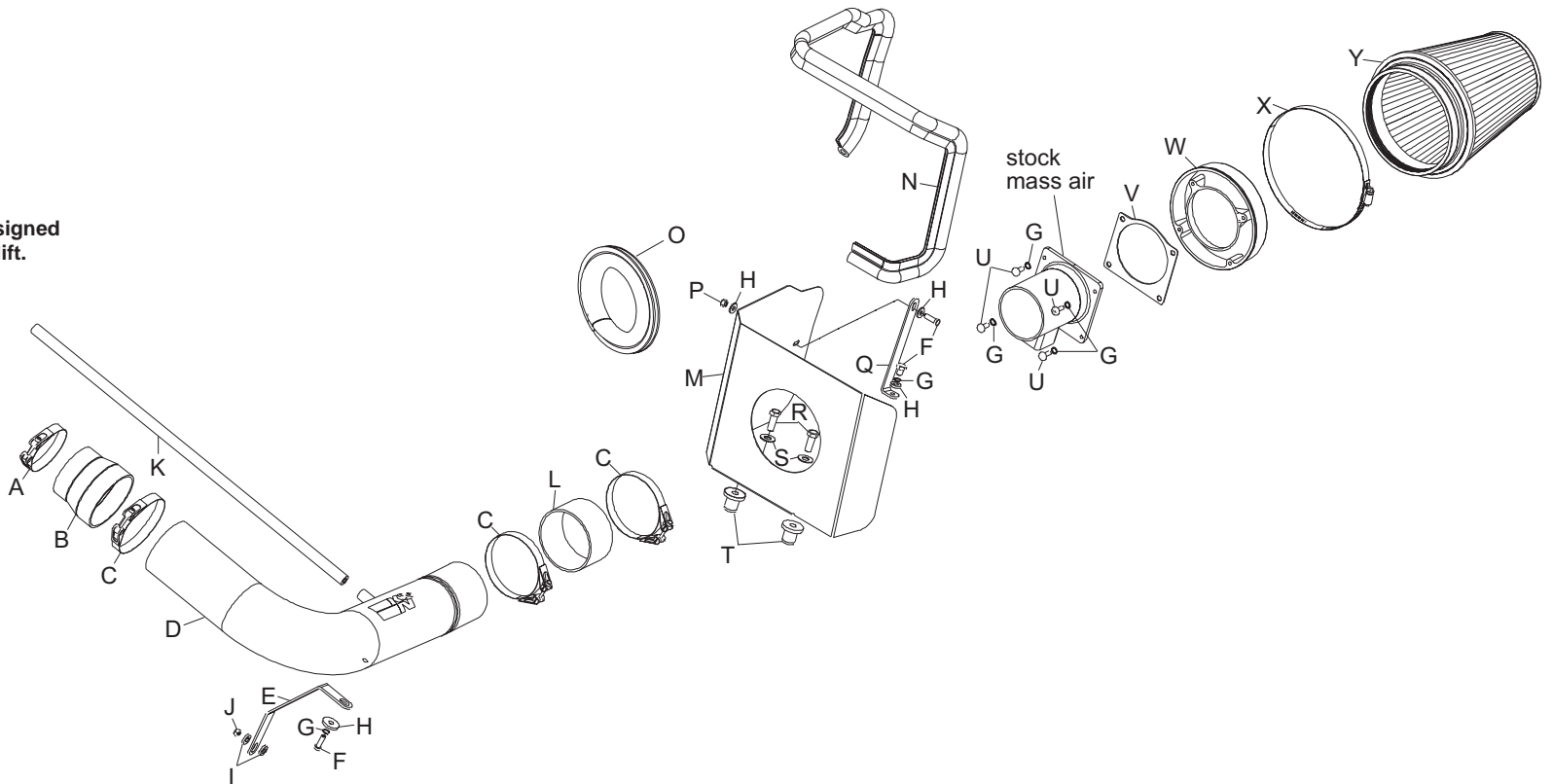

PARTS LIST:

Description	Qty.	Part #	Description	Qty.	Part #	Description	Qty.	Part #
A hose clamp #48	1	08601	H washer; 1/4" id x 5/8" od, flat	4	08275	O edge trim 17"	1	102469
B step hose	1	084055	I washer; 5/16" id x 5/8" od	2	08276	P nut; 6mm nylock	1	07553
C hose clamp #56	3	08620	J nut; 8mm nylock	1	07542	Q bracket; "L"	1	070026
D intake tube	1	27183	K hose; 5/8" id x 19" l, silicone	1	08611	R bolt; 3/8"-16 x 1.25" L, hex	2	07779
E bracket; "C"	1	07198	L silicone hose	1	08698	S washer; 3/8" id, flat	2	08134
F bolt; 6mm-1.00" id x 16mm, hex	3	07703	M heat shield	1	074021	T insert; 3/8"-16 x 3/4" x 15/16" l	2	08163
G washer; 1/4" id split lock	6	08198	N edge trim 55"	1	102480	U bolt; 6mm-1.00" id x 16mm, btnn allen	4	07730
						V gasket; mass air sensor	1	09984
						W filter adapter #250	1	08785
						X hose clamp #104	1	08697
						Y air filter	1	RF-1020

NOTE: FAILURE TO FOLLOW INSTALLATION INSTRUCTIONS AND NOT USING THE PROVIDED HARDWARE MAY DAMAGE THE INTAKE TUBE, THROTTLE BODY AND ENGINE.

TO START:

1. Turn off the ignition and disconnect the negative battery cable.



2. Rotate the crank case vent hose locking ring and pull the crank case vent hose off of the valve cover.

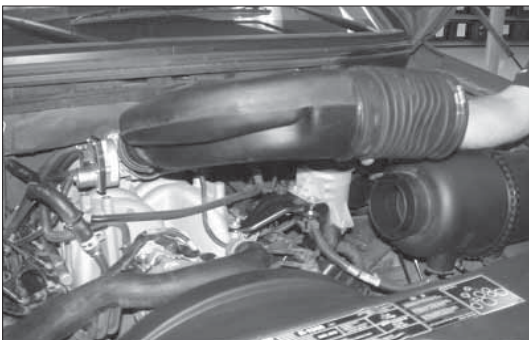

3. Loosen the stock intake tube hose clamps, and remove the intake tube from vehicle.



4. Unhook the secondary mass air sensor electrical connection from the power steering reservoir bracket, then unlock the electrical connection locking tabs and separate the electrical connection.

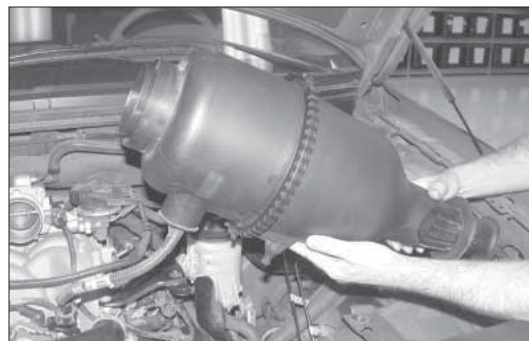

5. Pull firmly up on the air filter assembly to remove it from the mounting grommets.
NOTE: K&N Engineering, Inc., recommends that you do not discard your factory air intake.

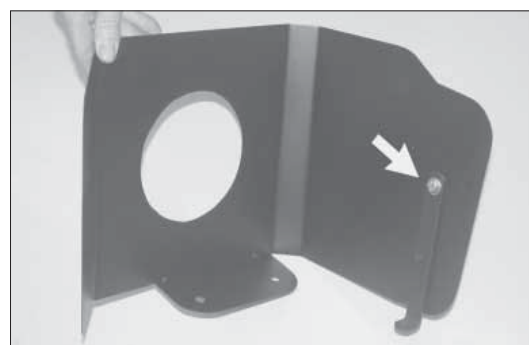

6. Install "L" bracket (070026) onto the heatshield with the hardware provided as shown.

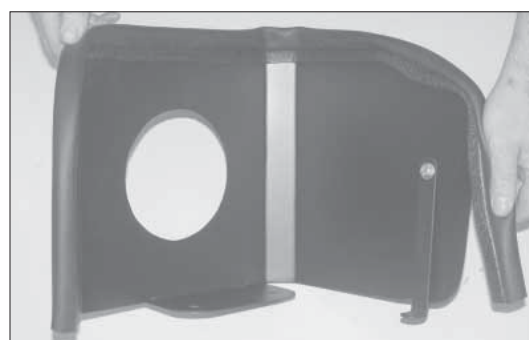

7. Install the edge trim onto the heatshield as shown. Trim if needed.



8. Install the edge trim into the hole in the heat shield as shown.
NOTE: Some trimming of the edge trim may be necessary.



9. Install the provided nut inserts into the air box mounting holes as shown.

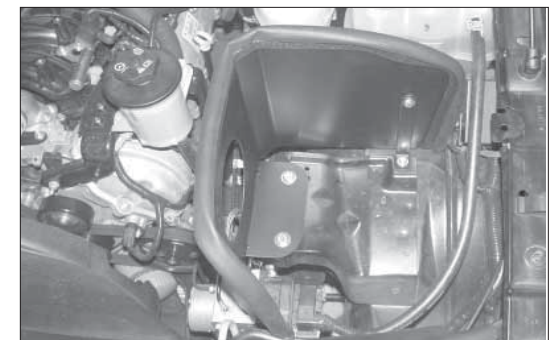

10. Install the heatshield as shown and secure with the provided hardware.

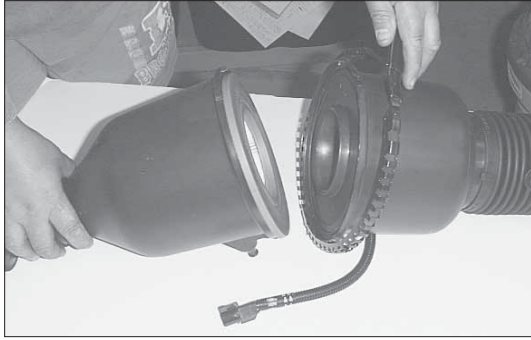

11. Open the air cleaner assembly and isolate the mass air sensor assembly.



12. Slide the rubber grommet back and disconnect the primary mass air sensor electrical connection, using a flat blade screwdriver.

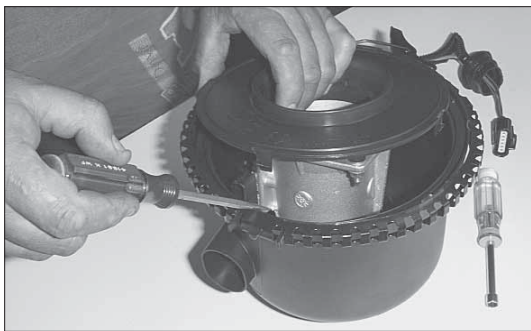

13. Using a flat blade screwdriver, push in and release the four clips that retain the mass air sensor retaining plate.



14. Using a pair of small vise grips or pliers, hold the stud while using a 10mm wrench to loosen the nuts, then remove the mass air sensor from the retaining plate.



15. Attach the mass air adapter to the mass air sensor using the gasket and hardware provided as shown.

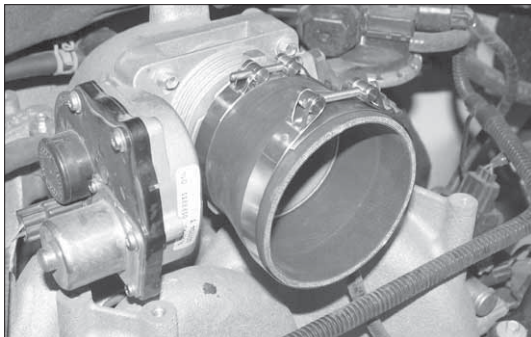

16. Install the silicone hose (084055) onto the throttle body with the hose clamps provided as shown.

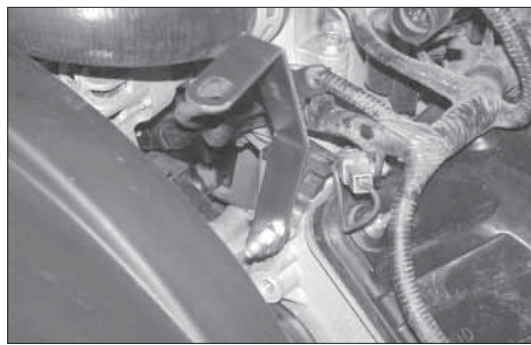

17. Install the tube mounting bracket (07198) onto the 8mm stud protruding from the engine with two flat washers and 8mm nut provided.



18. Install the silicone hose (08698) onto the K&N® intake tube and secure with the provided hose clamp as shown.

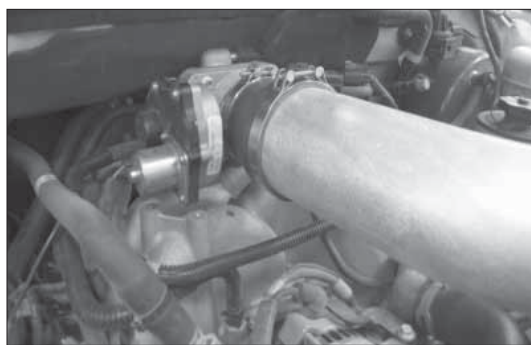

19. Install the K&N® intake tube into the silicone hose at the throttle body and secure with the provided hose clamp.

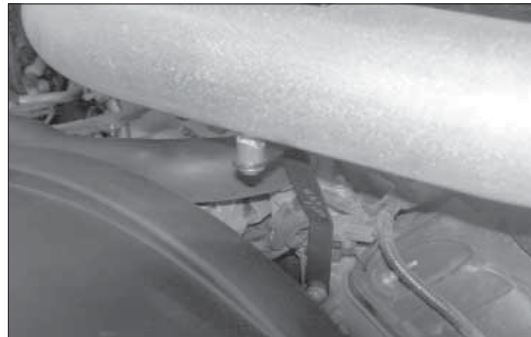

20. Attach the K&N® intake tube to the mounting bracket installed in step #17.

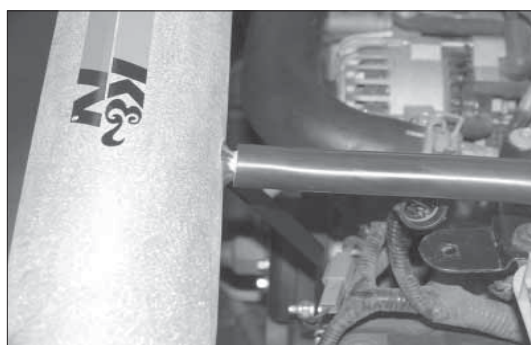

21. Install the provided silicone vent hose onto the valve cover and onto the K&N® intake tube as shown.

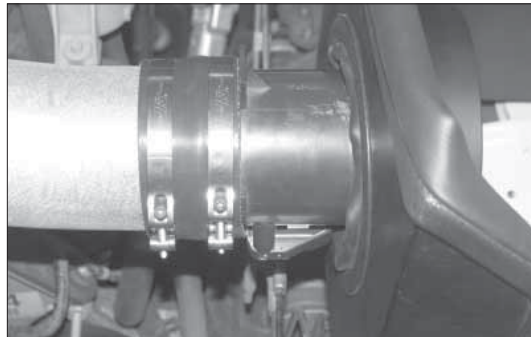

22. Install the mass air sensor assembly onto the K&N® intake tube and secure with the provided hose clamp.

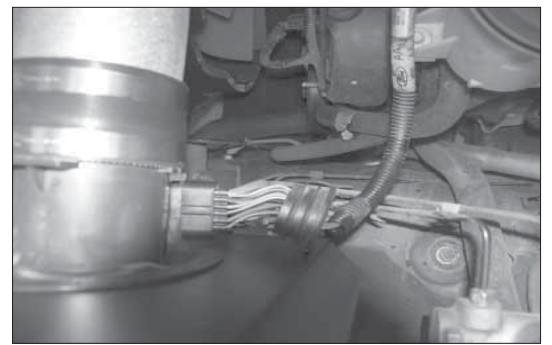

23. Reconnect the primary and secondary mass air sensor electrical connections.

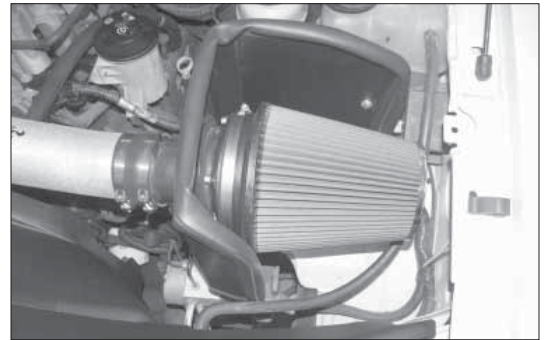

24. Install the K&N® air filter and secure with the provided hose clamp.

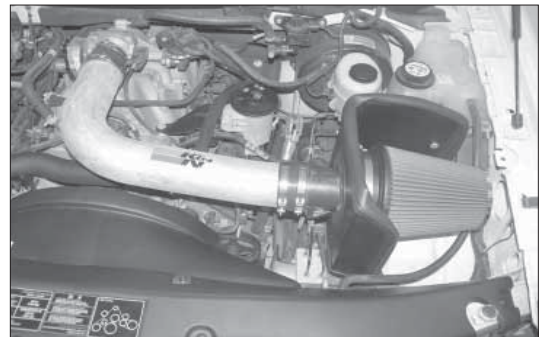

25. Reconnect the vehicle's negative battery cable. Double check to make sure everything is tight and properly positioned before starting the vehicle.

26. The C.A.R.B. exemption sticker, (attached), must be visible under the hood so that an emissions inspector can see it when the vehicle is required to be tested for emissions. California requires testing every two years, other states may vary.

27. It will be necessary for all K&N® high flow intake systems to be checked periodically for realignment, clearance and tightening of all connections. Failure to follow the above instructions or proper maintenance may void warranty.

ROAD TESTING:

1. Start the engine with the transmission in neutral or park, and the parking brake engaged. Listen for air leaks or odd noises. For air leaks secure hoses and connections. For odd noises, find cause and repair before proceeding. This kit will function identically to the factory system except for being louder and much more responsive.

2. Test drive the vehicle. Listen for odd noises or rattles and fix as necessary.

3. If road test is fine, you can now enjoy the added power and performance from your kit.

4. K&N Engineering, Inc., suggests checking the air filter element periodically for excessive dirt build-up. When the element becomes covered in dirt (or once a year), service it according to the instructions on the Recharger® service kit, part number 99-5050 or 99-5000.

50-STATE STREET LEGAL
K&N CARB EXEMPT

* FREE K&N® decal To register your warranty, please see us online at knfilters.com/register. FREE K&N® decal *

• 1455 CITRUS ST., P.O. BOX 1329, RIVERSIDE, CA., U.S.A. 92502 • TECH SERVICE 800-858-3333 • FAX 951-826-4001
 • e-mail: tech@knfilters.com • WWW: <http://www.knfilters.com>

18336i
 3/8/10