

# TYPHOON INTAKE SYSTEMS



## INSTALLATION INSTRUCTIONS

### 69-9756

**Volkswagen:** Golf V/Jetta/Eos/Touran/  
Caddy III 1.9/2.0 TDi 2004-  
Passat 1.9/2.0 TDi 2005-

**Skoda:** Octavia II 1.9/2.0 TDi 2004-  
Octavia II 1.8TFSi 2007-

**Seat:** Altea/Toledo/Leon II 1.9/2.0 TDi 2004-  
Altea/Toledo/Leon II 1.8 TFSi 2007-

**Audi:** A3 II 1.9/2.0 TDi 2003-  
A3 II 1.8TFi 2006-

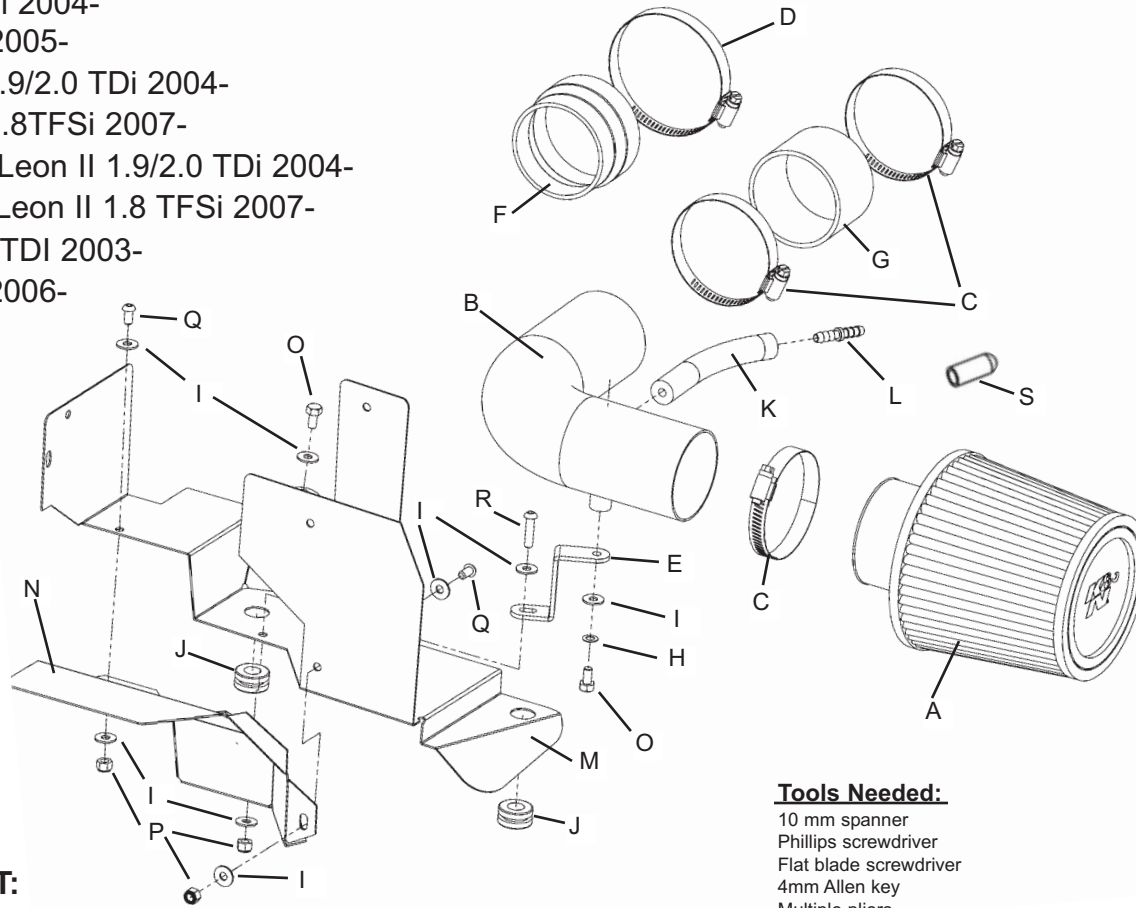

### PARTS LIST

	Description	Qty.	P/N
A	Filter Charger	1	KRU4960E
B	Typhoon Intake Tube	1	27449
C	Hose clamp #44	3	08560
D	hose clamp #48	1	08601
E	Bracket "Z"	1	070058
F	Sleeve 2-3/4" to 3"	1	084036
G	Sleeve 2-3/4" x 2"L	1	08756
H	Washer waved M6	1	08277
I	Washer 6mm Flat	8	08269
J	Rubber grommet	2	08064
K	Vent hose 1/4" ID	1	08716
L	Vent plug	1	08703
M	Heat shield A	1	07350
N	Heat shield B	1	07351
O	Bolt; M6 x 12mm	2	07727
P	Nut M6; nylock	3	07512
Q	Bolt; M6 x 16mm button	2	07794
R	Bolt; M6 x 25 button	1	07729
S	Rubber tip	1	08215

**NOTE: FAILURE TO FOLLOW INSTALLATION INSTRUCTIONS AND NOT USING THE PROVIDED HARDWARE MAY DAMAGE THE INTAKE TUBE, THROTTLE BODY AND ENGINE.**

**Tools Needed:**  
10 mm spanner  
Phillips screwdriver  
Flat blade screwdriver  
4mm Allen key  
Multiple pliers

### TO START:

1. Turn the ignition OFF and disconnect the vehicle's negative battery terminal.



2. Disconnect the Mass Air Sensor (MAS) electrical connection as shown.



3. **TDI's Only:** Remove the vacuum hose from the top or the side of the air box as shown.



4. Unclip and remove the intake snorkel lid as shown.



5. Unclip and remove the intake snorkel as shown.

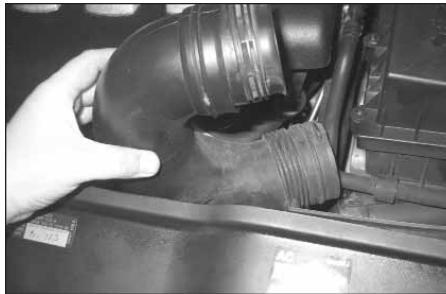

6. Unclip and remove the air box feed pipe from the vehicle as shown.



7. Unclip the intake hose clamp from the MAS as shown.



8. Unbolt and remove the air box assembly from the vehicle as shown.



9. Remove the MAS from the airbox as shown.



10. Refit the MAS to the engine's intake using its original hose clamp as shown.



11. Fit the sleeve supplied to the MAS using the hose clamps supplied.  
**1.9 TDi & 1.8TFSi use the small sleeve.**  
**2.0 TDi use the large sleeve.**

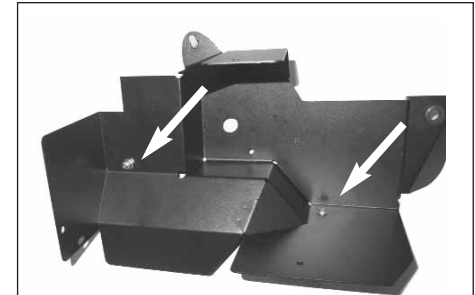

12. Install the 2 heat shields using the 2 short M6 Allen bolts, and M6 washers supplied.

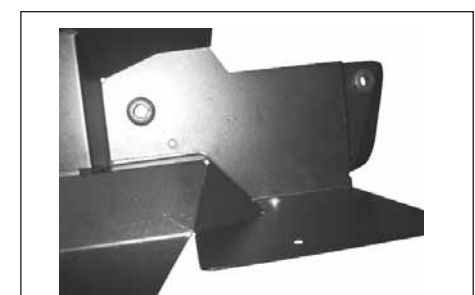

13. Fit the rubber grommets into the 2 holes of the heat shield as shown.

**Continue on reverse side!**



14. Clamp the heat shield onto the air box support bracket as shown.



15. Fit the heat shield to the air box support bracket using a M6 bolt and a flat M6 washer supplied.



16. Mount the filter onto the intake tube using the hose clamp supplied.

**NOTE: Before installing clean the inside of the tube with water and a towel.**



17. Fit the bracket to the intake tube as shown using the M6 Nylock nut, waved washer and flat metal washer supplied. Don't fully tighten yet!



18. Fit the intake tube into the sleeve using the hose clamp supplied. Do not fully tighten at this moment.



19. Fit the bracket to the heat shield using the large M6 bolt, M6 washer supplied. Do not fully tighten yet!

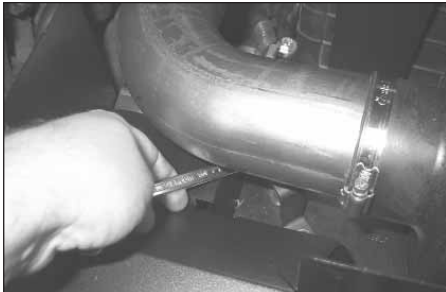

20. Align the Typhoon tube and filter for the best clearance and tighten all bolts and clamps.



21. **TDI's Only:** Fit the vent plug onto the original vacuum hose and extend it using the small vacuum hose supplied. Fit the vacuum hose to the intake tube as shown.



22. **TFSi and TSi Only:** Fit the vent plug supplied onto the intake tube as shown.

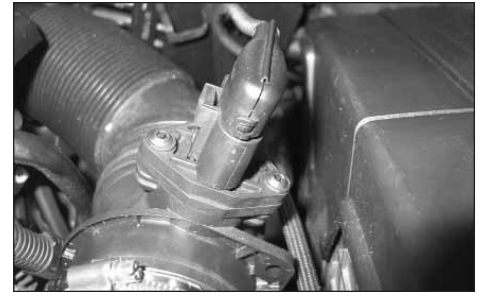

23. Refit the MAS plug to the MAS as shown.



24. Reconnect the vehicle's negative battery cable. Installation is now complete.

25. Double check to make sure everything is tight and properly positioned before starting the vehicle.

26. It will be necessary for all Typhoons to be checked periodically for realignment, clearance and tightening of all connections. Failure to follow the above instructions or proper maintenance may void warranty.

#### ROAD TESTING:

1. Start the engine with the transmission in neutral or park, and the parking brake engaged. Listen for air leaks or odd noises. For air leaks secure hoses and connections. For odd noises, find cause and repair before proceeding. This kit will function identically to the factory system except for being louder and much more responsive.
2. Test drive the vehicle. Listen for odd noises or rattles and fix as necessary.
3. If road test is fine, you can now enjoy the added power and performance from your kit.
4. K&N suggests checking the Filtercharger element periodically for excessive dirt build-up. When the element becomes covered in dirt (or once a year), service it according to the instructions on the Recharger service kit available from your K&N dealer, part number 99-5003EU.

