



TYPHOON INTAKE SYSTEMS



INSTALLATION INSTRUCTIONS

69-8004 SUBARU 2008-11 WRX L4- 2.5L Turbo

NOTE: C.A.R.B. E.O. # D-269-37 APPLIES ONLY TO 2008-10 MODEL YEAR VEHICLES.

TOOLS NEEDED:

- 3mm Allen Wrench
- 10mm Allen Wrench
- 10mm Socket
- Extension
- Flat Blade Screwdriver
- Phillips Screwdriver
- Ratchet

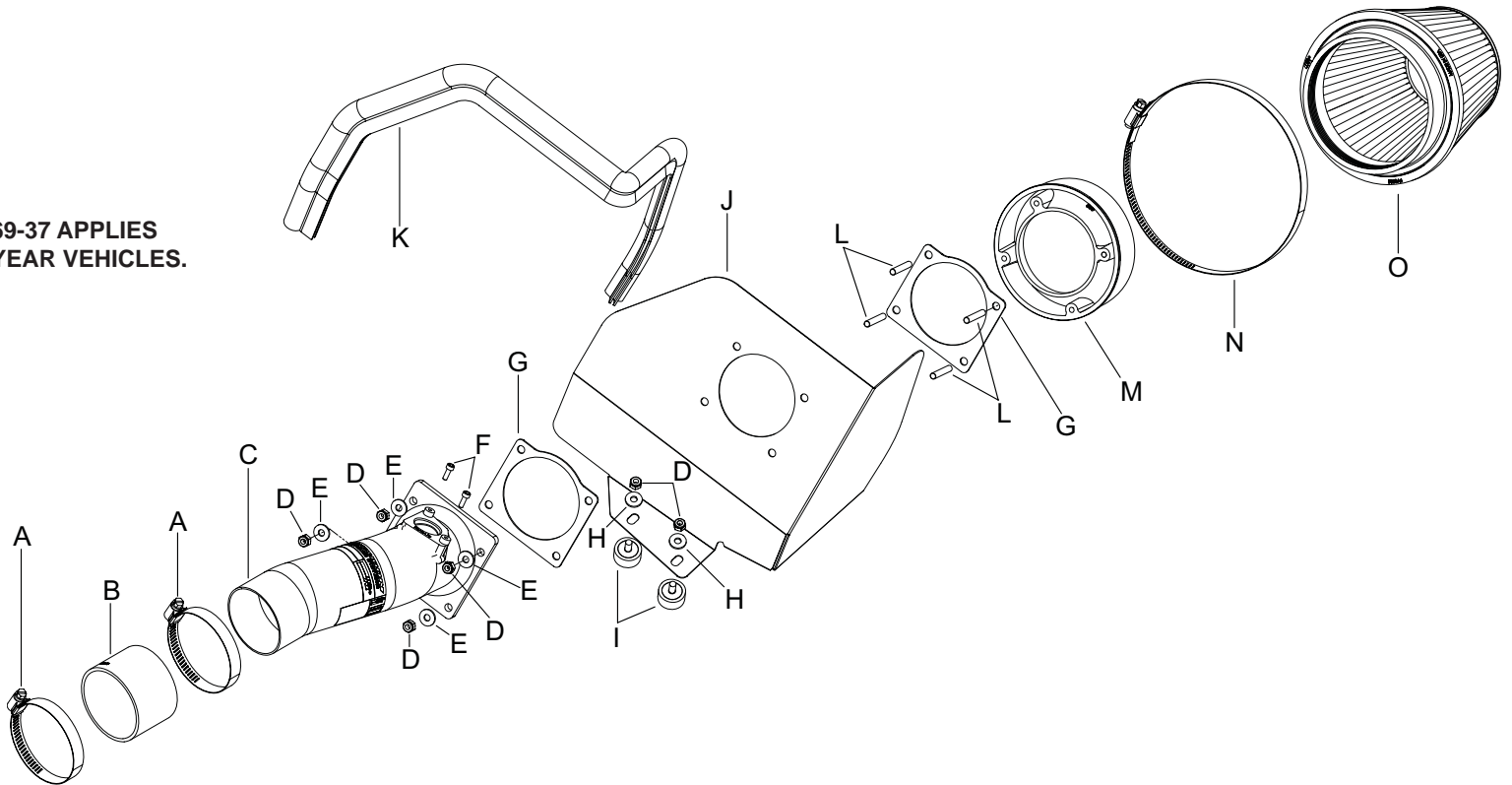

PARTS LIST:

Description	Qty.	Part #	Description	Qty.	Part #	Description	Qty.	Part #
A Hose Clamp #44	2	08560	F Bolt; M4 - 0.07 8MM, A/H CAP, SS	2	07733	K Edge Trim	1	102486
B Hose; 2-3/4" x 2"L, Blk.	1	08440	G Gasket; 1/16"	2	09202	L Stud; 6MM-1.00 X 35MM L, SS	4	08220
C Intake Tube	1	27440	H Washer; 1/4"ID X 5/8"OD - SAE	2	08275	M Adaptor; #350	1	21510
D Nut; 6MM Nylock, Hex., SS	6	07512	I Stud; 6-1.00 M/M, Mntd.	2	07027	N Hose clamp #80	1	08694
E Washer; 6MM Flat, SS	4	08269	J Heat Shield	1	07685	O Air Filter	1	RP-5113

NOTE: FAILURE TO FOLLOW INSTALLATION INSTRUCTIONS AND NOT USING THE PROVIDED HARDWARE MAY DAMAGE THE INTAKE TUBE, THROTTLE BODY AND ENGINE.

TO START:

1. Turn off the ignition and disconnect the negative battery cable.

NOTE: Disconnecting the negative battery cable erases pre-programmed electronic memories. Write down all memory settings before disconnecting the negative battery cable. Some radios will require an anti-theft code to be entered after the battery is reconnected. The anti-theft code is typically supplied with your owner's manual. In the event your vehicles' anti-theft code cannot be recovered, contact an authorized dealership to obtain your vehicles anti-theft code.



2. Remove the two fasteners which retain the fresh air inlet scoop and then remove the fresh air inlet scoop from the vehicle as shown.



3. Disconnect the mass air sensor electrical connection and then unhook the wiring harness from the airbox.



4. Loosen the two hose clamps which secure the factory intake tube and then remove the intake tube from the vehicle.



5. Loosen and remove the two bolts which secure the airbox to the inner fender.



6. Remove the airbox assembly from the vehicle.
NOTE: K&N Engineering, Inc., recommends that customers do not discard factory air intake.



7. Install the two rubber mounted studs into the inner fender as shown.

NOTE: Due to vehicle manufacturing differences, the front rubber mounted stud may not be used on some models.



8. Remove the two screws which secure the mass air sensor and then remove the mass air sensor from the airbox as shown.



9. Install the mass air sensor into the K&N® intake tube and secure with the provided hardware.

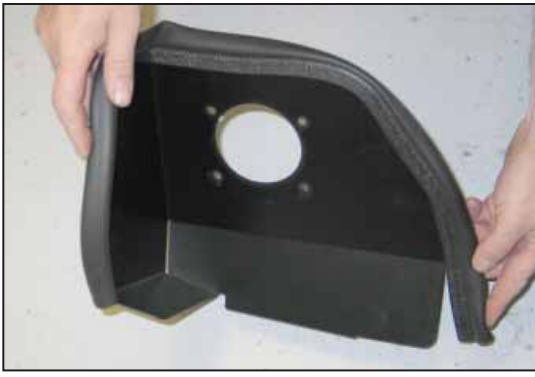

10. Install the provided edge trim onto the heat shield as shown.

NOTE: Some trimming of the edge trim will be necessary.



11. Install the four 6mm studs into the filter adapter as shown.



12. Install the filter adapter gasket onto the four studs as shown.



13. Install the filter adapter assembly into the heat shield and then install the remaining gasket onto the studs protruding through the heat shield as shown.



14. Install the K&N® intake tube onto the studs and secure with the provided nuts and washers.



15. Install the K&N® air filter onto intake assembly and secure with the provided hose clamp.



16. Install the provided silicone hose (08440) onto the intake tube as shown.

NOTE: Slide the hose all the way onto the tube to expose the end of the tube so to ease kit installation.



17. Install the K&N® intake kit so that the heat shield rests on the rubber mounted studs installed during step #7. Secure the heat shield with the provided hardware. Slide the silicone hose onto the turbo inlet and secure with the provided hose clamp.



18. Reconnect the mass air sensor electrical connection as shown.



19. Reconnect the vehicle's negative battery cable. Double check to make sure everything is tight and properly positioned before starting the vehicle.

20. The C.A.R.B. exemption sticker, (attached), must be visible under the hood so that an emissions inspector can see it when the vehicle is required to be tested for emissions. California requires testing every two years, other states may vary.

21. It will be necessary for all K&N® high flow intake systems to be checked periodically for realignment, clearance and tightening of all connections. Failure to follow the above instructions or proper maintenance may void warranty.

ROAD TESTING:

1. Start the engine with the transmission in neutral or park, and the parking brake engaged. Listen for air leaks or odd noises. For air leaks secure hoses and connections. For odd noises, find cause and repair before proceeding. This kit will function identically to the factory system except for being louder and much more responsive.

2. Test drive the vehicle. Listen for odd noises or rattles and fix as necessary.

3. If road test is fine, you can now enjoy the added power and performance from your kit.

4. K&N Engineering, Inc., suggests checking the air filter element periodically for excessive dirt build-up. When the element becomes covered in dirt (or once a year), service it according to the instructions on the Recharger® service kit, part number 99-5050 or 99-5000.

STREET LEGAL IN MOST STATES

**NOT LEGAL FOR USE IN CA & OTHER STATES
ADOPTING CA EMISSIONS STANDARDS**

See our catalog or knfilters.com for CARB status on each part for a specific vehicle

* FREE K&N® decal To register your warranty, please see us online at knfilters.com/register. FREE K&N® decal *