



TYPHOON INTAKE SYSTEMS

INSTALLATION INSTRUCTIONS

69-6545

MITSUBISHI

2006 Lancer Evolution

IX L4-2.0L Turbo

TOOLS NEEDED:

- 4mm Allen Wrench
- 10MM Socket
- 10MM Wrench
- 12mm Wrench
- Extension
- Flat blade Screwdriver
- Phillips Screwdriver
- Pliers
- Ratchet

PARTS LIST:

Description	Qty.	Part #
A Air Filter	1	RP-4600
B Hose Clamp #104	1	08697
C Edge Trim (9")	1	102465
D Edge Rim (18")	1	102504
E Heat Shield	1	074045
F Bolt; M6 x 1.00 x 16MM , ButtnHd., SS	3	07730
G Washer; 1/4"ID x 5/8"OD - SAE	10	08275
H Clip; Air-Scoop, Stl., Blk.	2	27912
I Bracket; "L", Stl, FB/PC	1	070102
J Nut; 6MM Nylock, Hex Head, SS	3	07512
K Adaptor; Nylon Black, #390	1	088010
L Washer; 1/4" Lock, ZN	4	08198
M Bracket; "Z", Stl., TK/PC	2	010033
N Bolt; M6-1.00 x 25MM ButtnHd., SS	4	07729

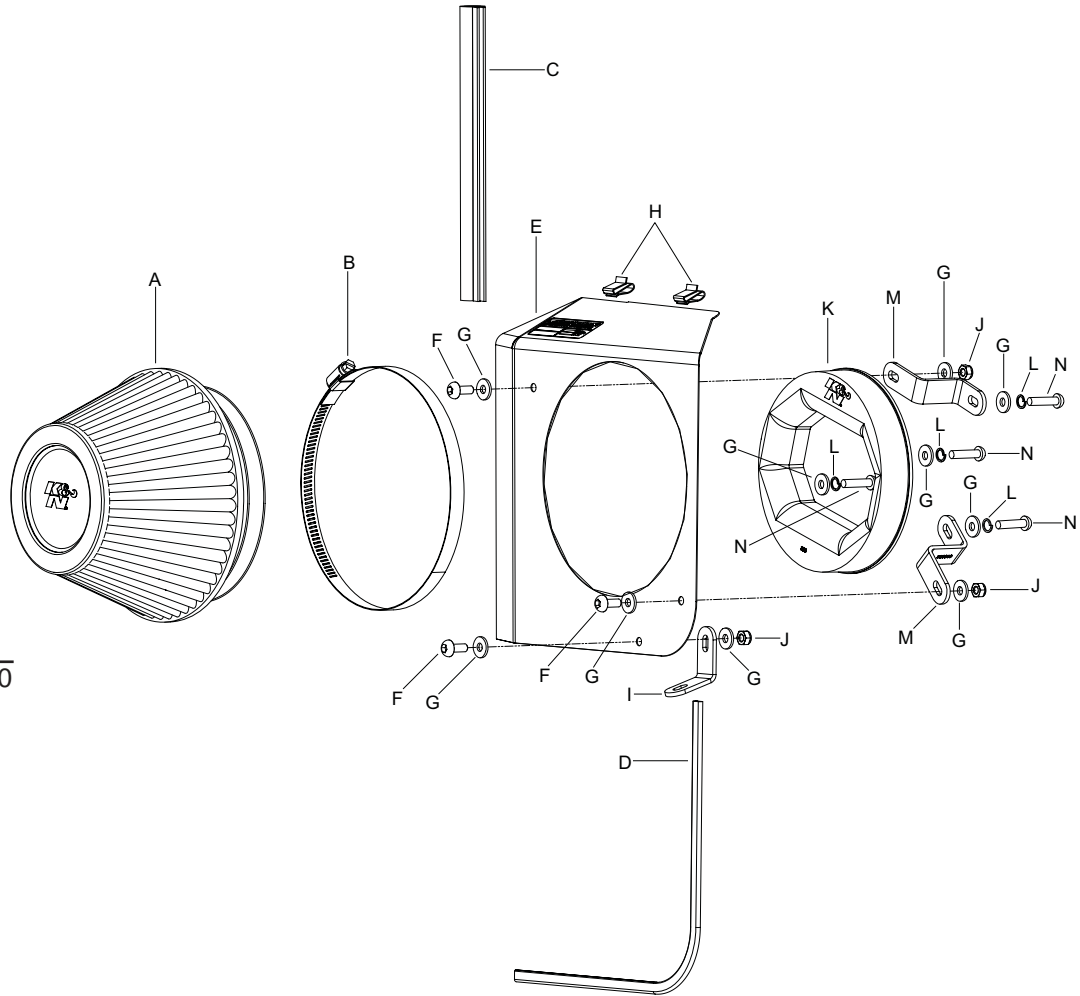

NOTE: FAILURE TO FOLLOW INSTALLATION INSTRUCTIONS AND NOT USING THE PROVIDED HARDWARE MAY DAMAGE THE INTAKE TUBE, THROTTLE BODY AND ENGINE.

TO START:

1. Turn off the ignition and disconnect the negative battery cable.

NOTE: Disconnecting the negative battery cable erases pre-programmed electronic memories. Write down all memory settings before disconnecting the negative battery cable. Some radios will require an anti-theft code to be entered after the battery is reconnected. The anti-theft code is typically supplied with your owner's manual. In the event your vehicles' anti-theft code cannot be recovered, contact an authorized dealership to obtain your vehicles anti-theft code.



2. Loosen the plastic screws shown which retain the fresh air supply duct.



3. Unclip the four upper airbox retaining clips; then remove the upper airbox and fresh air duct assembly as shown.



4. Remove the two airbox mounting bolts shown. Then loosen the hose clamp which secures the intake tube to the mass air sensor.



5. Lift the mass air sensor/airbox assembly up, disconnect the mass air sensor electrical connection and unhook the wiring harness from the airbox. Then remove the complete assembly as shown. **NOTE: K&N Engineering, Inc., recommends that customers do not discard factory air intake.**



6. Remove the two solenoid valve mounting bolts shown. **NOTE: These bolts will be reused in a later step.**



7. Remove the airbox mounting bracket bolt and intercooler mounting bolt shown. Unhook the wiring harness from the airbox mounting bracket; then remove the mounting bracket from the vehicle. **NOTE: The airbox mounting bracket bolt will be reused in a later step.**



8. Reinstall the solenoid valve in its original location and secure with the factory bolts removed during step #6.

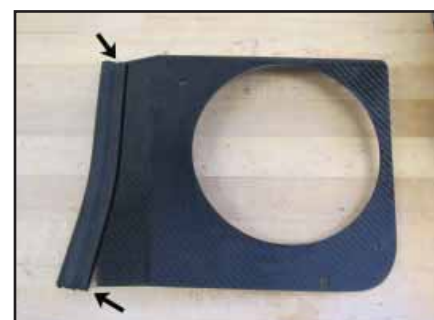

9. Install the provided edge trim onto the heat shield as shown. **NOTE: Some trimming of the edge trim may be necessary.**

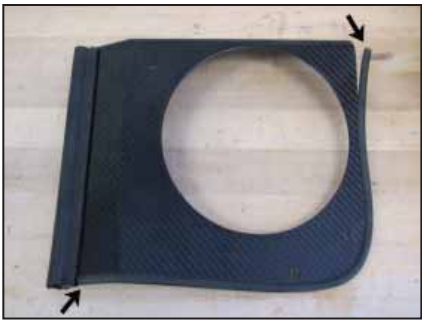

10. Install the provided edge trim onto the heat shield as shown.

NOTE: Some trimming of the edge trim may be necessary.



11. Install the provided heat shield mounting bracket (070102) onto the heat shield using the provided hardware.

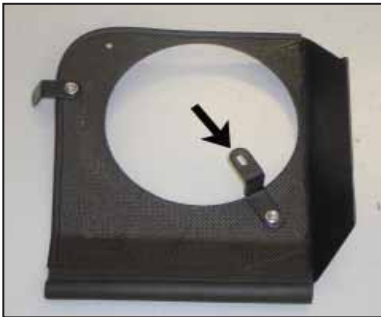

12. Install one of the supplied mass air sensor mounting brackets (010033) onto the heat shield as shown.



13. Install the remaining mass air sensor mounting bracket (010033) onto the heat shield as shown.



14. Remove the four mass air sensor mounting bolts; then remove the mass air sensor as shown.

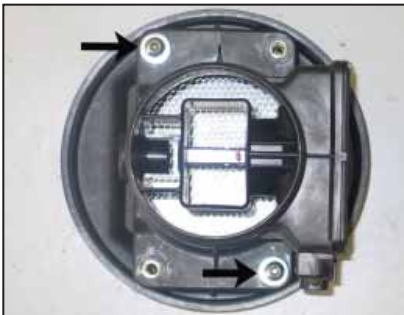

15. Secure the filter adapter to the mass air sensor using two of the supplied bolts where shown.

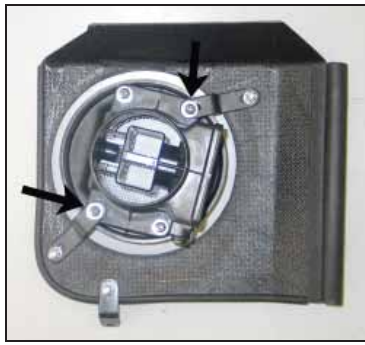

16. Secure the heat shield assembly to the mass air sensor using the supplied hardware.



17. Install the K&N® air filter onto the filter adapter and secure with the provided hardware.



18. Disconnect the solenoid valve electrical connection and reroute the mass air sensor/solenoid valve wiring harness under the main wiring harness as shown. Reconnect the solenoid valve wiring connection.



19. Install the mass air sensor/filter assembly into the into the factory intake tube and secure with the factory hose clamp.

NOTE: As the assembly is being installed, reconnect the mass air sensor electrical connection. Secure the lower heat shield mounting bracket to the inner fender using the factory bolt removed in step #7.



20. Remove the fresh air duct from the upper air-box housing.



21. Install the two provided clips onto the fresh air supply duct as shown.



22. Clip the fresh air supply duct onto the heat shield and secure the front with the factory plastic screw.



23. Reconnect the vehicle's negative battery cable. Double check to make sure everything is tight and properly positioned before starting the vehicle.

24. The C.A.R.B. exemption sticker, (attached), must be visible under the hood so that an emissions inspector can see it when the vehicle is required to be tested for emissions. California requires testing every two years, other states may vary.

25. It will be necessary for all K&N® high flow intake systems to be checked periodically for realignment, clearance and tightening of all connections. Failure to follow the above instructions or proper maintenance may void warranty.

ROAD TESTING:

1. Start the engine with the transmission in neutral or park, and the parking brake engaged. Listen for air leaks or odd noises. For air leaks secure hoses and connections. For odd noises, find cause and repair before proceeding. This kit will function identically to the factory system except for being louder and much more responsive.

2. Test drive the vehicle. Listen for odd noises or rattles and fix as necessary.

3. If road test is fine, you can now enjoy the added power and performance from your kit.

4. K&N Engineering, Inc., suggests checking the air filter element periodically for excessive dirt build-up. When the element becomes covered in dirt (or once a year), service it according to the instructions on the Recharger® service kit, part number 99-5050 or 99-5000.

50-STATE STREET LEGAL
K&N CARB EXEMPT K&N

* FREE K&N® decal To register your warranty, please see us online at knfilters.com/register. FREE K&N® decal *