



TYPHOON INTAKE SYSTEMS



INSTALLATION INSTRUCTIONS

**69-5306
KIA
2010-11 Soul
L4-2.0L**

TOOLS NEEDED:

- Flat blade screw driver
- Phillips screw driver
- Ratchet, Extension
- 13mm socket
- 12mm socket
- 10mm socket
- Pliers
- 4mm allen wrench

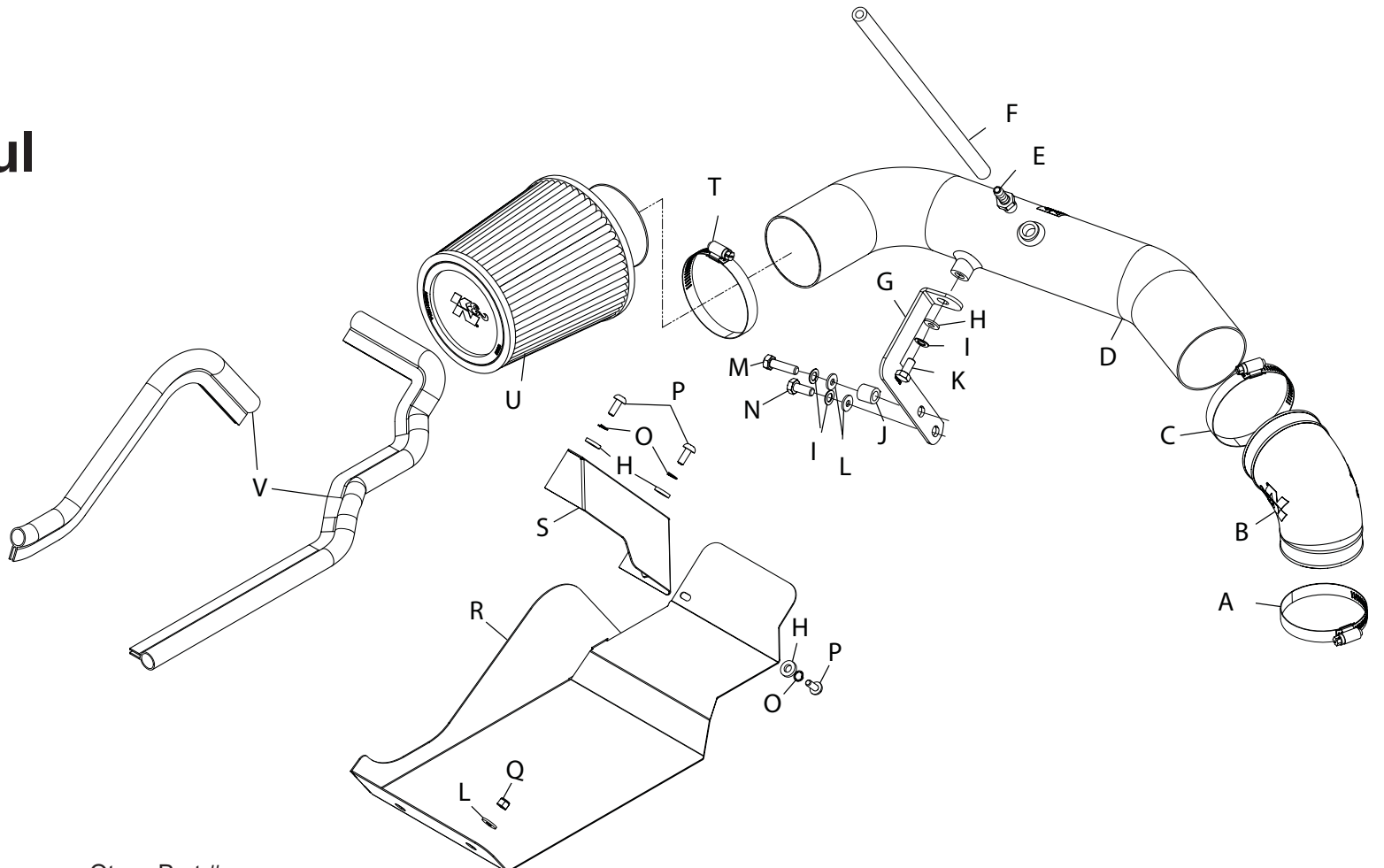

PARTS LIST:

Description	Qty.	Part #	Description	Qty.	Part #	Description	Qty.	Part #
A Hose Clamp #48	1	08601	I Washer 8MM Spring(wave)	3	08239	Q Nut; 6mm nylock, hexhead, ss	1	07512
B Hose; 3"TO 2-3/4" id 98° angled	1	084087	J Spacer; .625"odX.375" idX.625"L,ZN	1	07849	R Heat shield	1	074065
C Hose Clamp #44 Stainless	1	08560	K Bolt; 8mm-1.25X16mm, hexhead	1	07844	S Heat shield; duct	1	074064
D Intake tube	1	27470	L Washer; 5/16" idX5/8" od, flat	3	08276	T Hose Clamp #52	1	08610
E Vent; strt, 5/16" barbed, 1/4 npt	1	08908	M Bolt; m8-1.0X20mm, tap	1	06533	U Air Filter	1	RU-4990
F Hose; 8mm idX15-1/2"l	1	08105	N Bolt; 8mm-1.25X30mm, hexhead	1	07821	V Edge trim (39")	1	102496
G Bracket; "L" stl. tk/pc	1	083134	O Washer; 1/4" lock, zn	3	08198			
H Washer; 1/4" idX5/8" od - sae	4	08275	P Bolt; m6X1.00X16mm, bttnd, ss	3	07730			

NOTE: FAILURE TO FOLLOW INSTALLATION INSTRUCTIONS AND NOT USING THE PROVIDED HARDWARE MAY DAMAGE THE INTAKE TUBE, THROTTLE BODY AND ENGINE.

TO START:

1. Turn off the ignition and disconnect the negative battery cable.
NOTE: Disconnecting the negative battery cable erases pre-programmed electronic memories. Write down all memory settings before disconnecting the negative battery cable. Some radios will require an anti-theft code to be entered after the battery is reconnected. The anti-theft code is typically supplied with your owner's manual. In the event your vehicles' anti-theft code cannot be recovered, contact an authorized dealership to obtain your vehicles anti-theft code.



2. Release the spring clamp which secures the crank case vent hose to the valve cover and then unhook the crank case vent hose from valve cover and disconnect the ISC motor wiring harness from the retaining clip attached to the crank case vent hose.



3. Loosen the hose clamps which secure the stock intake tube to the throttle body and air filter housing.



4. Remove the stock intake tube from the vehicle.



5. Release the upper air box retaining clips and then remove the upper air box from the vehicle.



6. Remove the three air box mounting bolts and the two plastic fresh air scoop retaining screws shown.



7. Remove the lower air box housing from the vehicle.

NOTE: K&N Engineering, Inc., recommends that customers do not discard factory air intake.

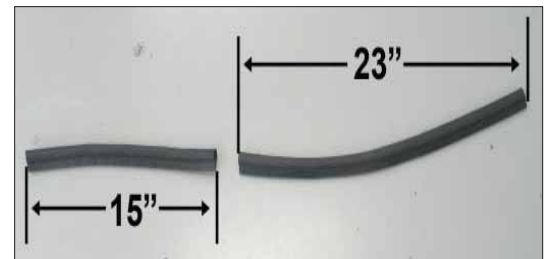

8. Cut the provided edge trim into two lengths, one length of 15" and one length of 23".



9. Install the 23" long piece of edge trim onto the heat shield as shown.

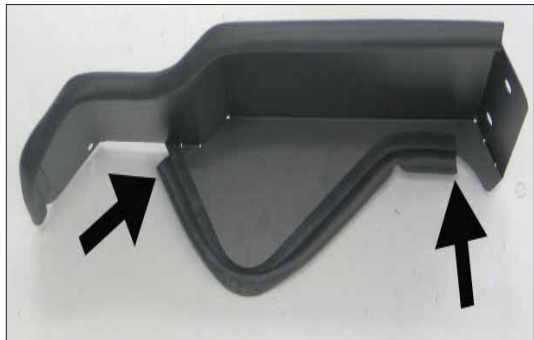

10. Install the 15" long piece of edge trim onto the heat shield as shown.

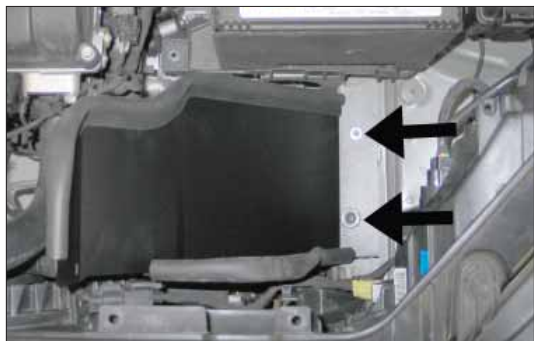

11. Install the heat shield onto the frame rail and secure to the factory stud with the provided hardware and one of the factory air box mounting bolts. **NOTE: Do not completely tighten at this time.**



12. Secure the K&N fresh air scoop to the core support and heat shield using the provided hardware.



13. Remove the wiring harness retaining bracket bolt shown.



14. Install the K&N tube mounting bracket (083134) onto the cylinder head and secure with the provided hardware. **NOTE: be sure to place the provided spacer between the wiring harness bracket and the tube mounting bracket.**



15. Install the provided silicone hose (084087) onto the throttle body and secure with the provided hose clamp.



16. Install the provided 1/4npt fitting into the K&N intake tube as shown.



17. Set the K&N air filter into position at the bottom of the heat shield as shown.



18. Install the K&N intake tube into the silicone hose at the throttle body and align with the tube mounting bracket. Secure the intake tube with the hose clamp and hardware provided.



19. Install the provided crank case vent hose onto the 1/4npt fitting in the K&N intake tube and then attach the open end to the vent port on the valve cover.



20. Install the K&N air filter onto the intake tube and secure with the provided hose clamp.



21. Reconnect the vehicle's negative battery cable. Double check to make sure everything is tight and properly positioned before starting the vehicle.
22. It will be necessary for all K&N® high flow intake systems to be checked periodically for realignment, clearance and tightening of all connections. Failure to follow the above instructions or proper maintenance may void warranty.

ROAD TESTING:

1. Start the engine with the transmission in neutral or park, and the parking brake engaged. Listen for air leaks or odd noises. For air leaks secure hoses and connections. For odd noises, find cause and repair before proceeding. This kit will function identically to the factory system except for being louder and much more responsive.
2. Test drive the vehicle. Listen for odd noises or rattles and fix as necessary.
3. If road test is fine, you can now enjoy the added power and performance from your kit.
4. K&N Engineering, Inc., suggests checking the air filter element periodically for excessive dirt build-up. When the element becomes covered in dirt (or once a year), service it according to the instructions on the Recharger® service kit, part number 99-5050 or 99-5000

STREET LEGAL IN MOST STATES

**NOT LEGAL FOR USE IN CA & OTHER STATES
ADOPTING CA EMISSIONS STANDARDS**

See our catalog or knfilters.com for CARB status on each part for a specific vehicle

* FREE K&N® decal To register your warranty, please see us online at knfilters.com/register. FREE K&N® decal *

• 1455 CITRUS ST., P.O. BOX 1329, RIVERSIDE, CA., U.S.A. 92502 • TECH SERVICE 800-858-3333 • FAX 951-826-4001
• e-mail: tech@knfilters.com • WWW: <http://www.knfilters.com>