

TYPHOON INTAKE SYSTEMS



INSTALLATION INSTRUCTIONS

69-2541

Chrysler

2003-08 PT Cruiser GT

L4-2.4L Turbo

NOTE: C.A.R.B. E.O.# D-269-30 applies to 2003-2004 model years ONLY

TOOLS NEEDED:

Ratchet
12" extension
5/16" socket
13mm wrench

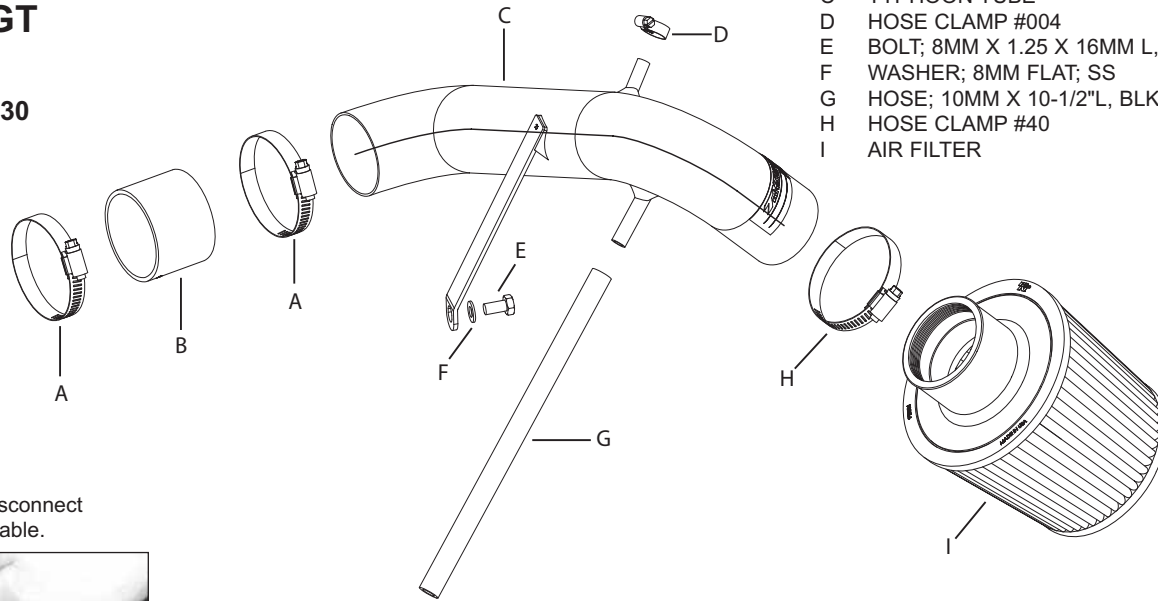

Parts List

Description	Qty.	P/N
A HOSE CLAMP #44, SS	2	08560
B HOSE; 2-1/2"ID X 2"L, BLACK	1	08284
C TYPHOON TUBE	1	27149
D HOSE CLAMP #004	1	21850
E BOLT; 8MM X 1.25 X 16MM L, HEX, SS	1	077002
F WASHER; 8MM FLAT; SS	1	08272
G HOSE; 10MM X 10-1/2"L, BLK SILICONE	1	08102
H HOSE CLAMP #40	1	08554
I AIR FILTER	1	KRU4950E

NOTE: FAILURE TO FOLLOW INSTALLATION INSTRUCTIONS AND NOT USING THE PROVIDED HARDWARE MAY DAMAGE THE INTAKE TUBE, THROTTLE BODY, AND ENGINE.

TO START:

1. Turn the ignition OFF and disconnect the vehicle's negative battery cable.



2. Loosen the hose clamp at the turbocharger inlet as shown.



3. Disconnect the stock vent hose as shown.



4. Unclip the upper air cleaner lid, then, remove the upper air cleaner assembly as shown.

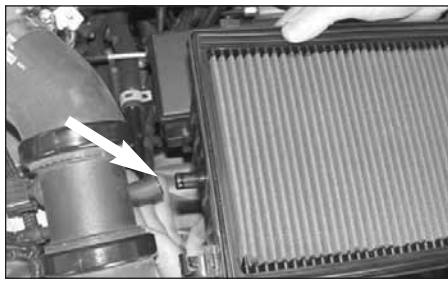

5. Pull firmly upward to release the lower air cleaner assembly, then disconnect the crank case vent hose as shown.



6. Remove the lower air cleaner assembly as shown.

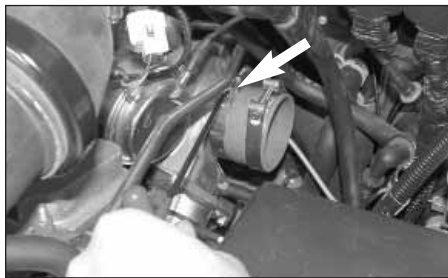

7. Install the silicone hose and hose clamps onto the turbocharger inlet and tighten as shown.

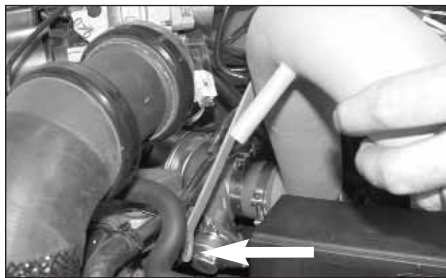

8. Slide the intake tube into the silicone hose as shown.

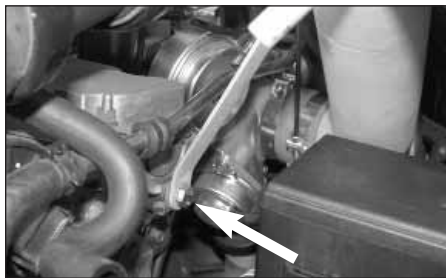

9. Line up the bracket with the threaded boss on the cylinder head and secure with the provided hex bolt.



10. Tighten the hose clamp on the intake tube as shown.

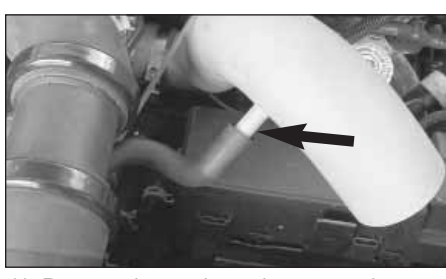

11. Remove the stock crankcase vent hose and using the supplied 10-1/2" silicone hose, measure and cut 2" off of one end of the hose and set it aside. Connect the 8-1/2" hose to the crankcase vent tube and the other end to the vent on the intake tube as shown.



12. Slide the 2" silicone hose and hose clamp onto the vent on the short ram tube and tighten as shown.



13. Reconnect the stock vent hose to the short ram tube as shown.



14. Install the K&N air filter onto the intake tube and secure with the provided hose clamp as shown.



15. Reconnect the negative battery cable, then double check to make sure everything is tight and properly positioned before starting the vehicle.

16. The C.A.R.B. exemption sticker, (attached), must be visible under the hood, so that an emissions inspector can see it when the vehicle is required to be tested for emissions. California requires testing every two years, other states may vary.

17. It will be necessary for all Typhoon's to be checked periodically for realignment, clearance and tightening of all connections. Failure to follow the above instructions or proper maintenance may void warranty.

ROAD TESTING:

1. Start the engine with the transmission in neutral or park, and the parking brake engaged. Listen for air leaks or odd noises. For air leaks secure hoses and connections. For odd noises, find cause and repair before proceeding. This kit will function identically to the factory system except for being louder and much more responsive.
2. Test drive the vehicle. Listen for odd noises or rattles and fix as necessary.
3. If road test is fine, you can now enjoy the added power and performance from your kit.
4. K&N suggests checking the air filter element periodically for excessive dirt build-up. When the element becomes covered in dirt (or once a year), service it according to the instructions on the Recharger service kit, part number 99-5000 or 99-5050.

FREE K&N DECAL To register your warranty, please see us online at knfilters.com/register. FREE K&N DECAL