



TYPHOON INTAKE SYSTEMS



INSTALLATION INSTRUCTIONS

**69-2005
MINI
2007-11 Cooper
L4-1.6L**

TOOLS NEEDED:

- Ratchet
- Extension
- 10mm socket
- Flat blade screw driver
- Pliers
- 10mm wrench
- T25 TORX
- T30 TORX
- 5/32 allen wrench

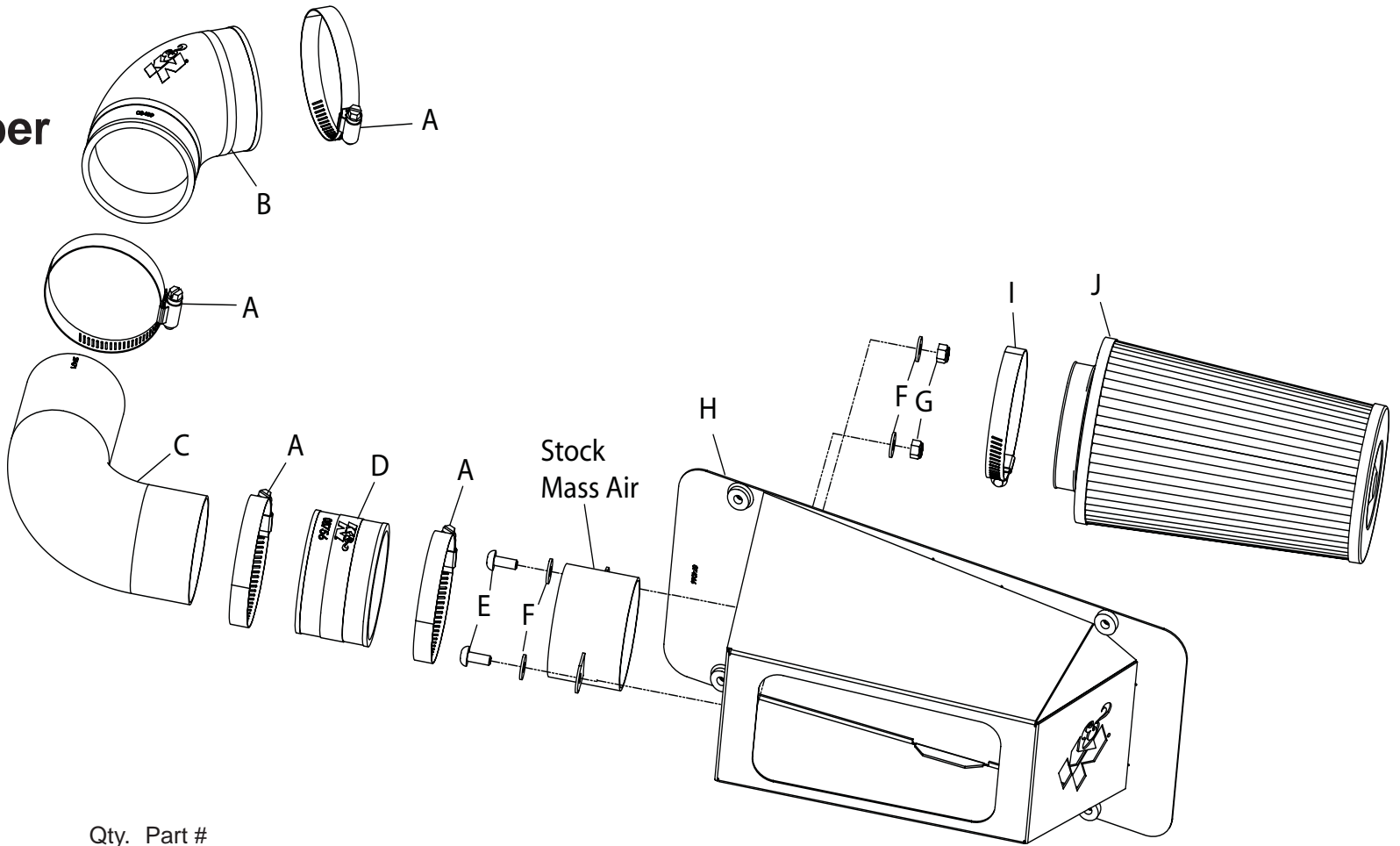

PARTS LIST:

Description	Qty.	Part #	Description	Qty.	Part #	Description	Qty.	Part #
A Hose Clamp #44 Stainless	4	08560	E Bolt; M6 X 1.00 X 16MM btnhd	2	07730	I Hose Clamp #44	1	08577
B Hose; 2.75" ID Angled 30deg,	1	08489	F Washer; 6MM Flat, SS	4	08269	J Air Filter	1	RC-5144
C Intake tube	1	27471	G Nut; 6MM Nylock, Hexhead, SS	2	07512			
D Hose; 2-3/4" ID X 2" L	1	08756	H Heat shield	1	074066			

NOTE: FAILURE TO FOLLOW INSTALLATION INSTRUCTIONS AND NOT USING THE PROVIDED HARDWARE MAY DAMAGE THE INTAKE TUBE, THROTTLE BODY AND ENGINE.

TO START:

1. Turn off the ignition and disconnect the negative battery cable.

NOTE: Disconnecting the negative battery cable erases pre-programmed electronic memories. Write down all memory settings before disconnecting the negative battery cable. Some radios will require an anti-theft code to be entered after the battery is reconnected. The anti-theft code is typically supplied with your owner's manual. In the event your vehicles' anti-theft code cannot be recovered, contact an authorized dealership to obtain your vehicles anti-theft code.



2. Release the locking tab and then disconnect the mass air sensor electrical connection.



3. Loosen the hose clamp which secures the intake tube to the mass air sensor.



4. Loosen the four screws which secure the upper air box housing to the lower air box housing.



5. Loosen the bolt which secures the upper air box to the valve cover.



6. Remove the upper air box from the vehicle as shown and then remove the stock air filter.



7. Loosen the hose clamp which secures the stock intake hose and then remove the stock intake hose from the vehicle.

NOTE: K&N Engineering, Inc., recommends that customers do not discard factory air intake.



8. Remove the two screws which secure the mass air sensor to the upper air box and then remove the mass air sensor.



9. Remove the "O" ring from the mass air sensor as shown.



10. Remove the four upper air box retaining screws from the upper air box.

NOTE: The four upper air box mounting screws will be reused.



11. Using the provided hardware, secure the factory mass air sensor to the K&N heat shield as shown.



12. Install the K&N air filter onto the mass air sensor and secure with the provided hose clamp.



13. Secure the provided silicone hose (08489) onto the throttle body and secure with the provided hose clamp.



14. Install the heat shield/filter assembly onto the lower air box and secure with the four factory upper air box retaining screws.



15. Install the provided silicone hose (08756) onto the mass air sensor and secure with the provided hose clamp.



16. Install the K&N intake tube into the silicone hoses and secure with the provided hose clamps.



17. Reconnect the mass air sensor electrical connection.



18. Reconnect the vehicle's negative battery cable. Double check to make sure everything is tight and properly positioned before starting the vehicle.

19. It will be necessary for all K&N® high flow intake systems to be checked periodically for realignment, clearance and tightening of all connections. Failure to follow the above instructions or proper maintenance may void warranty.

ROAD TESTING:

1. Start the engine with the transmission in neutral or park, and the parking brake engaged. Listen for air leaks or odd noises. For air leaks secure hoses and connections. For odd noises, find cause and repair before proceeding. This kit will function identically to the factory system except for being louder and much more responsive.

2. Test drive the vehicle. Listen for odd noises or rattles and fix as necessary.

3. If road test is fine, you can now enjoy the added power and performance from your kit.

4. K&N Engineering, Inc., suggests checking the air filter element periodically for excessive dirt build-up. When the element becomes covered in dirt (or once a year), service it according to the instructions on the Recharger® service kit, part number 99-5050 or 99-5000

STREET LEGAL IN MOST STATES

**NOT LEGAL FOR USE IN CA & OTHER STATES
ADOPTING CA EMISSIONS STANDARDS**

See our catalog or knfilters.com for CARB status on each part for a specific vehicle

* FREE K&N® decal To register your warranty, please see us online at knfilters.com/register. FREE K&N® decal *

• 1455 CITRUS ST., P.O. BOX 1329, RIVERSIDE, CA., U.S.A. 92502 • TECH SERVICE 800-858-3333 • FAX 951-826-4001
• e-mail: tech@knfilters.com • WWW: <http://www.knfilters.com>