



# TYPHOON INTAKE SYSTEMS



## INSTALLATION INSTRUCTIONS

**69-1210**  
**ACURA / HONDA**  
**2010 TL**  
**V6-3.7L**  
**2007-10 TL**  
**2010-11 Accord Crosstour**  
**2008-11 Accord**  
**V6-3.5L**

NOTE: C.A.R.B E.O. # D-269-37 Applies ONLY to 2008-10 Accord and 2010 Accord Crosstour Model Year Vehicles

### TOOLS NEEDED:

- 5/8" Wrench
- 3mm Allen Wrench
- 10mm Socket
- 10mm Wrench
- 12mm Wrench
- Extension
- Flat Blade Screwdriver
- Phillips Screwdriver
- Pliers
- Ratchet

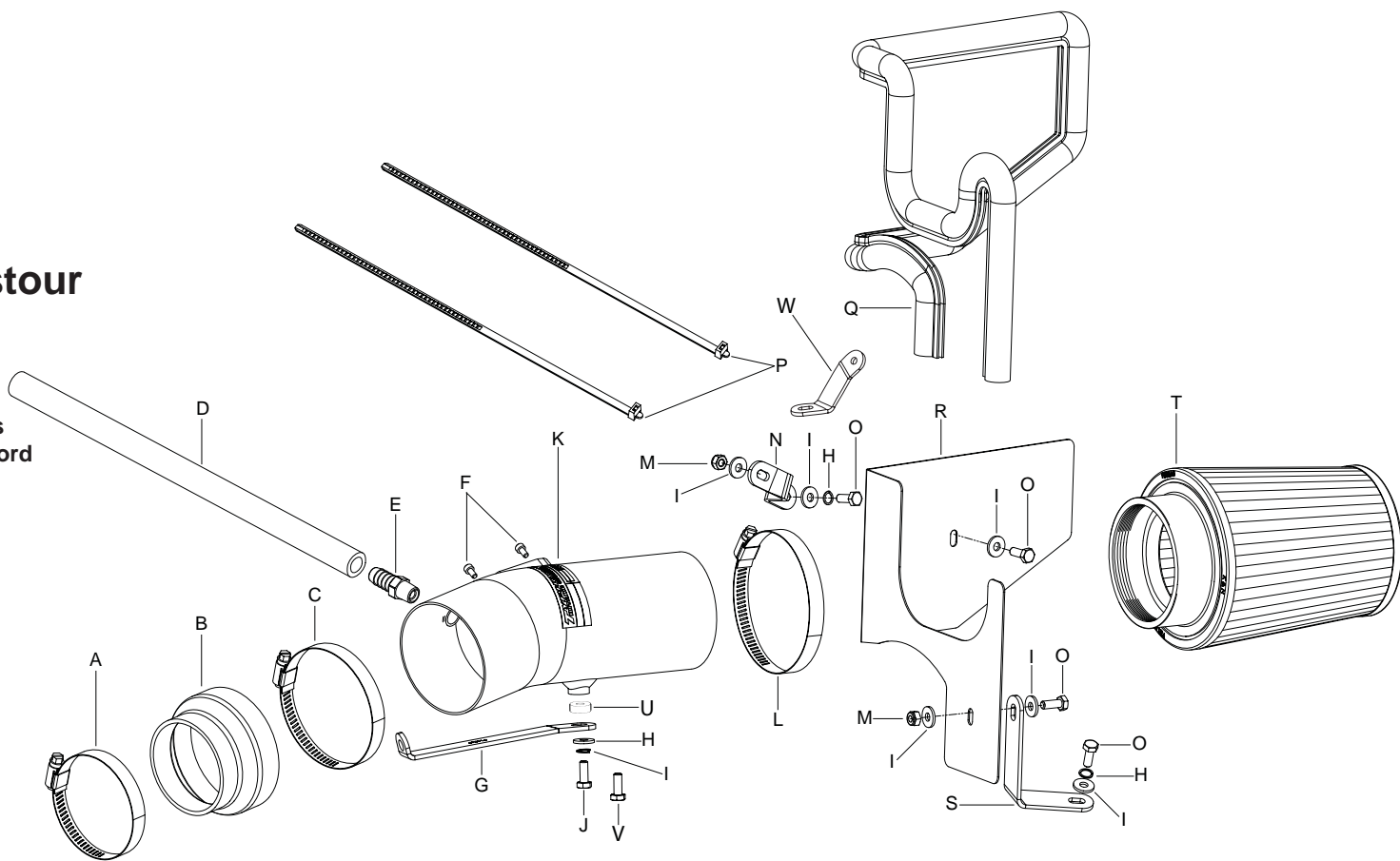

### PARTS LIST

Description	Qty.	Part #	Description	Qty.	Part #	Description	Qty.	Part #
A Hose Clamp #44	1	08560	I Washer; 1/4"ID x 5/8"OD-SAE	7	08275	Q Edge Trim (48")	1	102485
B Hose; 3.5" To 2.75" X 2"L	1	084093	J Bolt; M6 X 1.00" x 20mm Hex,	1	07795	R Heat Shield	1	073101
C Hose Clamp #52	1	08610	K Intake Tube	1	27193	S Bracket; "L", Stl., FB/PC	1	070115
D Hose; 1/2"ID X 14"L	1	08402	L Hose Clamp #60	1	08624	T Air Filter	1	RC-4630
E Vent; Strt. 1/2" Hose, 1/4"NPT,	1	080022	M Nut; 6mm Nylock, Hex Head	2	07512	U Spacer: .625"OD X .250"ID X .250"L	1	06555
F Bolt; M4 - 0.07 8mm, A/H CAP,	2	07733	N Bracket; "Z", Stl., FB/PC	1	070116	V Bolt; M6-1.00 X 25mm, SS	1	07858
G Bracket; "L", Stl., FB/PC	1	070114	O Bolt; 6mm-1.00 x 16mm	4	07812	W Bracket; "Z", Stl, TK/PC	1	083158
H Washer; 1/4" Lock, ZN	3	08198	P Cable Ties; 11"	2	21590			

**NOTE: FAILURE TO FOLLOW INSTALLATION INSTRUCTIONS AND NOT USING THE PROVIDED HARDWARE MAY DAMAGE THE INTAKE TUBE, THROTTLE BODY AND ENGINE.**

### TO START:



1. Turn off the ignition and disconnect the negative battery cable.

**NOTE: Disconnecting the negative battery cable erases pre-programmed electronic memories. Write down all memory settings before disconnecting the negative battery cable. Some radios will require an anti-theft code to be entered after the battery is reconnected. The anti-theft code is typically supplied with your owner's manual. In the event your vehicles' anti-theft code cannot be recovered, contact an authorized dealership to obtain your vehicles anti-theft code.**



2. Disconnect the positive battery cable, remove the battery hold down and then remove the battery.



3. Disconnect the mass air sensor electrical connection.



4. Disconnect the crankcase vent tube from the intake tube and valve cover port as shown. The spring clamps will not be reused.  
**NOTE: Acura vehicles have a side and front engine cover that will need to be removed before performing this step.**



5. Loosen the hose clamp which secures the stock intake tube to the throttle body.



6. Loosen the bolt which secures the lower airbox to the battery tray.



7. Remove the airbox assembly from the vehicle; be sure to unhook the wiring harness from the airbox as it is removed.  
**NOTE: K&N Engineering, Inc., recommends that customers do not discard factory air intake.**



8. Remove the front lower throttle body bolt shown.  
**NOTE: This bolt will be reused in the next step.**



9. Install the tube mounting bracket (070114) onto the throttle body and secure with the bolt removed in the previous step.



10. On Honda vehicles, remove the airbox mounting bracket bolt shown.



10a. On Acura vehicles, remove the bolt shown that secures the wiring harness mounting bracket to the strut tower.



11. On Honda vehicles, install the heat shield mounting bracket (070116) onto the air box mounting bracket and secure with the provided hardware.



11a. On Acura vehicles Install the heat shield mounting bracket (083158) onto the strut tower and secure with the provided hardware.



12. Install the heat shield mounting bracket (070115) onto the airbox mounting location on the battery tray using the provided hardware.



13. Install the provided edge trim onto the heat shield as shown.  
**NOTE: Some trimming of the edge trim will be necessary.**



14. Install the heat shield assembly into the vehicle and secure to the mounting brackets with the hardware provided.



15. Install the silicone hose (084093) onto the throttle body and secure with the provided hose clamp.



16. Install the 1/4" NPT fitting into the K&N® intake tube as shown.



17. Remove the mass air sensor from the stock airbox.



18. Install the mass air sensor into the K&N® intake tube and secure with the provided hardware.



19. Install the K&N® intake tube into the silicone hose at the throttle body and align with the mounting bracket. Secure with the hose clamp and provided hardware.

**NOTE: On Acura vehicles, install the provided spacer in-between the mounting bracket and tube, then secure with the longer 6mm bolt provided.**



20. Install the provided crankcase vent hose onto the NPT fitting and then onto the valve cover port. Secure the crankcase hard line to the provided hose with the tie wraps provided.



21. Install the K&N® air filter onto the intake tube and secure with the provided hose clamp.



22. Reinstall the battery and secure with the hold down bracket. Reconnect the positive battery cable.



23. Reconnect the mass air sensor electrical connection.



24. Reconnect the vehicle's negative battery cable. Double check to make sure everything is tight and properly positioned before starting the vehicle.

25. The C.A.R.B. exemption sticker, (attached), must be visible under the hood so that an emissions inspector can see it when the vehicle is required to be tested for emissions. California requires testing every two years, other states may vary.

26. It will be necessary for all K&N® high flow intake systems to be checked periodically for realignment, clearance and tightening of all connections. Failure to follow the above instructions or proper maintenance may void warranty.

#### ROAD TESTING:

1. Start the engine with the transmission in neutral or park, and the parking brake engaged. Listen for air leaks or odd noises. For air leaks secure hoses and connections. For odd noises, find cause and repair before proceeding. This kit will function identically to the factory system except for being louder and much more responsive.

2. Test drive the vehicle. Listen for odd noises or rattles and fix as necessary.

3. If road test is fine, you can now enjoy the added power and performance from your kit.

4. K&N Engineering, Inc., requires cleaning the intake system's air filter element every 100,000 miles. When used in dusty or off-road environments, our filters will require cleaning more often. We recommend that you visually inspect your filter once every 25,000 miles to determine if the screen is still visible. When the screen is no longer visible some place on the filter element, it is time to clean it. To clean and re-oil, purchase our filter Recharger® service kit, part number 99-5050 or 99-5000 and follow the easy instructions.

**STREET LEGAL IN MOST STATES**

**NOT LEGAL FOR USE IN CA & OTHER STATES  
ADOPTING CA EMISSIONS STANDARDS**

**See our catalog or [knfilters.com](http://knfilters.com) for CARB status on each part for a specific vehicle**

\* FREE K&N® decal To register your warranty, please see us online at [knfilters.com/register](http://knfilters.com/register). FREE K&N® decal \*