



TYPHOON INTAKE SYSTEMS



INSTALLATION INSTRUCTIONS

69-1007
HONDA
2000-05 Civic
L4-1.6L
2000-04 Civic
L4-1.4L
2001-04 Civic
Manual Trans. Only
L4-1.7L

NOTE: C.A.R.B. E.O.# D-269-30 Applies ONLY to 2001-2004 Model Year Vehicles

TOOLS NEEDED:

- Flat Blade Screwdriver
- Ratchet
- 3" Extension
- 6" Extension
- 14" Extension
- 8mm Socket
- 10mm Socket
- Pliers
- 4mm Allen Wrench

PARTS LIST:

Description	Qty.	Part #	Description	Qty.	Part #	Description	Qty.	Part #
A Drycharger®, Black	1	RX-4990DK	E Flat washer	2	08269	I Hose, Black	2	08284
B Air Filter	1	RU-4950	F 6mm Nylock Nut	2	07512	J Grommet, 5/8" ID	1	08283
C Hose clamp, #40	1	08554	G Intake Tube	1	087037	K Hose, 5/8"ID x 5"L	1	08538
D Rubber mounted stud	2	07027	H Hose, Clamp, #44	4	08560	L Intake Tube	1	087036-1

The K&N® Drycharger® included with this kit must be installed on the K&N® air filter when used with this K&N® cold air intake system. The K&N® cold air intake system a performance product that can be used safely during mild weather conditions. During harsh and inclement weather conditions, you must convert your cold air intake system to a short ram configuration, or return your vehicle to the stock OEM airbox and intake tract configuration. Failure to follow these instructions can void your warranty.

NOTE: FAILURE TO FOLLOW INSTALLATION INSTRUCTIONS AND NOT USING THE PROVIDED HARDWARE MAY DAMAGE THE INTAKE TUBE, THROTTLE BODY AND ENGINE.

TO START:

1. Turn off the ignition and disconnect the negative battery cable.

NOTE: Disconnecting the negative battery cable erases pre-programmed electronic memories. Write down all memory settings before disconnecting the negative battery cable. Some radios will require an anti-theft code to be entered after the battery is reconnected. The anti-theft code is typically supplied with your owner's manual. In the event your vehicles' anti-theft code cannot be recovered, contact an authorized dealership to obtain your vehicles anti-theft code.



2. Disconnect the air temperature sensor electrical connection as shown.



3. Unclip the battery cable from the air inlet duct as shown.



4. Loosen and remove the two bolts that secure the air inlet duct as shown.



5. Remove the air inlet duct.



6. Loosen and remove the four bolts that secure the air intake resonator.



7. Loosen and remove the two bolts that secure the throttle body plenum.



8. Loosen the hose clamp that secures the plenum to the throttle body as shown.



9. Using a pair of pliers, depress and pull back the hose clamp on the crank case vent at the cam cover.

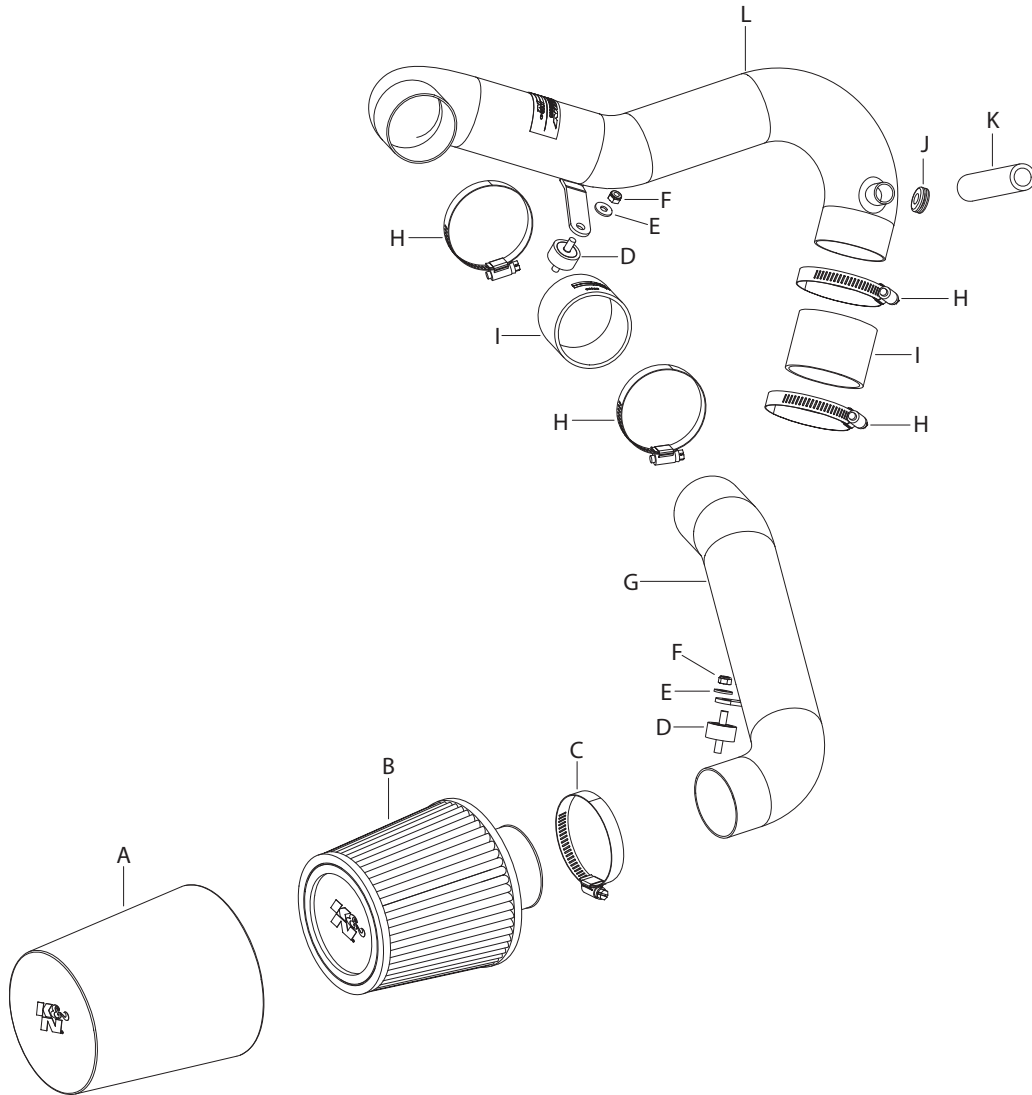



10. Pull firmly upwards to remove the throttle body plenum as shown.



11. Using a flat blade screwdriver, unclip the wire harness from the resonator as shown.



12. Unclip the throttle cable and cruise control cable (if equipped), then, remove the resonator by pulling upwards as shown.
NOTE: K&N Engineering, Inc., recommends that customers do not discard factory air intake.



13. Secure the throttle cable and cruise control cable (if equipped) to the stock clips as shown.



14. Install the silicone hose and hose clamps onto the throttle body. Do not tighten at this time.



15. Install the rubber mounted stud onto the stock resonator mounting location as shown.



16. Remove the air temperature sensor from the throttle body plenum as shown.
NOTE: Take care removing the temp sensor as it is very fragile.



17. Install the provided rubber grommet into the hole on the K&N® intake tube, then install the air temperature sensor into the grommet as shown.
NOTE: Before installing the grommet and air temperature sensor, inspect the inside of the tube for any debris, then clean the inside out with water and a towel. Inspect the tube one more time before proceeding to the next step.
NOTE: Take care when handling the temp sensor as it is very fragile.



18. Install the K&N® intake tube onto the throttle body, then, line up the bracket with the rubber mounted stud as shown. Tighten hose clamps at this time.



19. Secure the bracket to the rubber mounted stud using the provided hardware, but do not tighten completely at this time.



20. Install the remaining rubber mounted stud to the lower resonator mounting point as shown.



21. Install the silicone hose and hose clamps onto the K&N® cold air tube as shown.



22. Install the tube as shown turning the tube in a clockwise rotation while inserting the tube in between the battery tray and the starter solenoid.



23. Slide the K&N® cold air tube onto the throttle body tube and line up the bracket with the rubber mounted stud as shown and secure with the provided hardware. Do not tighten completely.



24. Install the K&N® Drycharger® onto the K&N® air filter as shown.

NOTE: Please be aware the Drycharger® is water repellent, not water proof. Depending on conditions and usage the water repellent treatment is good for 1 to 2 years. See the parts list to reorder a new Drycharger® if necessary.



25. Raise the vehicle up and support it with jack stands, then, install the K&N® air filter from underneath the vehicle as shown.



26. Install the provided silicone hose onto the crank case vent on the cam cover, then connect the other end to the vent on the K&N® intake tube as shown.



27. Reconnect the air temperature sensor electrical connection as shown.



28. This K&N® high flow intake system has been designed to be used in two different configurations. In the case of inclement weather, the cold air tube can be removed and the air filter can be clamped onto the intake tube located in the engine compartment to avoid the possibility of ingesting water into the engine.

NOTE: If you have any concerns, return the vehicle to stock using the factory equipment.

29. Reconnect the vehicle's negative battery cable. Double check to make sure everything is tight and properly positioned before starting the vehicle.

30. The C.A.R.B. exemption sticker, (attached), must be visible under the hood, so the emissions inspector can see it when the vehicle is required to be tested for emissions. California requires testing every two years, other states may vary.

31. It will be necessary for all K&N® high flow intake systems to be checked periodically for realignment, clearance and tightening of all connections. Failure to follow the above instructions or proper maintenance may void warranty.

ROAD TESTING:

1. Start the engine with the transmission in neutral or park, and the parking brake engaged. Listen for air leaks or odd noises. For air leaks secure hoses and connections. For odd noises, find cause and repair before proceeding. This kit will function identically to the factory system except for being louder and much more responsive.

2. Test drive the vehicle. Listen for odd noises or rattles and fix as necessary.

3. If road test is fine, you can now enjoy the added power and performance from your kit.

4. K&N Engineering, Inc., suggests checking the air filter element periodically for excessive dirt build-up. When the element becomes covered in dirt (or once a year), service it according to the instructions on the Recharger® service kit, part number 99-5050 or 99-5000

STREET LEGAL IN MOST STATES

**NOT LEGAL FOR USE IN CA & OTHER STATES
ADOPTING CA EMISSIONS STANDARDS**

See our catalog or knfilters.com for CARB status on each part for a specific vehicle

* FREE K&N® decal To register your warranty, please see us online at knfilters.com/register. FREE K&N® decal *

• 1455 CITRUS ST., P.O. BOX 1329, RIVERSIDE, CA., U.S.A. 92502 • TECH SERVICE 800-858-3333 • FAX 951-826-4001
• e-mail: tech@knfilters.com • WWW: <http://www.knfilters.com>

174004L
10/24/11