



AIRCHARGER®

INSTALLATION INSTRUCTIONS

63-9022

TOYOTA

2003-04 4RUNNER

V8-4.7L

NOTE: This kit was not designed to fit vehicles with a body lift.

TOOLS NEEDED:

- Phillips Screwdriver
- Flat Blade Screwdriver
- 4mm allen
- 2.5mm allen
- Ratchet
- Extension
- 10mm Wrench
- Plier
- 10mm Socket
- 12mm Socket
- 13mm Socket

NOTE: FAILURE TO FOLLOW INSTALLATION INSTRUCTIONS AND NOT USING THE PROVIDED HARDWARE MAY DAMAGE THE INTAKE TUBE, THROTTLE BODY AND ENGINE.

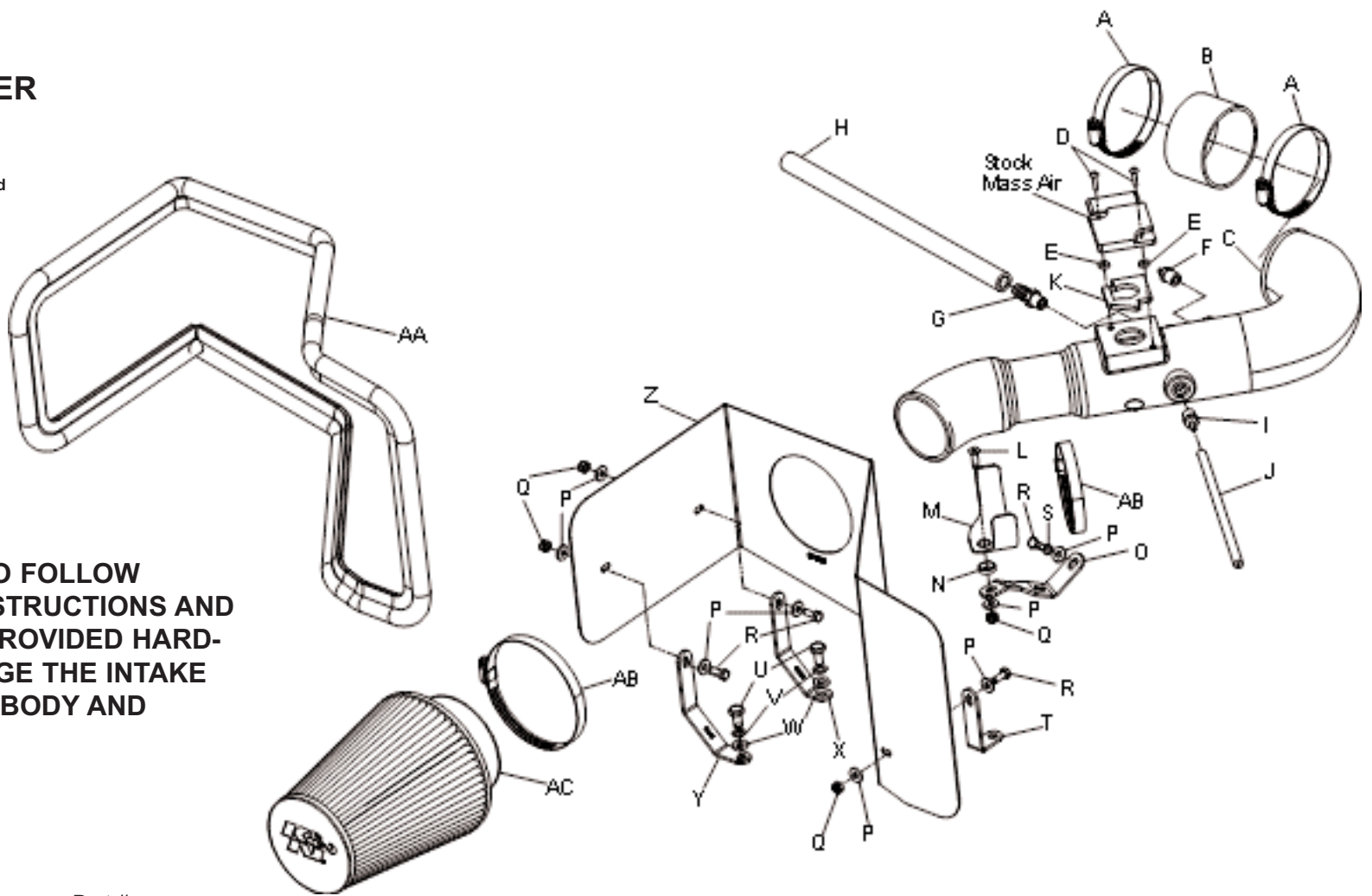

PARTS LIST:

Desc.	QTY.	Part #	Desc.	QTY.	Part #	Desc.	QTY.	Part #
A hose clamp #48	2	08601	I vent 3/16barbed 1/4"npt	1	080021	Q nut; 6mm nylock	4	07553
B silicone hose	1	08690	J silicone hose 4mm id x 9"l	1	08139	R bolt; 1.x16mm hex hd.	4	07703
C intake tube (DA)	1	087095	K mass air gasket	1	09026	S washer; 1/4" lock, zn	1	08198
D screw buttonhead	2	07793	L bolt; 1.00 x 20mm f/h/a	1	08376	T bracket "L" short	1	070632
E spacer .437"odx.2"idx.	2	06503	M saddle bracket	1	078855	U bolt; 1.25x16mm, hexhd	2	07844
F vent 1/8hose, 1/4npt.	1	08052	N washer; nylon black	1	08180	V washer; 8mm spring	2	08239
G vent 1/2"hose 1/4"npt	1	080022	O bracket	1	07173	W washer; 5/16"idx5/8"od	2	08276
H silicone hose 1/2"idx14"l	1	08402	P washer; 1/4"id x 5/8"od	8	08275	X bracket med "L"	1	07172
						Y bracket med "L"	1	07171
						Z heat shield	1	074005
						AA edge trim 75"	1	102460
						AB hose clamp #52	2	08610
						AC air filter	1	RC-5100

TO START:

1. Turn the ignition OFF and disconnect the vehicle's negative battery cable.



2. Loosen the two nuts that secure the throttle body cover then remove the throttle body cover.



3. Disconnect the mass air sensor electrical connection, then release wire loom from air box.

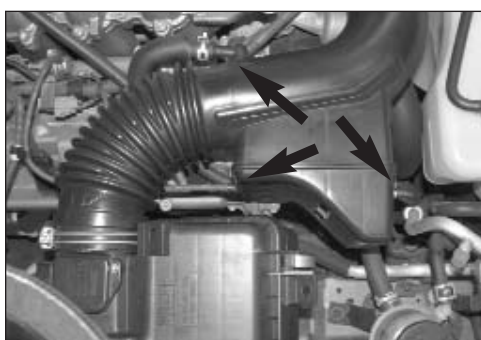

4. Remove the three vent lines from the air intake resonator as shown.



5. Loosen the hose clamp at the throttle body and air box, then remove intake tube from vehicle.



6. Remove the air box lid and filter to gain access to the three bolts that retain the air box to vehicle.



7. Remove the three bolts that retain the air box to vehicle, then remove the air box.



8. Remove the 12mm bolt that retains the power steering reserve to vehicle then mount the provided bracket (070632) onto the vehicle with the bolt that was removed.



9. Mount the two provided brackets onto the vehicle with the provided hardware. **NOTE: Bracket (07172) mounts closest to engine.**



10. Install the edge trim onto the heat shield as shown. Trim if needed.



11. Install the heat shield onto the vehicle then secure to brackets with the provided hardware.



12. Assemble the saddle bracket assembly with the provided hardware as shown.



13. Install the saddle bracket assembly onto the threaded boss on the cam cover with the provided hardware as shown.



14. Install the provided silicone hose (08690) onto the throttle body with the provided hose clamp.



15. Remove the two screws that secure the mass air sensor to the air box lid, then remove the mass air sensor as shown.



16. Apply the gasket to the mass air sensor, sticky side down as shown.



17. Secure the mass air sensor to the K&N intake tube using the provided screws and spacers as shown.



18. Assemble the vent fittings onto the K&N intake tube as shown.



19. Install the K&N intake tube onto the throttle body and align with the saddle bracket.



20. Secure the K&N intake tube to the saddle bracket with the provided hose clamps also tighten the hose clamp at the throttle body.



21. Install the provided silicone hose onto the K&N intake tube and re-connect the one existing vent line as shown.



22. Install the K&N air filter onto the intake tube as shown.



23. Disconnect the ground strap that's attached to the mass air sensor wiring harness at the inner fender as shown.



24. Using the bolt that was removed in the previous step, connect the ground strap to wheel well as shown.



25. Reconnect the mass air sensor electrical connections.



26. Re-install the throttle body cover as shown.



27. Reconnect the vehicle's negative battery cable. Double check to make sure everything is tight and properly positioned before starting the vehicle.

28. The C.A.R.B. exemption sticker, (attached), must be visible under the hood so that an emissions inspector can see it when the vehicle is required to be tested for emissions. California requires testing every two years, other states may vary.

29. It will be necessary for all FIPK's to be checked periodically for realignment, clearance and tightening of all connections. Failure to follow the above instructions or proper maintenance may void warranty.

ROAD TESTING:

1. Start the engine with the transmission in neutral or park, and the parking brake engaged. Listen for air leaks or odd noises. For air leaks secure hoses and connections. For odd noises, find cause and repair before proceeding. This kit will function identically to the factory system except for being louder and much more responsive.

2. Test drive the vehicle. Listen for odd noises or rattles and fix as necessary.

3. If road test is fine, you can now enjoy the added power and performance from your kit.

4. K&N suggests checking the air filter element periodically for excessive dirt build-up. When the element becomes covered in dirt (or once a year), service it according to the instructions on the Recharger service kit, part number 99-5050 or 99-5000.

FREE K&N DECAL To register your warranty, please see us online at knfilters.com/register. FREE K&N DECAL