



# AIRCHARGER™

## HIGH-FLOW INTAKE KITS



### INSTALLATION INSTRUCTIONS

**63-3073**  
**CHEVROLET**  
**2008-12 Corvette**  
**V8-6.2L**

**NOTE: 63-3073 excludes Chevrolet Corvette ZR1 models**

**TOOLS NEEDED:**

- 2.5mm allen wrench
- 4mm allen wrench
- flat blade screwdriver
- T20 TORX

**PARTS LIST:**

Description	Qty.	Part #
A Hose Clamp #64 Stainless	2	08645
B Hose; 4" ID X 2" L Reinforced	1	08761
C Bolt; M4 X .7 X 8MM, Buttonhead, SS	2	07741
D Bolt; M6 X 1.00 X 16MM, Buttonhead, SS	2	07730
E Washer; 6MM Flat, SS	2	08269
F Adaptor; #420, Nylon 6/6 GF, Black	1	21515
G Gasket; 3/16 Poron	1	09069
H Intake Tube (HO)	1	087228
I Grommet; 15/16"OD, 3/8"ID, 17/32"Thk	1	08100
J Hose Clamp #116	2	08647
K Hose; 2-3/4" X 8-3/4" ID X 1-3/4" L Oval	1	08619
L Air Filter	1	RP-5161

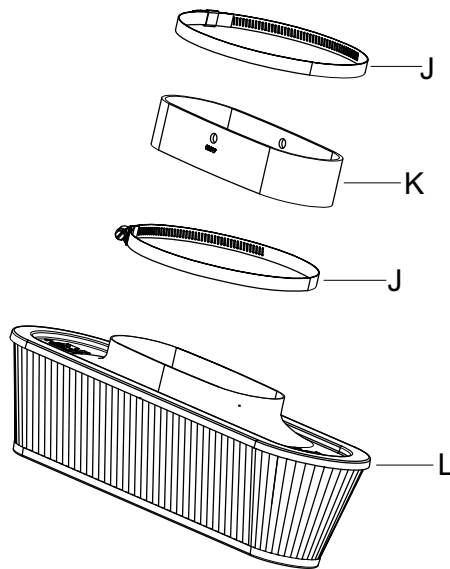
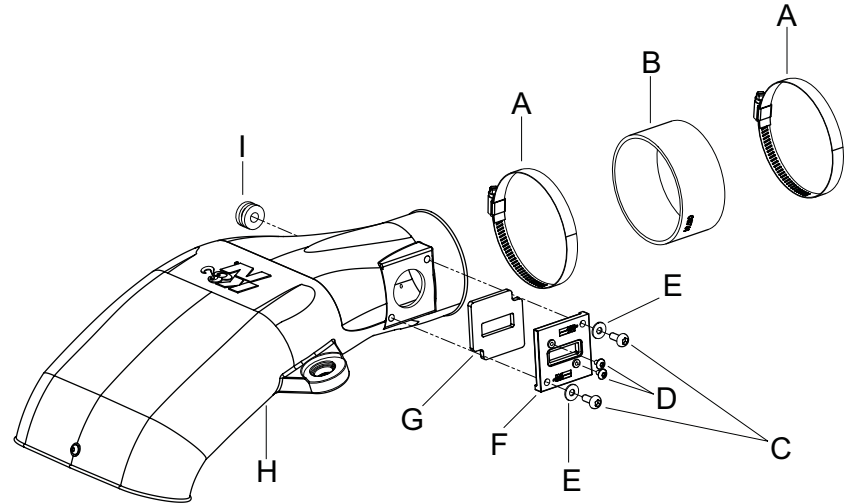

**NOTE: FAILURE TO FOLLOW INSTALLATION INSTRUCTIONS AND NOT USING THE PROVIDED HARDWARE MAY DAMAGE THE INTAKE TUBE, THROTTLE BODY AND ENGINE.**

**TO START:**

1. Turn off the ignition and disconnect the negative battery cable.  
**NOTE: Disconnecting the negative battery cable erases pre-programmed electronic memories. Write down all memory settings before disconnecting the negative battery cable. Some radios will require an anti-theft coded to be entered after the battery is reconnected. The anti-theft code is typically supplied with your owner's manual. In the event your vehicles' anti-theft code cannot be recovered, contact an authorized dealership to obtain your vehicles anti-theft code.**



2. Unlock and disconnect the crankcase vent tube from the intake tube as shown.



3. Disconnect the mass air sensor electrical connection as shown.



4. Loosen the hose clamp which secures the stock intake tube to the throttle body.



5. Lift up and remove the complete stock intake system from the vehicle as shown.  
**NOTE: K&N Engineering, Inc., recommends that customers do not discard factory air intake.**

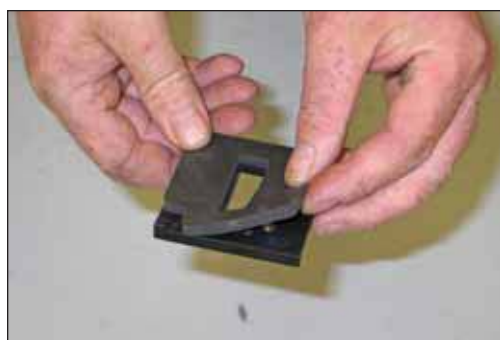

6. Install the provided gasket onto the mass air sensor adapter as shown.



7. Remove the two screws which secure the mass air sensor to the stock intake tube and then remove the mass air sensor from the intake tube as shown.

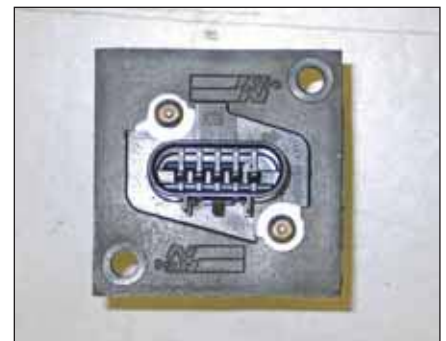

8. Install the mass air sensor into the K&N® mass air sensor adapter and secure with the provided screws.



9. Install the mass air sensor assembly into the K&N® intake tube as shown and secure with the provided hardware.  
**NOTE: Be sure to install the mass air sensor with the opening towards the filter end of the tube.**



10. Remove the crankcase vent fitting from the stock intake tube.



11. Install the provided grommet into K&N® intake tube as shown.



12. Install the factory crankcase vent fitting into the grommet as shown.



13. Remove the two intake tube mounting grommets from the stock intake tube.

**NOTE: The grommets may stick the mounting studs when removing the system from the vehicle.**



14. Install the two mounting grommets into the K&N® intake tube.



15. Install the provided silicone hose (08619) onto the K&N® intake tube and secure with the provided hose clamp.



16. Install the K&N® air filter onto the K&N® intake tube as shown and secure with the provided hose clamp.

**NOTE: Drycharger® air filter wrap; part number RP-5135DK is available to purchase separately. To learn more about Drycharger® filter wraps or look up color availability please visit <http://www.knfilters.com>.**



17. Install the provided silicone hose (08761) onto the throttle body and secure with the provided hose clamp.



18. Install the K&N® intake assembly on top off the radiator assembly and then connect the mass air sensor electrical connection as shown.



19. Install the K&N® intake assembly into the silicone hose on throttle body and onto the mounting studs. Secure with the provided hose clamp. Reconnect the crank case vent line.



20. Reconnect the vehicle's negative battery cable. Double check to make sure everything is tight and properly positioned before starting the vehicle.

21. It will be necessary for all K&N® high flow intake systems to be checked periodically for realignment, clearance and tightening of all connections. Failure to follow the above instructions or proper maintenance may void warranty.

#### ROAD TESTING:

1. Start the engine with the transmission in neutral or park, and the parking brake engaged. Listen for air leaks or odd noises. For air leaks secure hoses and connections. For odd noises, find cause and repair before proceeding. This kit will function identically to the factory system except for being louder and much more responsive.

2. Test drive the vehicle. Listen for odd noises or rattles and fix as necessary.

3. If road test is fine, you can now enjoy the added power and performance from your kit.

4. K&N Engineering, Inc., requires cleaning the intake system's air filter element every 100,000 miles. When used in dusty or off-road environments, our filters will require cleaning more often. We recommend that you visually inspect your filter once every 25,000 miles to determine if the screen is still visible. When the screen is no longer visible some place on the filter element, it is time to clean it. To clean and re-oil, purchase our filter Recharger® service kit, part number 99-5050 or 99-5000 and follow the easy instructions.

**STREET LEGAL IN MOST STATES**

**NOT LEGAL FOR USE IN CA & OTHER STATES  
ADOPTING CA EMISSIONS STANDARDS**

**See our catalog or [knfilters.com](http://knfilters.com) for CARB status on each part for a specific vehicle**

\* FREE K&N® decal To register your warranty, please see us online at [knfilters.com/register](http://knfilters.com/register). FREE K&N® decal \*

• 1455 CITRUS ST., P.O. BOX 1329, RIVERSIDE, CA., U.S.A. 92502 • TECH SERVICE 800-858-3333 • FAX 951-826-4001  
• e-mail: [tech@knfilters.com](mailto:tech@knfilters.com) • WWW: <http://www.knfilters.com>