



AIRCHARGER™ HIGH-FLOW INTAKE KITS

INSTALLATION INSTRUCTIONS

63-3069

**CHEVROLET
2008-09 HHR SS
L4 - 2.0L Turbo**

TOOLS NEEDED:

flat blade screwdriver
ratchet
extension
T25 TORX

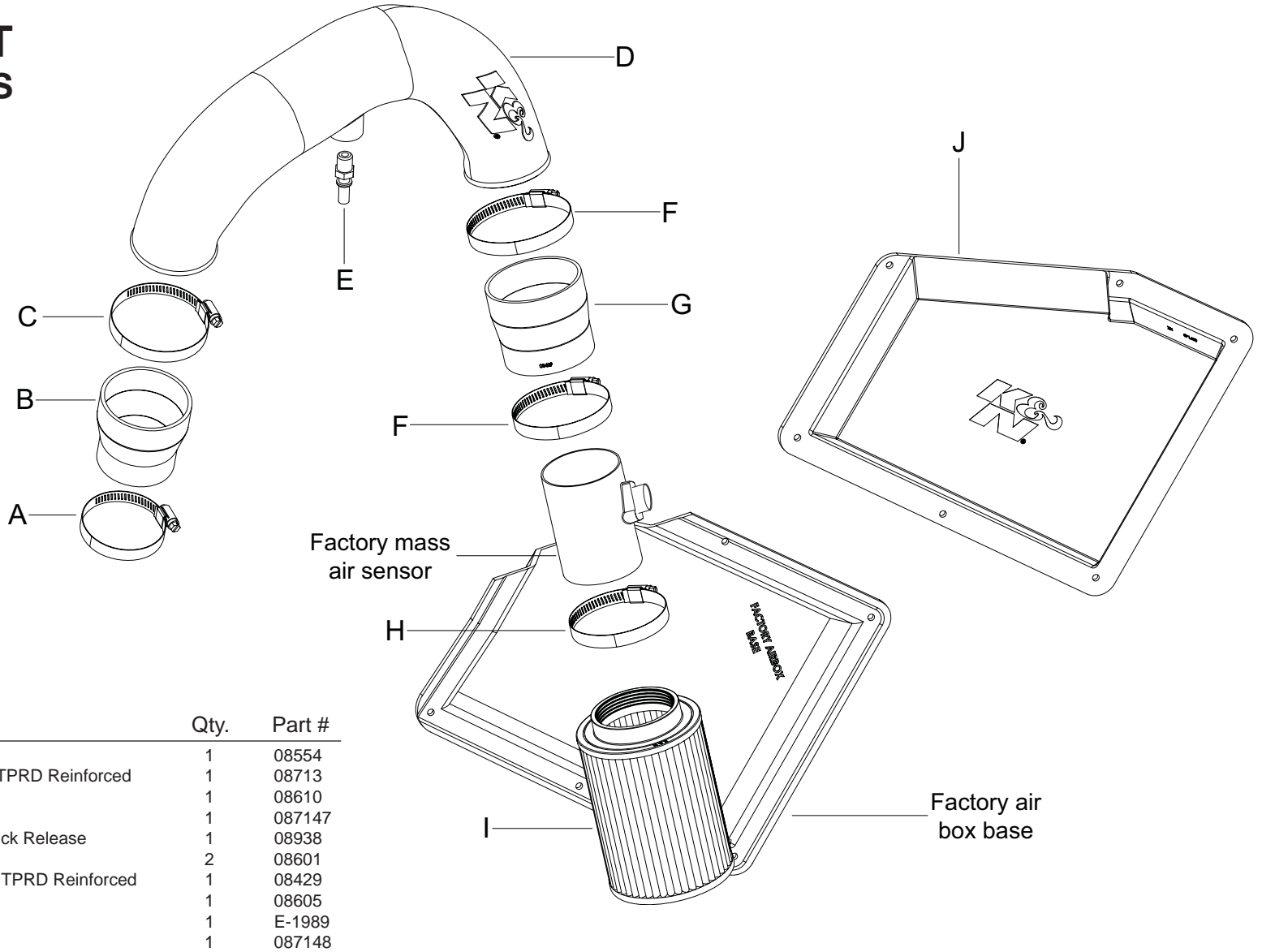

PARTS LIST:

Description	Qty.	Part #
A Hose Clamp #40	1	08554
B Hose; 3" To 2-1/2" ID X 3" L TPRD Reinforced	1	08713
C Hose Clamp #52	1	08610
D Intake tube (HJ)	1	087147
E Vent; STRT, 1/4" NPT To Quick Release	1	08938
F Hose Clamp #48	2	08601
G Hose; 3-1/4" TO 3" ID X 3" L TPRD Reinforced	1	08429
H Hose Clamp #48 Midi	1	08605
I Air Filter	1	E-1989
J Air Box Lid (HK)	1	087148

NOTE: FAILURE TO FOLLOW INSTALLATION INSTRUCTIONS AND NOT USING THE PROVIDED HARDWARE MAY DAMAGE THE INTAKE TUBE, THROTTLE BODY AND ENGINE.

TO START:

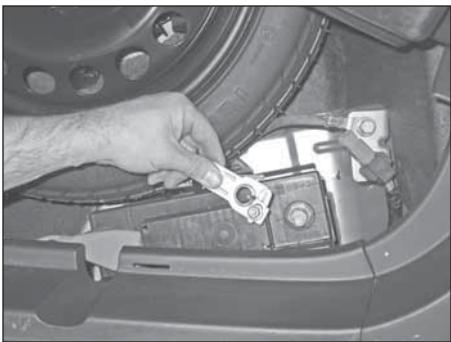

1. Turn off the ignition and then disconnect the negative battery cable. The battery is located in the trunk next to the spare tire.

NOTE: Disconnecting the negative battery cable erases pre-programmed electronic memories. Write down all memory settings before disconnecting the negative battery cable. Some radios will require an anti-theft code to be entered after the battery is reconnected. The anti-theft code is typically supplied with your owner's manual. In the event your vehicles' anti-theft code cannot be recovered, contact an authorized dealership to obtain your vehicles anti-theft code.

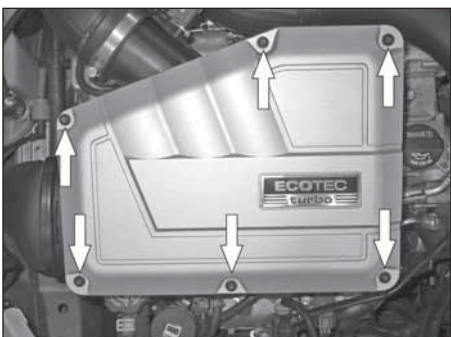

2. Remove the six TORX screws which secure the air box lid and then remove the air box lid from the vehicle.



3. Remove the stock air filter from the air box as shown.

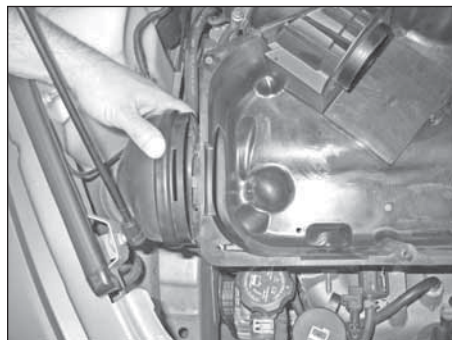

4. Disconnect the fresh air inlet duct from the air box as shown.



5. Loosen the hose clamp and then disconnect the stock intake tube from the air box.

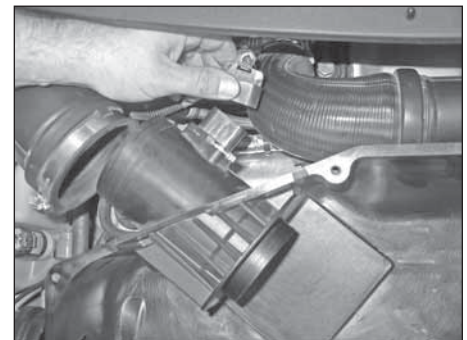

6. Disconnect the mass air sensor electrical connection.



7. Remove the two clips securing the front of the air box to the engine and then remove the complete air box assembly from the vehicle.



8. Release the crank case vent tube from the fitting on the stock intake tube.

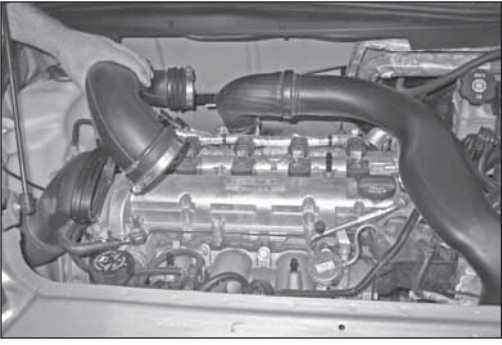

9. Loosen the hose clamp which secures the stock intake tube to the turbo inlet and then remove the intake tube from the vehicle.

NOTE: K&N Engineering, Inc., recommends that customers do not discard factory air intake.

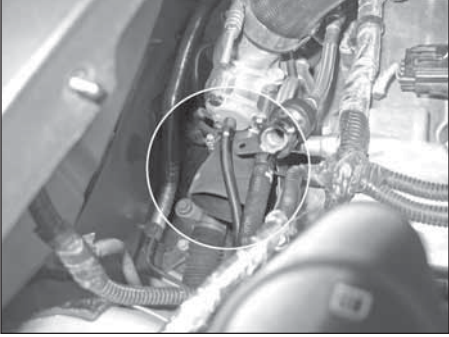

10. Install the provided silicone hose (08713) onto the turbo inlet and secure with the provided hose clamp.

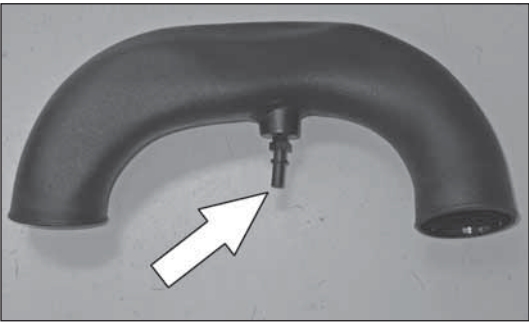

11. Install the provided crank case quick connect fitting into the K&N® intake tube as shown.

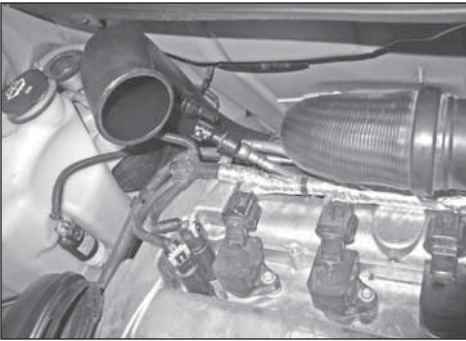

12. Install the K&N® intake tube into the silicone hose at the turbo inlet and secure with the provided hose clamp.



13. Connect the crank case vent hose to the quick connect fitting.

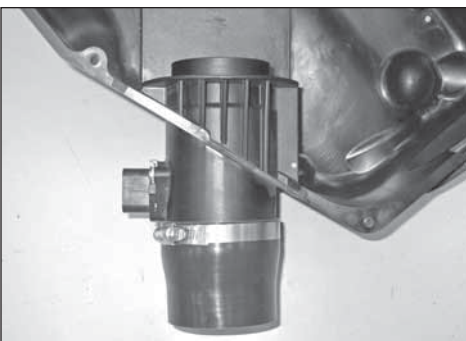

14. Install the provided silicone hose (08429) onto the factory air box and secure with the provided hose clamp.

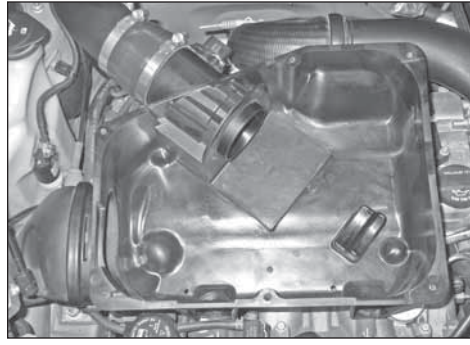

15. Install the air box onto the engine, connect the intake tube and secure with the provided hose clamp. Reinstall the retaining clips to secure the front of the air box. Reconnect the fresh air inlet tube to the air box.

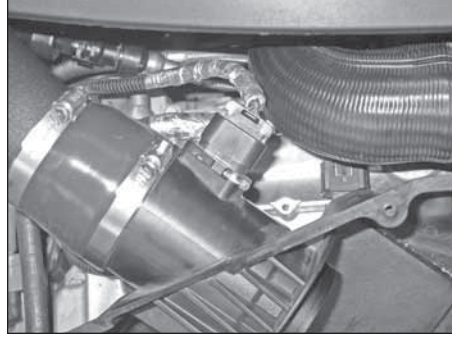

16. Reconnect the mass air sensor electrical connection.

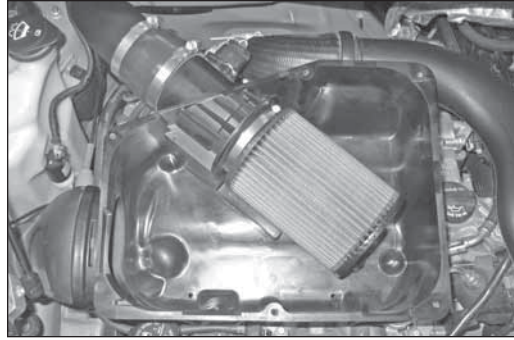

17. Install the K&N® air filter and secure with the provided hose clamp.

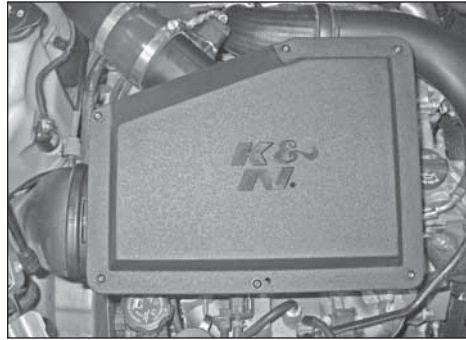

18. Install the K&N® air box lid and secure with the six factory screws.

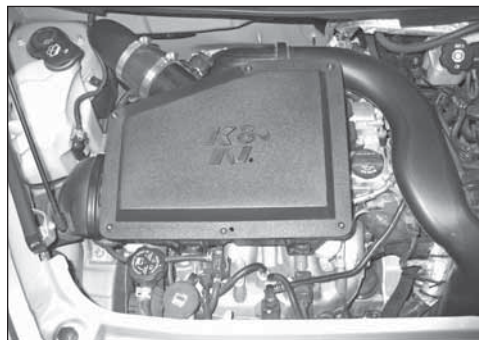

19. Reconnect the vehicle's negative battery cable. Double check to make sure everything is tight and properly positioned before starting the vehicle.

20. It will be necessary for all K&N® high flow intake systems to be checked periodically for realignment, clearance and tightening of all connections. Failure to follow the above instructions or proper maintenance may void warranty.

ROAD TESTING:

1. Start the engine with the transmission in neutral or park, and the parking brake engaged. Listen for air leaks or odd noises. For air leaks secure hoses and connections. For odd noises, find cause and repair before proceeding. This kit will function identically to the factory system except for being louder and much more responsive.

2. Test drive the vehicle. Listen for odd noises or rattles and fix as necessary.

3. If road test is fine, you can now enjoy the added power and performance from your kit.

4. K&N Engineering, Inc., suggests checking the air filter element periodically for excessive dirt build-up. When the element becomes covered in dirt (or once a year), service it according to the instructions on the Recharger® service kit, part number 99-5050 or 99-5000.

* FREE K&N® decal To register your warranty, please see us online at knfilters.com/register. FREE K&N® decal *