



AIRCHARGER[®]

HIGH-FLOW INTAKE KITS

INSTALLATION INSTRUCTIONS

63-3066

CHEVROLET / GMC

2007-09 Silverado 2500 HD / 3500 HD

2007-09 Sierra 2500 HD / 3500 HD

V8-6.6L Turbo Diesel

NOTE: This kit was not designed to fit vehicles with a body lift.

TOOLS NEEDED:

- Flat Blade Screwdriver
- Ratchet
- Extension
- 10mm Socket
- T20 Torx
- 3.0mm Allen Wrench
- 4.0mm allen Wrench
- 10mm Wrench
- 8mm Wrench.

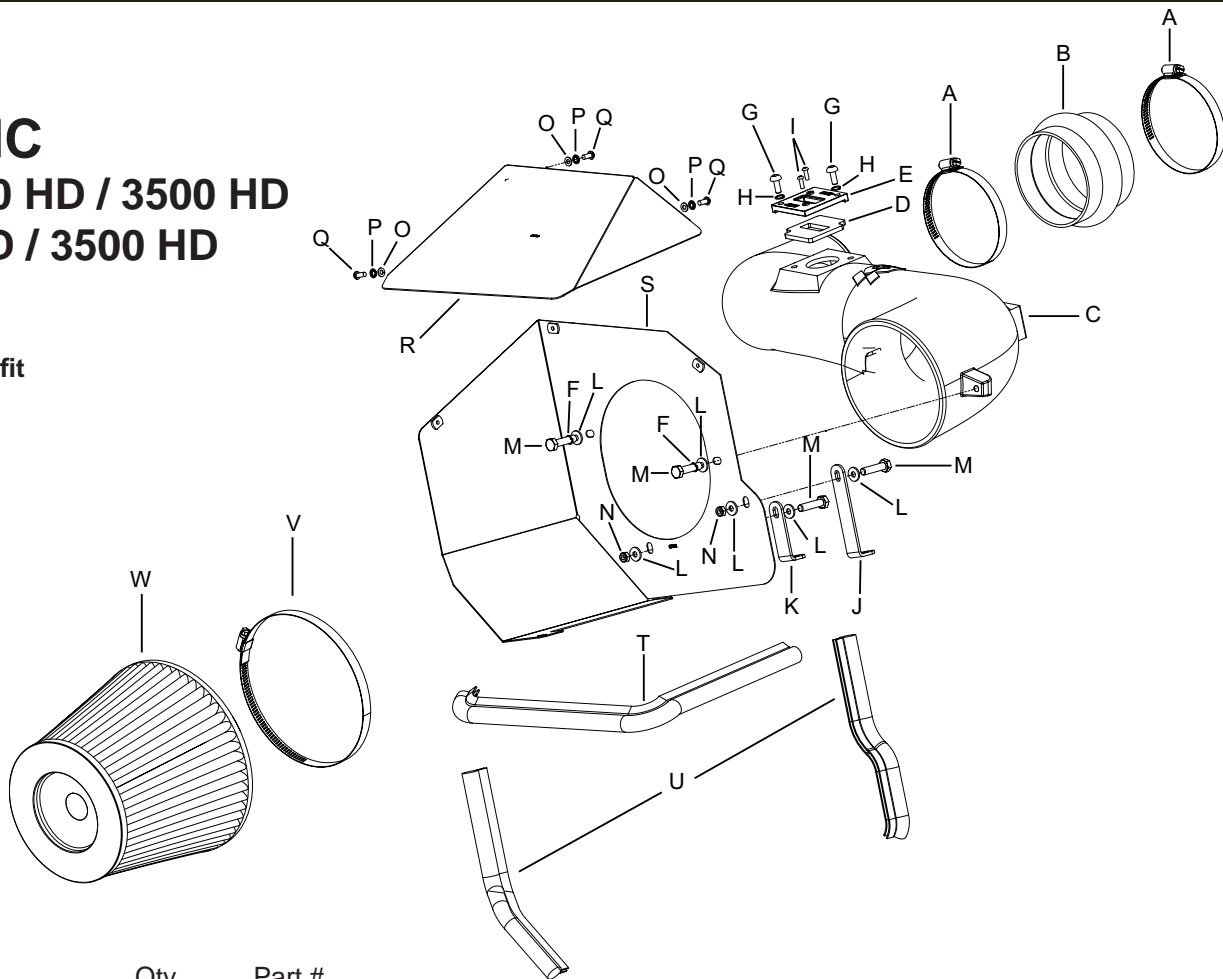

PARTS LIST:

Description	Qty.	Part #	Description	Qty.	Part #
A Hose Clamp #64	2	08648	M Bolt; M6-1.00 X 16MM Hex Head.	4	07703
B Hose; 5.0" 4.19"X3"L, Humped Silicone	1	08617	N Nut; 6MM Nylock, Hexhead, SS	2	07512
C Intake Tube	1	087224	O Washer; 5MM Flat, SS	3	08212
D Gasket; 3/16 Poron	1	09069	P Washer; 5MM Internal Star Cut Lock	3	07724
E Adaptor; Nylon 6/6 GF, Black	1	21515	Q Bolt; 5MM-.80 X 16MM Hex Head	3	22204
F Washer; 1/4" Lock, ZN	2	08198	R Heat Shield	1	07673
G Bolt; M6 X 1.00 X 16MM , Buttonhead, SS	2	07730	S Heat Shield	1	07672
H Washer; 6MM Flat, SS	2	08269	T Edge Trim (20")	1	102494
I Bolt; M4 X .7 X 8MM, Buttonhead, SS	2	07741	U Edge Trim (11")	2	102468
J Bracket; L-Bend	1	07805	V Hose Clamp #104	1	08697
K Bracket; L-Bend	1	070952	W Air Filter	1	RC-5177
L Washer; 1/4"ID X 5/8"OD - SAE	6	08275			

NOTE: FAILURE TO FOLLOW INSTALLATION INSTRUCTIONS AND NOT USING THE PROVIDED HARDWARE MAY DAMAGE THE INTAKE TUBE, THROTTLE BODY AND ENGINE.

TO START:

1. Turn off the ignition and disconnect the negative battery cable.

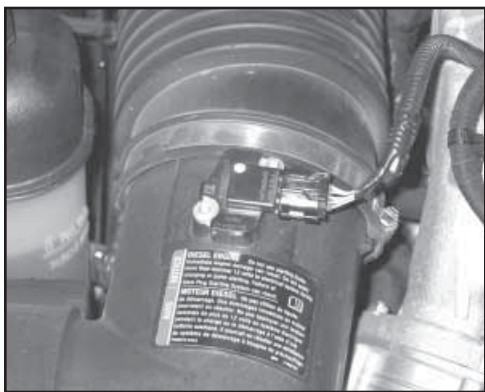

2. Depress the locking tab and then disconnect the Mass air sensor electrical connection.

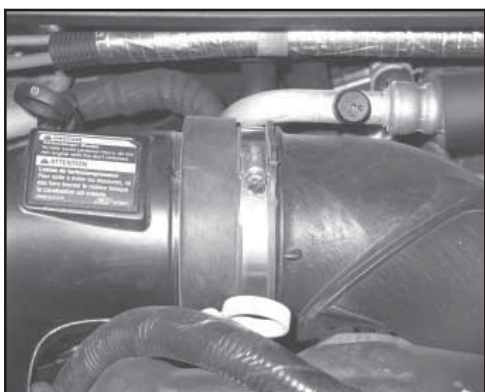

3. Loosen the hose clamp which secures the stock intake tube to the turbo inlet tube.

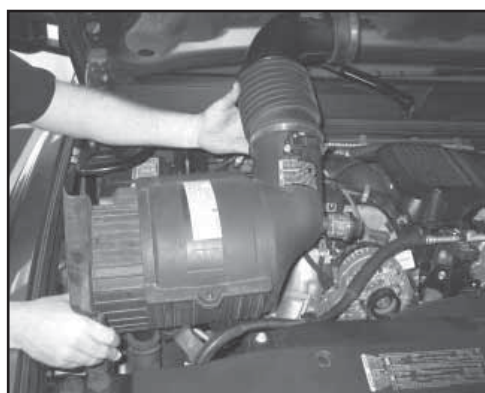

4. Disconnect the stock intake tube from the turbo inlet tube and then lift the complete stock intake assembly from the vehicle as shown.

NOTE: K&N recommends that customers do not discard factory air intake.

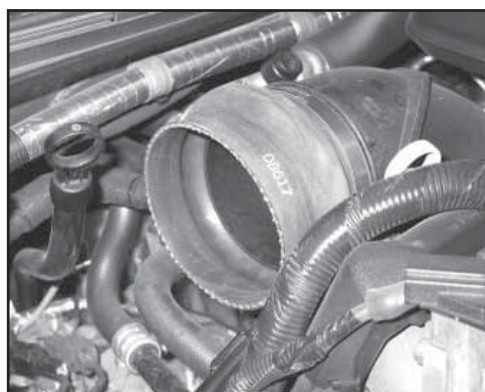

5. Install the provided silicone hose (08617) onto the turbo inlet tube and secure with the provided hose clamp.

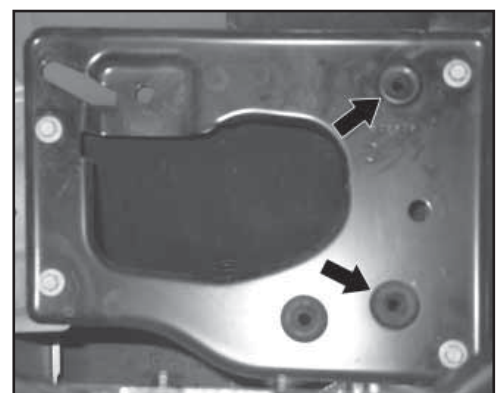

6. Remove the two air box mounting grommets shown from the air box mounting plate.

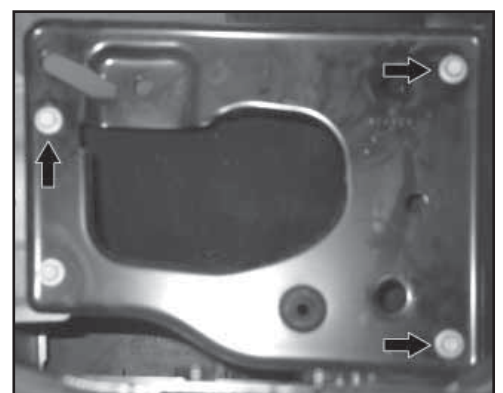

7. Remove the three air box mounting plate bolts shown.

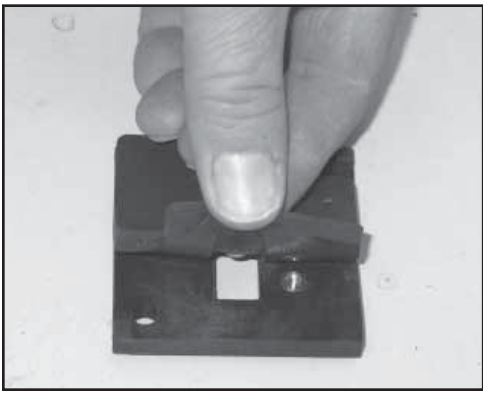

8. Install the provided gasket onto the mass air sensor adapter as shown.

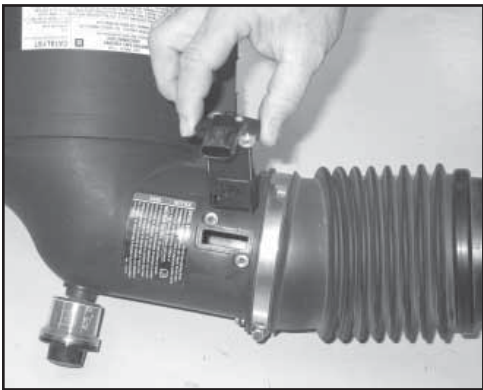

9. Remove the two screws that secure the mass air sensor onto the stock intake tube and then remove the mass air sensor as shown.

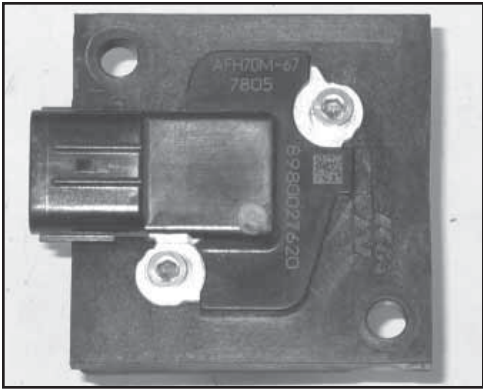

10. Install the mass air sensor into the adapter and secure with the provided hardware.

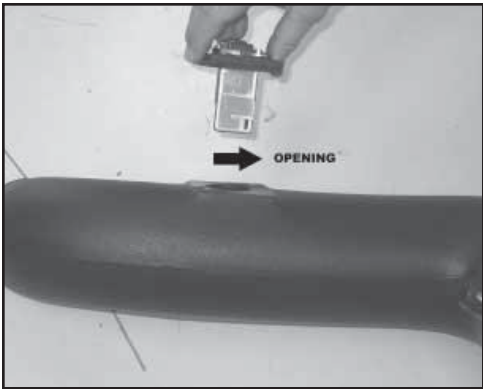

11. Install the mass air sensor assembly into the K&N Intake Tube.
NOTE: Be sure the opening of the mass air sensor is pointed towards the filter end of the tube.

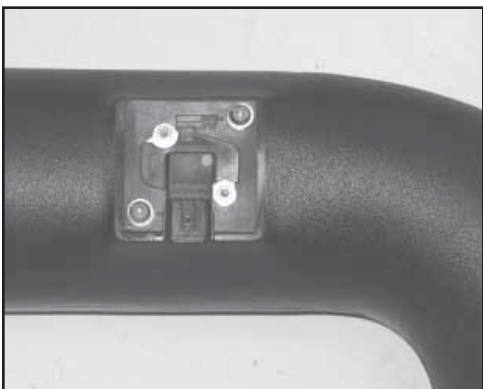

12. Secure the mass air sensor assembly to the K&N Intake Tube with the provided hardware.

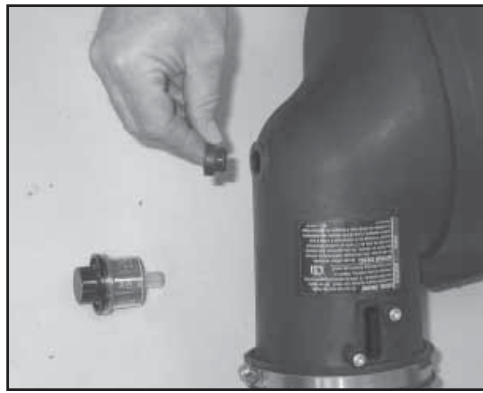

13. Remove the filter minder and grommet from the stock intake tube as shown.



14. Install the filter minder and grommet into the K&N Intake Tube as shown.

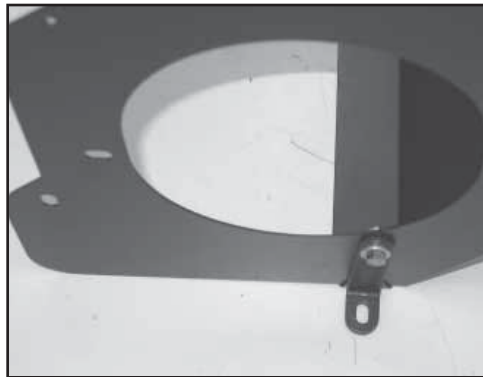

15. Install the "L" bracket (07805) onto the heat shield as shown with the provided hardware.

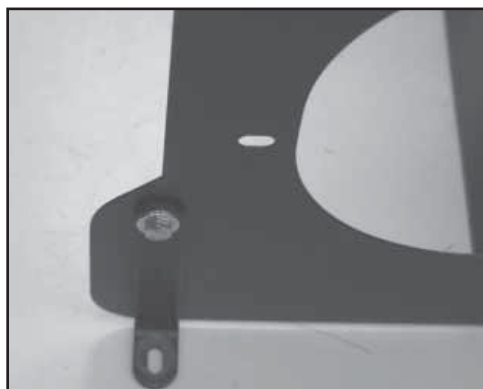

16. Install the "L" bracket (070952) onto the heat shield as shown using the provided hardware.

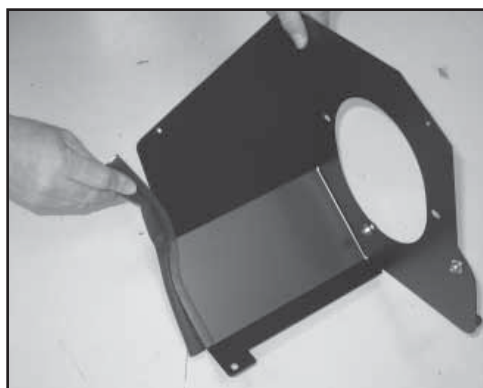

17. Install one of the 11" edge trims onto the heat shield as shown.
NOTE: Some trimming of the edge trim may be necessary.

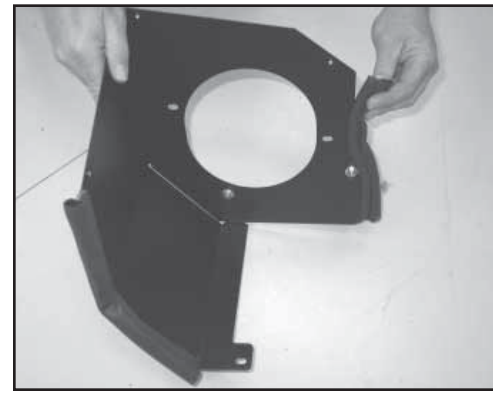

18. Install the remaining 11" edge trim onto the heat shield as shown.

NOTE: Some trimming of the edge trim may be necessary.

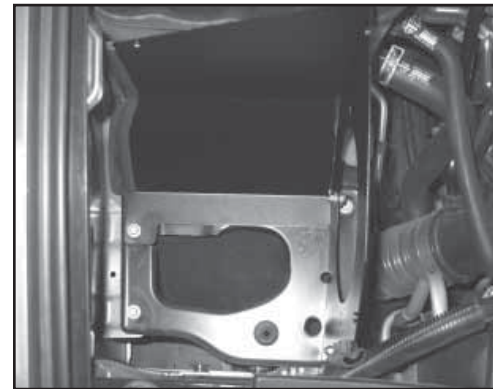

19. Install the Heat shield assembly onto the factory air box mounting plate and secure with the factory bolts removed in step #7.

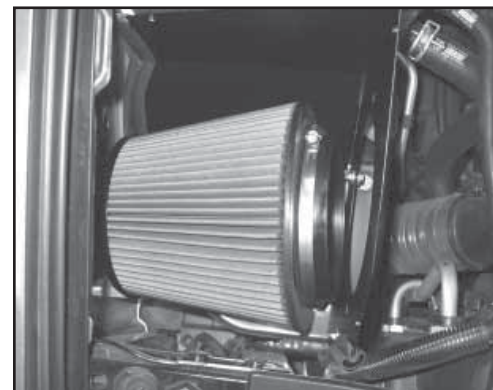

20. Set the K&N Air Filter into the heat shield as shown.

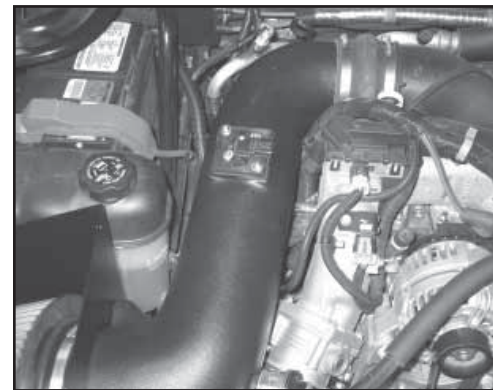

21. Install the K&N Intake Tube into the silicone hose at the turbo inlet and into the heat shield, then secure the K&N Intake Tube with the provided hose clamp and hardware as shown.



22. Install the K&N Air Filter onto the intake tube and secure with the provided hose clamp.

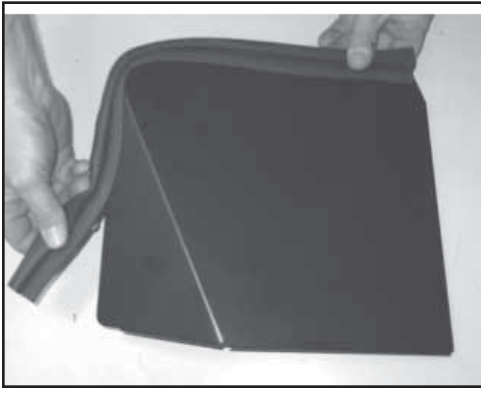

23. Install the 20" piece of edge trim onto the filter cover as shown.

NOTE: Some trimming of the edge trim may be necessary.

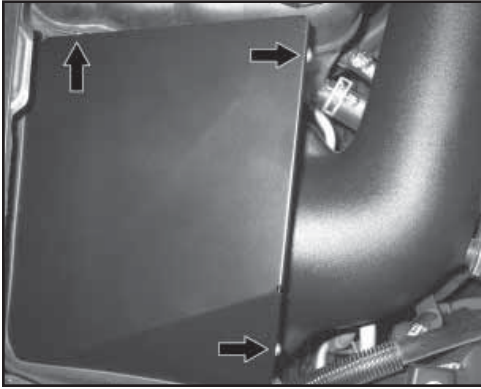

24. Install the filter cover onto the heat shield and secure with the provided hardware.

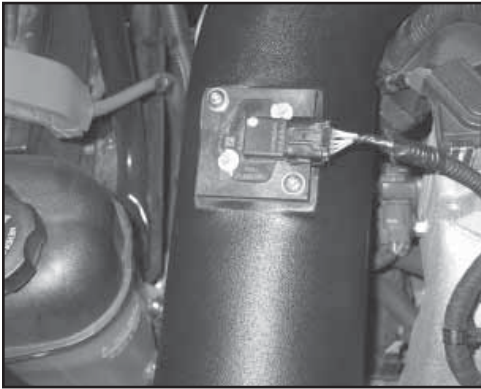

25. Reconnect the mass air sensor electrical connection.



26. Reconnect the negative battery cable. Double check to make sure everything is tight and properly positioned before starting the vehicle.

27. It will be necessary for all K&N Performance Intake Kits to be checked periodically for realignment, clearance, and tightening of all connections. Failure to follow the above instructions may void warranty.

Road Testing

1. Start the engine with the transmission in neutral or park, and the parking brake engaged. Listen for air leaks or odd noises. For air leaks secure hoses and connections. For odd noises, find cause and repair before proceeding. This kit will function identically to the factory system except for being louder and much more responsive.

2. Test drive the vehicle. Listen for odd noises or rattles and fix as necessary.

3. If road test is fine, you can now enjoy the added power and performance from your kit.

4. K&N suggests checking the air filter element periodically for excessive dirt build-up. When the element becomes covered in dirt (or once a year), service it according to the instructions on the Recharger service kit, part number 99-5050 or 99-5000.