



AIRCHARGER™

HIGH-FLOW INTAKE KITS



INSTALLATION INSTRUCTIONS

63-3064-1

Chevrolet / GMC

2007-11 Colorado / Canyon

I4-2.9L

NOTE: This kit was not designed to fit vehicles with a body lift.

TOOLS NEEDED:
Ratchet Extension, 13mm Socket, 10mm Socket, Flat Blade Screwdriver, 5/8" Wrench, 10mm Wrench, T20 Torx Wrench, 4mm Allen Wrench, 3mm Allen Wrench

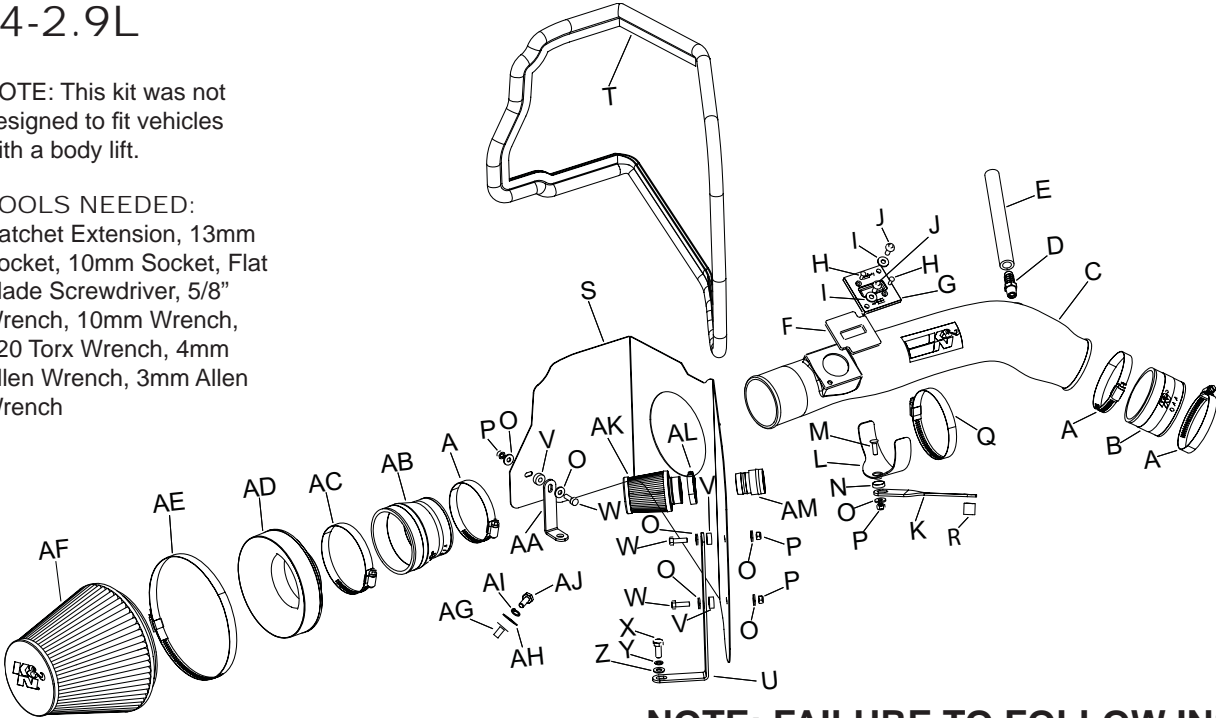

PARTS LIST:

Desc.	Qty.	Part#
A	Hose Clamp #48	08601
B	Hose; 3" ID X 2"L Black	08434
C	Intake Tube	087215
D	Vent; STRT 1/2" Hose, 1/4" NPT	080022
E	Hose; 1/2" ID X 7"L, Black Silicone	08159
F	Gasket; 3/16" Poron	09069
G	Adaptor; Nylon 6/6 GF, Black	21515
H	Screw; M4 - .7 X 12, BTNHD, SS	07726
I	Washer; 6mm Flat, SS	08269
J	Bolt; M6 X 1.00 X 16MM, BTNHD, SS	07730
K	Bracket; Mild STL FB/PC	010097
L	Bracket; Saddle, S/S	078855
M	Bolt; 6MM - 1.00 X 20MM F/H/A, SS	08376
N	Washer; Conical, Nylon, Black	08180
O	Washer; 1/4" ID X 5/8" OD - SAE	08275
P	Nut; 6MM Nylock, Hex Head, SS	07512
Q	Hose Clamp #52	08610
R	Spacer; .625" OD X .375" ID X .625" "L" ZN	07849
S	Heat Shield	07656
T	Edge Trim (66")	102472
U	Bracket; Mild STL, FB/PC	010060
V	Spacer; .625" OD X .250" ID X .250" L, Aluminum	06555
W	Bolt; M6 X 1.00" X 20MM HEX, SS	07795
X	Bolt; 8MM - 1.25 X 16MM, Hex Head	07844
Y	Washer; 5/16" ID X 5/8" OD, Flat	08276
Z	Washer; 8MM Spring (Wave)	08239
AA	Bracket; "L"	070602
AB	Hose; 3.5" ID To 3" ID Trpd. Silicone	08724
AC	Hose Clamp #56	08620
AD	Adaptor; #380	21512
AE	Hose Clamp #104	08697
AF	Air Filter	RF-1048
AG	Insert; 1/4"-20 X .500"OD X .785"L	081011
AH	Washer; 1"D X 1/4 Hole	08160
AI	Washer; 1/4" Lock, ZN	08198
AJ	Bolt; 1/4-20 X 1"L Hex	08314
AK	Air Filter	RC-2540
AL	Hose Clamp; #20 Mini	08431
AM	Adaptor; 1-1/8"OD Quick-Connect, Blk	088012

NOTE: FAILURE TO FOLLOW INSTALLATION INSTRUCTIONS AND NOT USING THE PROVIDED HARDWARE MAY DAMAGE THE INTAKE TUBE, THROTTLE BODY AND ENGINE.

TO START:

1. Turn off the ignition and disconnect the vehicle's negative battery cable.

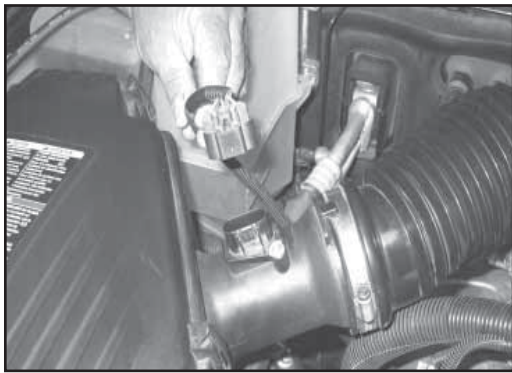

2. Depress the locking tab and disconnect the mass air sensor electrical connection.

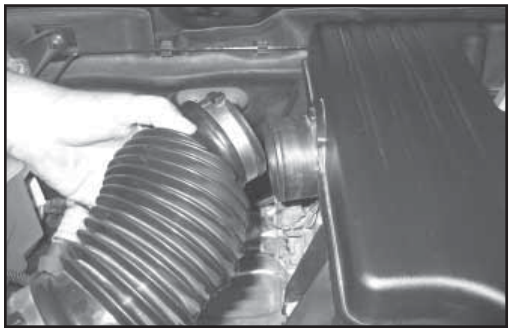

3. Loosen the hose clamp that secures the intake tube to the intake resonator. Disconnect the intake tube from the intake resonator as shown.

Note: On vehicles equipped with an air injection pump; depress the locking ring on the air pump fresh air inlet tube, then disconnect the fresh air inlet tube from the airbox.

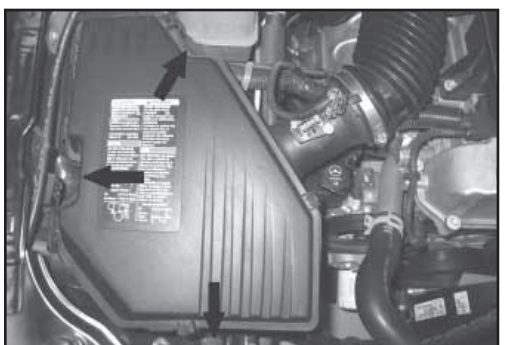

4. Loosen and remove the two air box mounting bolts and one mounting nut as shown. **Note: 2008 and later vehicles are not equipped with the retaining nut. All other vehicles will use the retaining nut in a later step.**

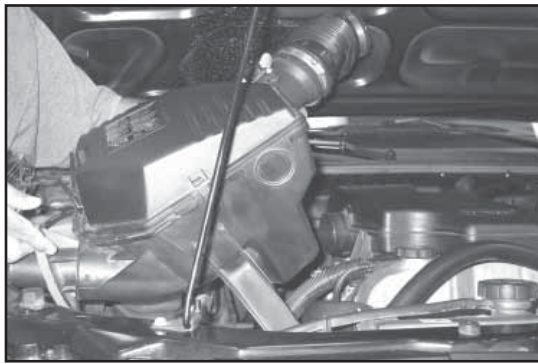

5. Lift the air box up, removing it from the vehicle. **Note: K&N recommends that customers do not discard factory air intake.**



6. Loosen the two intake resonator mounting bolts and hose clamp at the throttle body. **Note: One intake resonator mounting bolt will be re-used.**

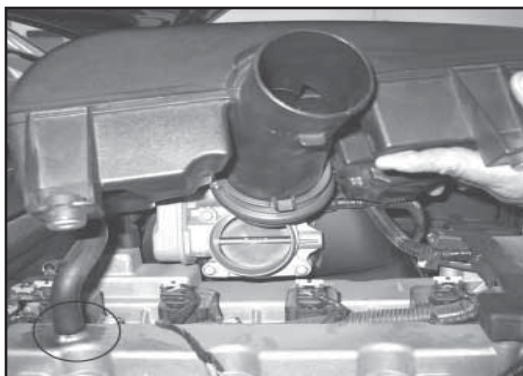

7. Remove the intake resonator from the vehicle as shown. **Note: Disconnect the crank case vent hose from the valve cover while removing the intake resonator from the engine.**

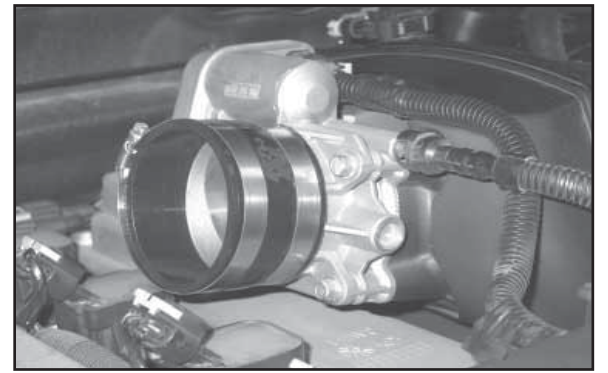

8. Install silicone hose (#08434) onto the throttle body and secure with the provided hose clamp as shown.

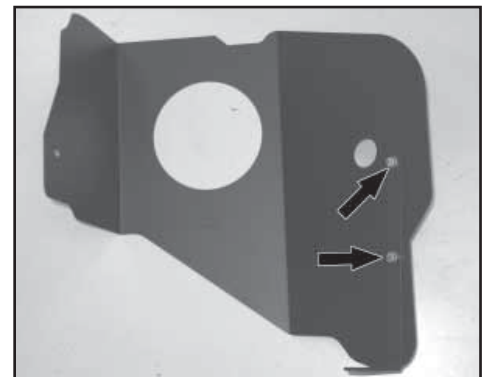

9. Install "L" bracket (#010060) onto the heat shield with the provided hardware as shown.

Note: Use two of the provided spacers between the bracket and heat shield, one on each bolt.

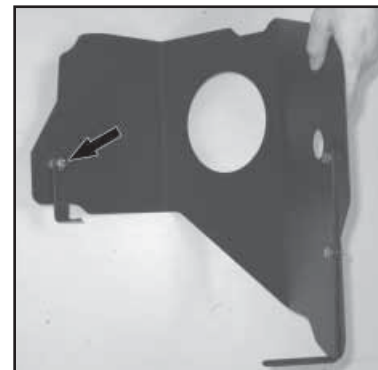

10. Install the small "L" bracket (#070602) onto the heat shield with the provided hardware as shown.

Note: Use one of the provided spacers between the bracket and heat shield.

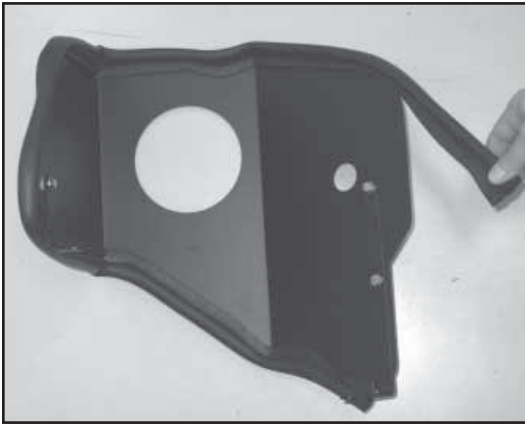

11. Install the edge trim onto the heat shield as shown.

Note: Some trimming of the edge trim may be necessary.



11a. On vehicles that are not equipped with the air box mounting stud and nut, drill out the existing hole in the inner fender with a drill and 1/2" bit.

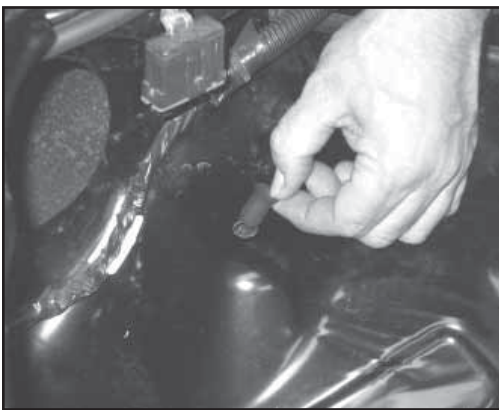

11b. Install the provided insert nut into the hole drilled into the fender in step #11a.



11c. Install the provided adapter into the small heat shield hole as shown.



11d. Install the provided air pump filter onto the adapter installed in the previous step. Secure with the provided hose clamp.

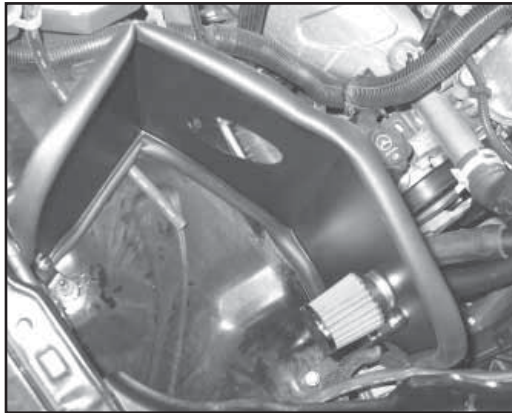

12. Install the heat shield into the vehicle and secure with the provided hardware.

Note: On vehicles equipped with the air box mounting stud, the factory nut will be re-used. The front of the heat shield will secure to the front air box mounting location. The rear of the heat shield will secure to the mounting stud using the factory nut. On 2008 and later vehicles, the rear of the heat shield will secure to the insert nut installed in step #11b.

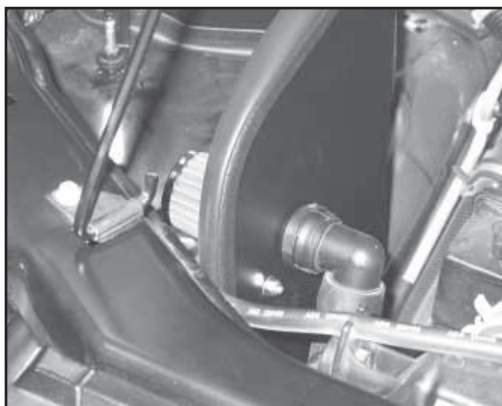

12a. On vehicles equipped with an air injection pump, secure the air injection pump hose to the adapter as shown.

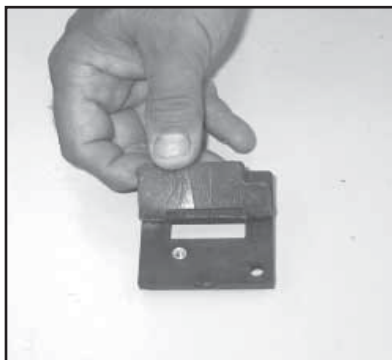

13. Install the provided gasket onto the K&N mass air sensor adapter as shown.

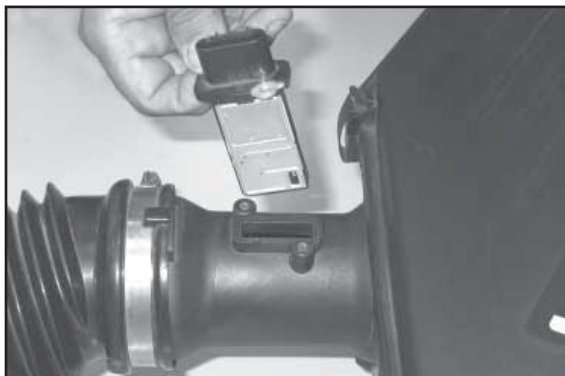

14. Remove the two mass air sensor mounting screws and remove the mass air sensor from the stock air box as shown.

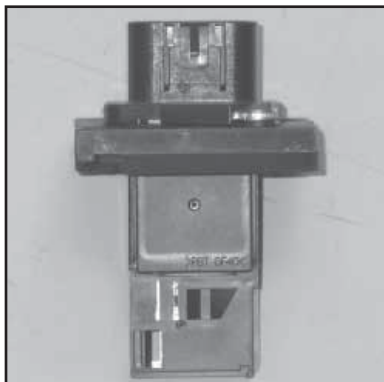

15. Install the mass air sensor into the K&N mass air sensor adapter and secure with the provided hardware as shown.

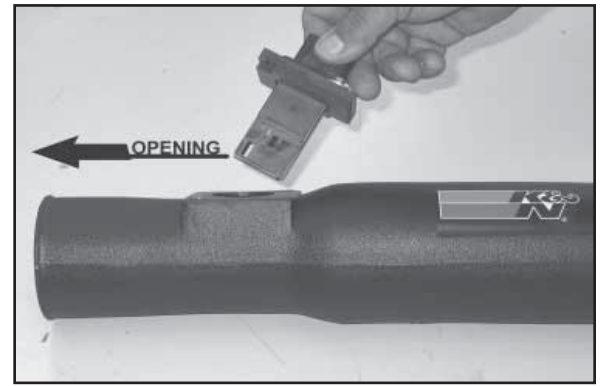

16. Install the mass air sensor assembly into the K&N intake tube and secure with the provided hardware.

Note: The opening in the mass air sensor is to be pointed towards the inlet end of the intake tube.

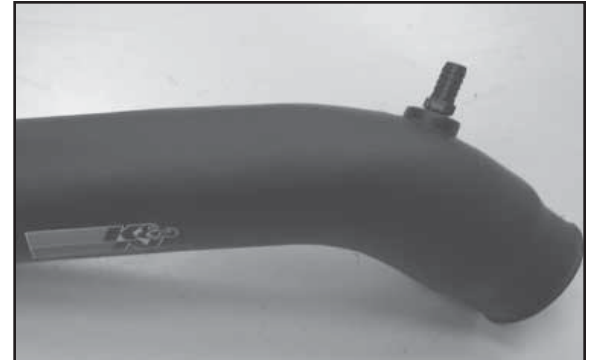

17. Install the provided 1/4" NPT fitting into the K&N intake tube as shown.

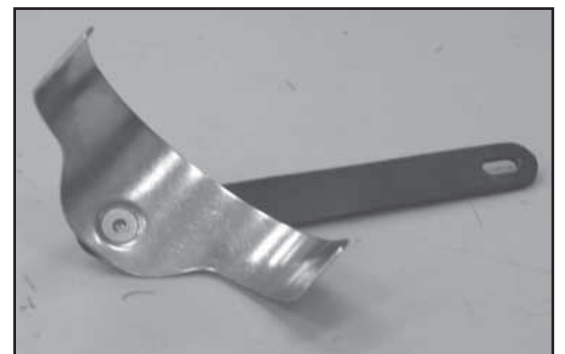

18. Install the saddle clamp onto the tube mounting bracket with the provided hardware.

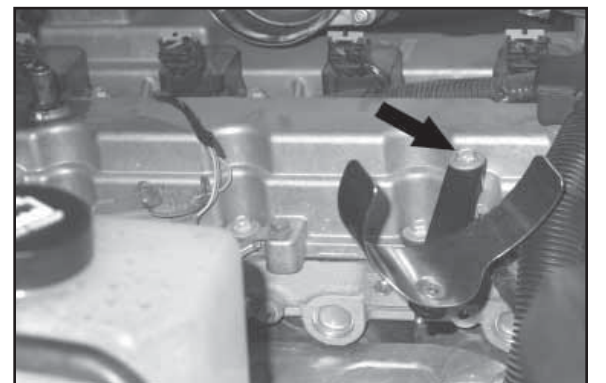

19. Install the tube mounting bracket assembly onto the valve cover. Place the provided large spacer between the bracket and valve cover, and secure with the factory bolt removed in step #6 as shown.



20. Install the K&N intake tube into the silicone hose at the throttle body and align it with the mounting bracket installed in the previous step. Secure the intake tube with the provided hose clamps.

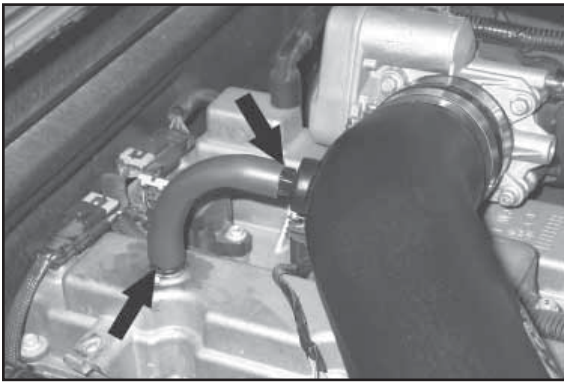

21. Install the provided crank case vent hose onto the valve cover and connect the remaining open end to the K&N intake tube as shown.

Note: Some trimming of the provided crank case vent hose may be necessary.



22. Install the provided air filter adapter into the K&N air filter and secure with the provided hose clamp.



23. Install the silicone hose (#08724) onto the air filter adapter and secure with the provided hose clamp.

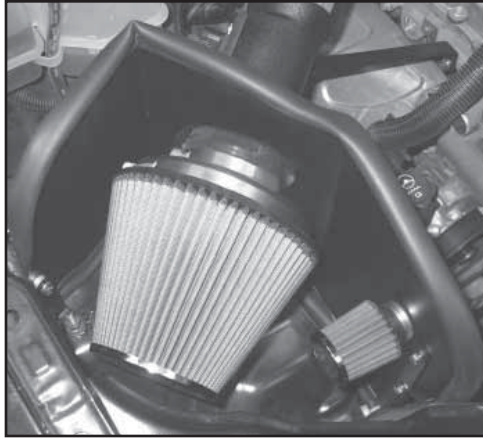

24. Install the air filter assembly onto the K&N intake tube and secure with the provided hose clamp.

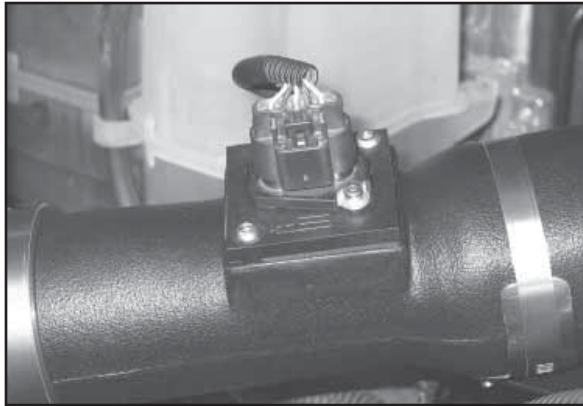

25. Re-connect the mass air sensor electrical connection.

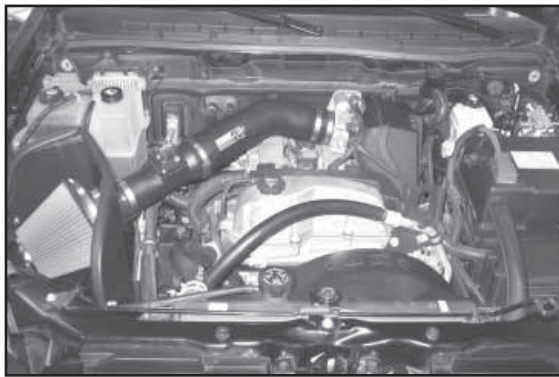

26. Re-connect the vehicle's negative battery cable. Check to ensure everything is tight and properly positioned before starting the vehicle.

27. It will be necessary for all K&N intake kits to be checked periodically for re-alignment, clearance, and tightening of all connections. Failure to follow above installation instructions and/or improper maintenance may void warranty.

Road Testing

1. Start the engine with the transmission in neutral or park, and the parking brake engaged. Listen for air leaks or odd noises. For air leaks secure hoses and connections. For odd noises, find cause and repair before proceeding. This kit will function identically to the factory system except for being louder and much more responsive.

2. Test drive the vehicle. Listen for odd noises or rattles and fix as necessary.

3. If road test is fine, you can now enjoy the added power and performance from your kit.

4. K&N suggests checking the Air filter element periodically for excessive dirt build-up. When the element becomes covered in dirt (or once a year), service it according to the instructions on the Recharger service kit, part number 99-5050 or 99-5000.

STREET LEGAL IN MOST STATES

**NOT LEGAL FOR USE IN CA & OTHER STATES
ADOPTING CA EMISSIONS STANDARDS**

See our catalog or knfilters.com for CARB status on each part for a specific vehicle

FREE K&N DECAL To register your warranty, please see us online at knfilters.com/register. FREE K&N DECAL