



AIRCHARGER™

HIGH-FLOW INTAKE KITS



INSTALLATION INSTRUCTIONS

63-3056
CHEVROLET
2008-10 HHR
L4-2.4L
2010-11 HHR
L4-2.2L

NOTE: This kit was not designed to fit vehicles with a body lift.

TOOLS NEEDED:

Flat Blade Screwdriver
20 Torx Socket
27 Torx Socket
2.5mm Allen Wrench
3mm Allen Wrench
4mm Allen Wrench
7/16" Wrench
Ratchet
Extension

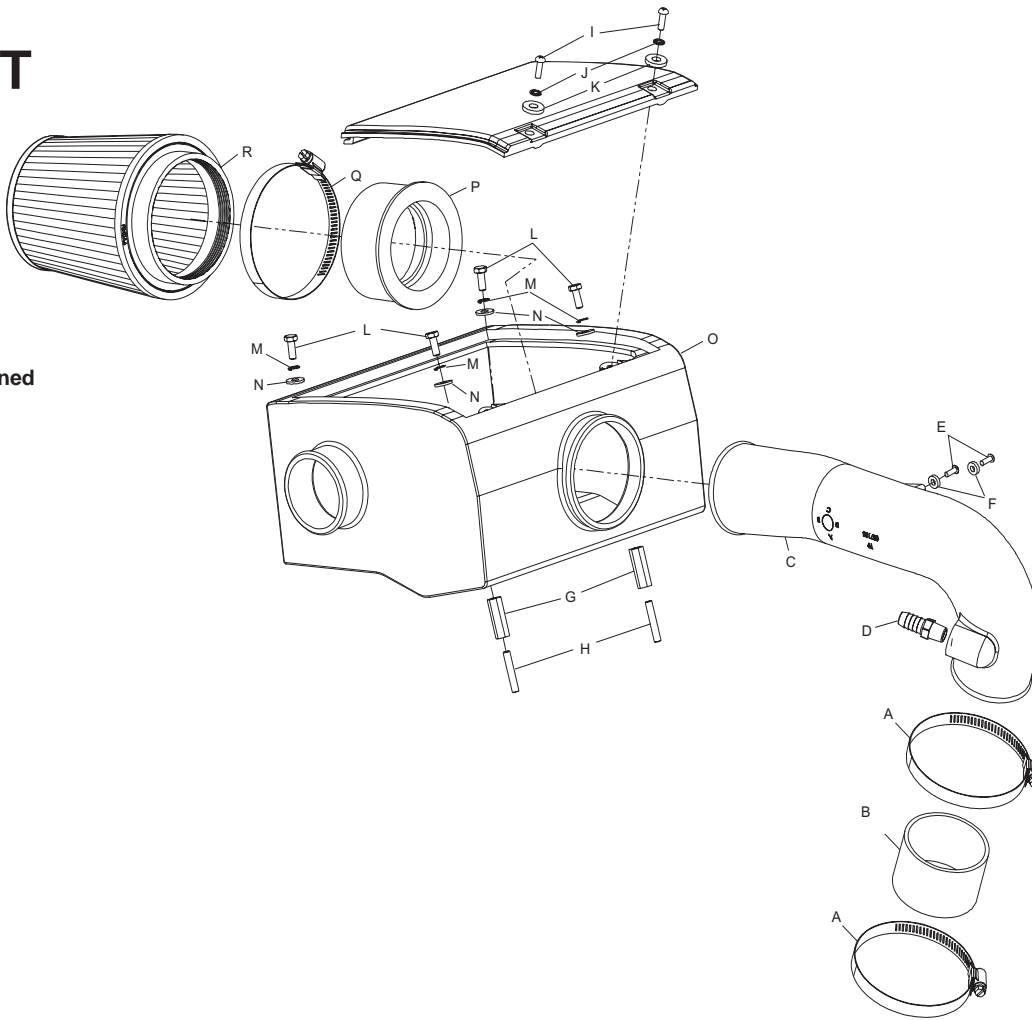

PARTS LIST:

Description	Qty.	Part #
A hose clamp; #44	2	08560
B Hose; 2.75" id X 2" L, silicone	1	08756
C intake tube (FP)	1	087188
D vent; str 1/2" hose, 1/4" npt	1	080022
E bolt; m4-.7x12mm, b/h/a	2	07726
F spacer; .437" o.d. x .200" i.d. x .115" thk	2	06503
G nut; 6mm x 1.33" l, coupling	2	08254
H stud; 6mm-1.00 x 35mm l, ss	2	08220
I screw; 10-32 x 5/8	2	07775
J washer; 5mm internal star, lock	2	07724
K washer; flat #10	2	08257
L bolt; m6 x 1.00 x 16mm	4	07703
M washer; 1/4" split lock	4	08198
N washer; 1/4" id x 5/8" od, flat	4	08275
O airbox (FQ)	1	087189
P filter adapter	1	21561
Q Hose clamp #64	1	08648
R air filter	1	RC-5149

NOTE: FAILURE TO FOLLOW INSTALLATION INSTRUCTIONS AND NOT USING THE PROVIDED HARDWARE MAY DAMAGE THE INTAKE TUBE, THROTTLE BODY AND ENGINE.

TO START:

1. Turn off the ignition and disconnect the negative battery cable.
NOTE: Disconnecting the negative battery cable erases pre-programmed electronic memories. Write down all memory settings before disconnecting the negative battery cable. Some radios will require an anti-theft code to be entered after the battery is reconnected. The anti-theft code is typically supplied with your owner's manual. In the event your vehicles' anti-theft code cannot be recovered, contact an authorized dealership to obtain your vehicles anti-theft code.

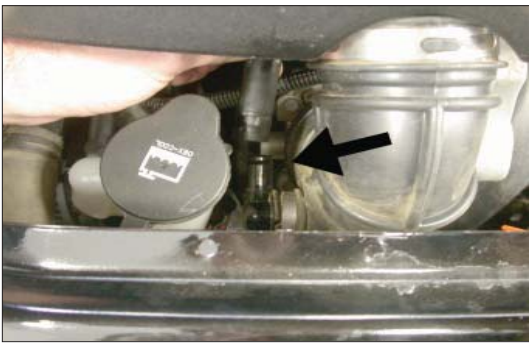

2. Loosen the hose clamp, which secures the crank case vent hose to the stock intake tube, and then disconnect the crank case vent hose from the stock intake tube as shown.



3. Loosen the hose clamp, which secures the intake tube to the throttle body, and then pull up on the intake tube/airbox assembly to dislodge it from the mounting grommets and disconnect the intake tube from the throttle body.



4. Lift the air box assembly up enough to gain access to the fresh air supply hose clamp, then loosen the clamp and disconnect the fresh air supply hose from the air box assembly.

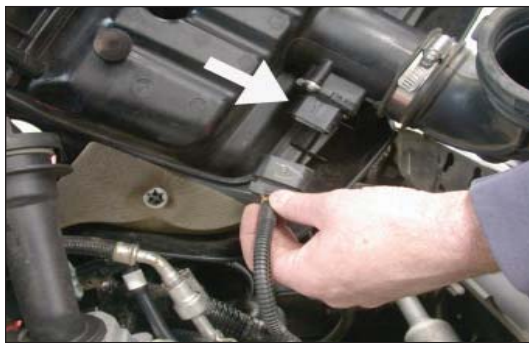

5. Flip the air box assembly up towards the driver's side of the vehicle to gain access to the mass air sensor electrical connection, and then disconnect the mass air sensor electrical connection as shown.



6. Remove the air box assembly from the vehicle.
NOTE: K&N Engineering, Inc., recommends that customers do not discard factory air intake.



7. Remove the two screws securing the mass air sensor to the stock intake tube and then remove the sensor as shown.

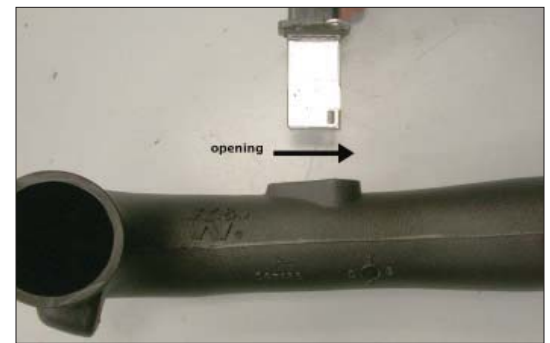

8. Install the mass air sensor into the intake tube as shown.
NOTE: The small opening in the sensor will be pointed towards the filter end of the tube.



9. Secure the mass air sensor to the intake tube with the screws and spacers provided.



10. Install the supplied crank case vent fitting into the intake tube as shown.

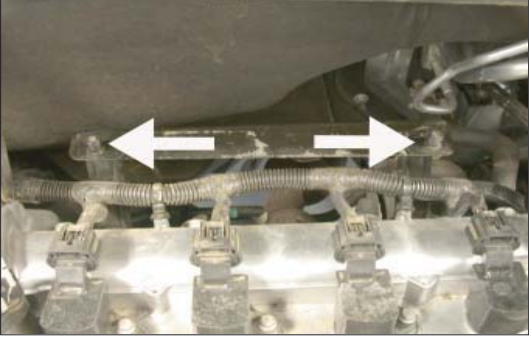

11. Remove the two stock air box mounting anchors shown from the mounting bracket.



12. Install the two supplied 6mm studs into the valve cover as shown.



13. Thread and tighten the two coupling nuts onto the studs installed in step #12.



14. Install the K&N air box onto the engine. Using the supplied hardware, secure the air box to the rear mounting bracket first and then to the coupling nuts installed in step #13.



15. Install the fresh air supply hose onto the K&N air box and secure with the factory hose clamp.



16. Install the silicone hose (08756) onto the throttle body and secure with the provided hose clamp.



17. Install the filter adapter into the K&N filter as shown.



18. Place the filter assembly into the K&N air box as shown.

NOTE: Drycharger® air filter wrap; part # RC-5149DK is available to purchase separately. To learn more about Drycharger® filter wraps or look up color availability please visit <http://www.knfilters.com>®.



19. Install the K&N intake tube through the opening in the air box and into the filter assembly. Then install the intake tube into the silicone hose at the throttle body and secure the filter and tube with the provided hose clamps.



20. Install the stock crank case vent hose onto the fitting on the K&N intake tube and secure with the stock hose clamp.



21. Install the K&N air box lid and secure with the provided hardware as shown.



22. Reconnect the vehicle's mass air sensor electrical connection.



23. Reconnect the vehicle's negative battery cable. Double check to make sure everything is tight and properly positioned before starting the vehicle.

24. It will be necessary for all K&N® high flow intake systems to be checked periodically for realignment, clearance and tightening of all connections. Failure to follow the above instructions or proper maintenance may void warranty.

ROAD TESTING:

1. Start the engine with the transmission in neutral or park, and the parking brake engaged. Listen for air leaks or odd noises. For air leaks secure hoses and connections. For odd noises, find cause and repair before proceeding. This kit will function identically to the factory system except for being louder and much more responsive.

2. Test drive the vehicle. Listen for odd noises or rattles and fix as necessary.

3. If road test is fine, you can now enjoy the added power and performance from your kit.

4. K&N Engineering, Inc., suggests checking the air filter element periodically for excessive dirt build-up. When the element becomes covered in dirt (or once a year), service it according to the instructions on the Recharger® service kit, part number 99-5050 or 99-5000.

STREET LEGAL IN MOST STATES

NOT LEGAL FOR USE IN CA & OTHER STATES ADOPTING CA EMISSIONS STANDARDS

See our catalog or knfilters.com for CARB status on each part for a specific vehicle

* FREE K&N® decal To register your warranty, please see us online at knfilters.com/register. FREE K&N® decal *

• 1455 CITRUS ST., P.O. BOX 1329, RIVERSIDE, CA., U.S.A. 92502 • TECH SERVICE 800-858-3333 • FAX 951-826-4001
• e-mail: tech@knfilters.com • WWW: <http://www.knfilters.com>

18914h
12/2/10