



AIRCHARGER®

INSTALLATION INSTRUCTIONS

63-3052 CHEVROLET 2005-07 CORVETTE V8-6.0L

NOTE: This kit was not designed to fit vehicles with a body lift.

TOOLS NEEDED:

Flat Blade Screwdriver
10mm Wrench

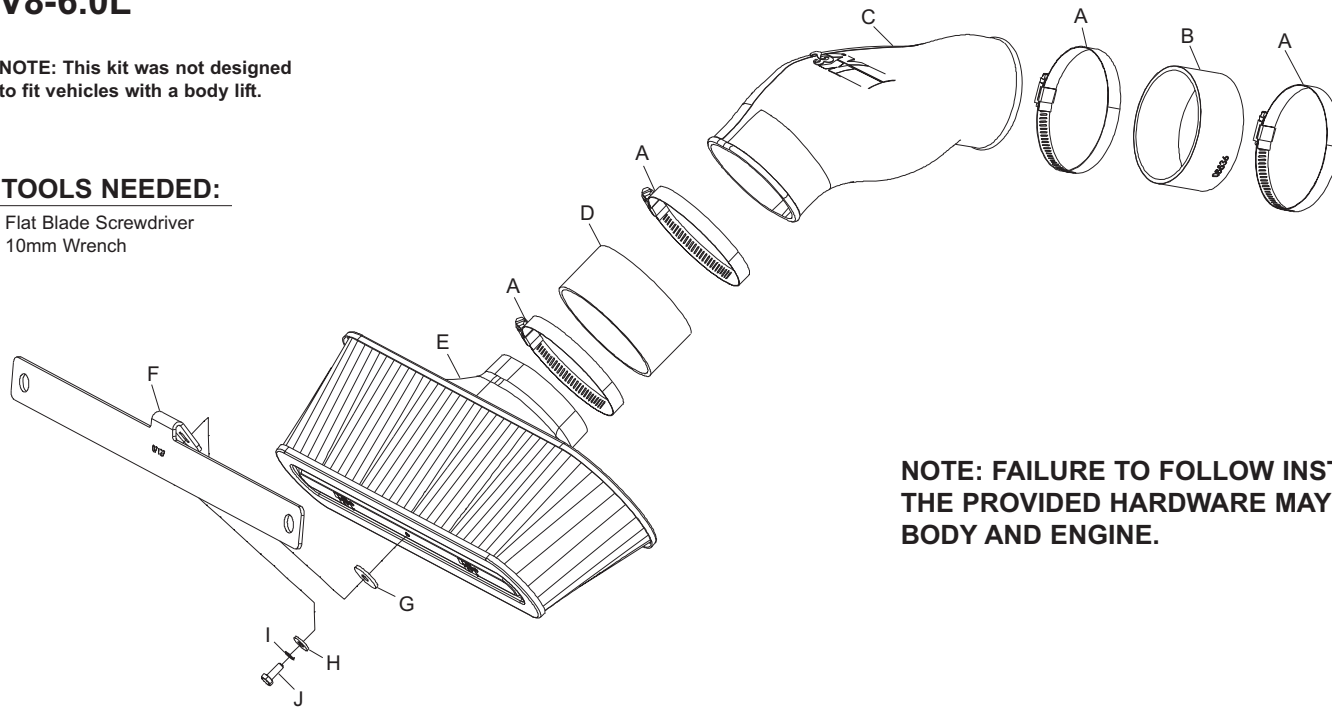

PARTS LIST:

Desc.	QTY.	Part #
A hose clamp #64	4	08645
B hose; 3.75" id x 1.75" L, silicone	1	08536
C intake tube (EZ)	1	087169
D hose; 4" id x 2" L, silicone	1	08625
E air filter	1	RP-5135
F filter bracket	1	010111
G washer; black rubber	1	21685
H washer; 5/8" od x 1/4" id, flat	1	08275
I washer; 1/4" split lock	1	08198
J bolt; 6mm-1.00 x 16mm, hex	1	07703

NOTE: FAILURE TO FOLLOW INSTALLATION INSTRUCTIONS AND NOT USING THE PROVIDED HARDWARE MAY DAMAGE THE INTAKE TUBE, THROTTLE BODY AND ENGINE.

TO START:

1. Turn the ignition OFF and disconnect the vehicle's negative battery cable.



2. Unsnap the ends and then remove the air filter cover as shown.

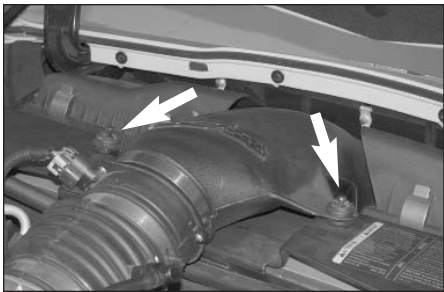

3. Loosen the hose clamp which secures the stock intake tube to the mass air sensor, then pull up to release the center locking pins in the intake tube mounting fasteners shown.



4. Pull up on the complete intake system to disconnect it from the air box mounting pins and then remove it from the vehicle as shown.

K&N recommends that you do not discard your factory air intake.

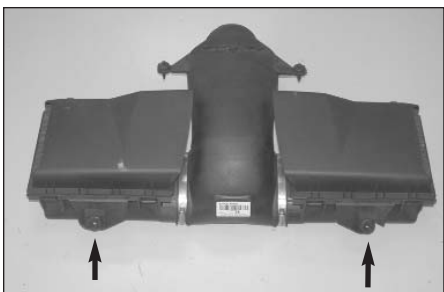

5. Remove the two rubber mounting grommets shown air box as shown.

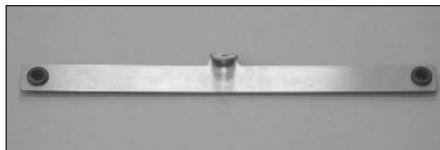

6. Install the two rubber mounting grommets from step #5 into the filter-mounting brackets as shown.



7. Install the silicone hose (08625) onto the air filter as shown and secure with the provided hose clamps.



8. Install the K&N intake tube onto the air filter as shown and secure with the provided hose clamp.



9. Install the silicone hose (08536) onto the K&N intake tube and secure with the provided hose clamps.



10. Install the air filter mounting bracket onto the air filter as shown and secure with the provided hardware.

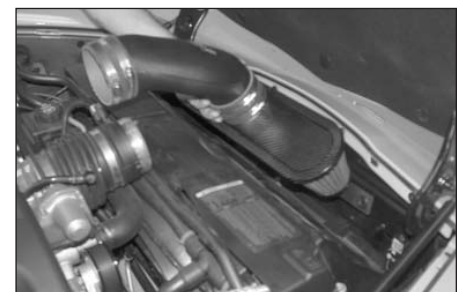

11. Install the intake kit assembly into the vehicle as shown.



12. Snap the filter-mounting bracket onto the filter as shown and secure with the provided hardware.



13. Install the intake kit onto the mass air sensor secure with the provided hose clamp.



14. Reconnect the vehicle's negative battery cable. Double check to make sure everything is tight and properly positioned before starting the vehicle.

15. It will be necessary for all Aircharger's to be checked periodically for realignment, clearance and tightening of all connections. Failure to follow the above instructions or proper maintenance may void warranty.

ROAD TESTING:

1. Start the engine with the transmission in neutral or park, and the parking brake engaged. Listen for air leaks or odd noises. For air leaks secure hoses and connections. For odd noises, find cause and repair before proceeding. This kit will function identically to the factory system except for being louder and much more responsive.

2. Test drive the vehicle. Listen for odd noises or rattles and fix as necessary.

3. If road test is fine, you can now enjoy the added power and performance from your kit.

4. K&N suggests checking the air filter element periodically for excessive dirt build-up. When the element becomes covered in dirt (or once a year), service it according to the instructions on the Recharger service kit, part number 99-5050 or 99-5000.