



# AIRCHARGER® HIGH-FLOW INTAKE KITS

## INSTALLATION INSTRUCTIONS

### 63-3030

#### Chevrolet/GMC

2007 Classic Silverado 2500HD, 3500

2007 Classic Sierra 2500HD, 3500

V8-8.1L

Note: This kit was not designed to fit vehicles with a body lift.

#### TOOLS NEEDED:

10mm Wrench  
4mm Allen Wrench  
Flat Blade Screwdriver

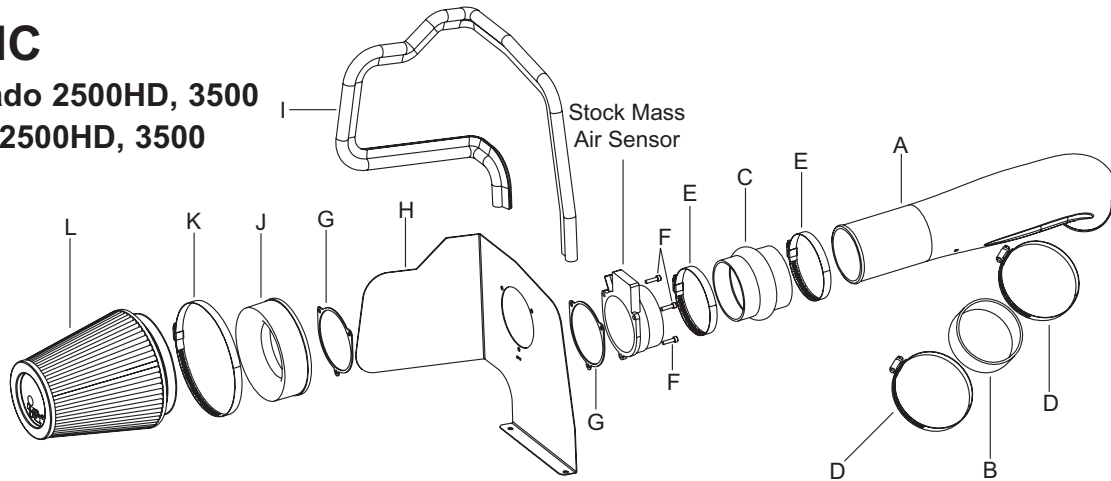

#### PARTS LIST:

Desc.	Part #	QTY.
A Intake Tube	087014	1
B Silicone Hose	08755	1
C Hump Hose	08176	1
D Hose Clamp #64 MIDI	08650	2
E Hose Clamp #60	08624	2
F Bolt, 5mm-.80x20mm Allen	08320	3
G Gasket	09033	2
H Heat Shield	07439	1
I Edge Trim 48"L	102485	1
J Adaptor	08783	1
K Hose Clamp #104	08697	1
L Air Filter	RF-1041	1

**NOTE: FAILURE TO FOLLOW INSTALLATION INSTRUCTIONS AND NOT USING THE PROVIDED HARDWARE MAY DAMAGE THE INTAKE TUBE, THROTTLE BODY AND ENGINE.**

#### TO START:

1. Turn the ignition OFF and disconnect the vehicle's negative battery cable.



2. Disconnect the vehicle's mass air sensor.



3. Loosen the hose clamps at the throttle body and at the mass air sensor, then, remove the factory intake tube.



4. Pull firmly upward to release the air cleaner from its mounting grommets, then, remove the air cleaner assembly.

**NOTE: K&N recommends that customers do not discard factory air intake.**

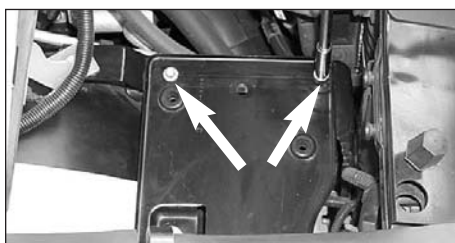

5. Loosen and remove the two air cleaner mounting tray bolts as shown.



6. Loosen the hose clamp on the mass air sensor, then, remove the mass air sensor.

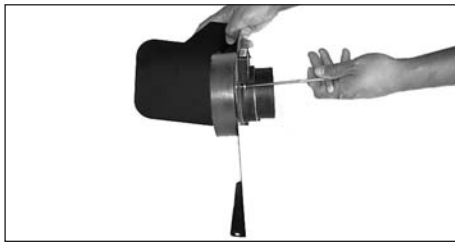

7. Assemble the mass air sensor, gaskets, heat shield and mass air adapter with the provided hardware as shown.



8. Apply the trim seal to the heat shield assembly as shown.

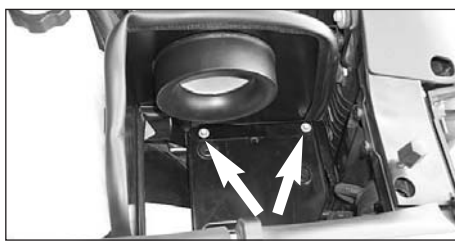

9. Install and mount the heat shield assembly to the air cleaner mounting tray using the bolts removed in step 5.



10. Install the silicone hose and hose clamps onto the throttle body as shown.



11. Install the silicone hump hose and hose clamps onto the mass air sensor as shown.



12. Slide the K&N intake into the hump hose at the mass air sensor, then, slide the tube into the silicone hose at the throttle body and tighten the hose clamps.



13. Install the K&N air filter onto the mass air adapter and secure it with the provided hose clamp.



14. Reconnect the vehicle's mass air sensor.



15. Reconnect the vehicle's negative battery cable. Double check to make sure everything is tight and properly positioned before starting the vehicle.

16. It will be necessary for all Aircharger's to be checked periodically for realignment, clearance and tightening of all connections. Failure to follow the above instructions or proper maintenance may void warranty.

#### ROAD TESTING:

1. Start the engine with the transmission in neutral or park, and the parking brake engaged. Listen for air leaks or odd noises. For air leaks secure hoses and connections. For odd noises, find cause and repair before proceeding. This kit will function identically to the factory system except for being louder and much more responsive.

2. Test drive the vehicle. Listen for odd noises or rattles and fix as necessary.

3. If road test is fine, you can now enjoy the added power and performance from your kit.

4. K&N suggests checking the air filter element periodically for excessive dirt build-up. When the element becomes covered in dirt (or once a year), service it according to the instructions on the Recharger service kit, part number 99-5050 or 99-5000.

\*FREE K&N DECAL To register your warranty, please see us online at [knfilters.com/register](http://knfilters.com/register). FREE K&N DECAL\*