



AIRCHARGER™

HIGH-FLOW INTAKE KITS

INSTALLATION INSTRUCTIONS

63-2566

FORD 2008-09 MUSTANG V6-4.0L

NOTE: This kit was not designed to fit vehicles with a body lift.

TOOLS NEEDED:

Flat Blade Screwdriver
Ratchet
Extension
8mm Socket
10mm Socket
15mm Socket
10mm Wrench

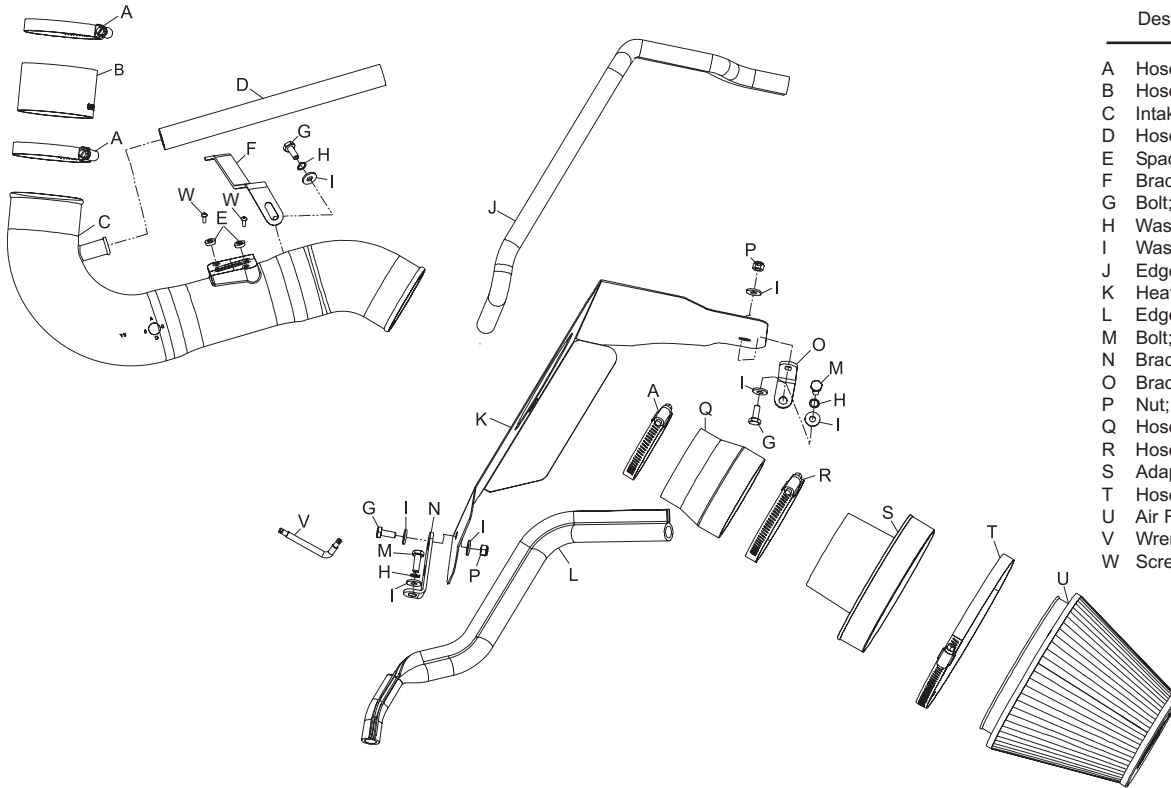

PARTS LIST:

Description	Qty.	Part #
A Hose Clamp #48	3	08601
B Hose; Straight, Black Silicone	1	08434
C Intake Tube (ey)	1	087168
D Hose; 5/8"ID x 9.75"L, Silicone	1	084047
E Spacer; .437"OD x .2"ID x .115"Thk	2	06503
F Bracket	1	010110
G Bolt; 6mm-1.00 x 16mm, Hex	3	07703
H Washer; 1/4" Split Lock	3	08198
I Washer; 1/4"ID x 5/8"OD, Flat	7	08275
J Edge Trim 30"	1	102489
K Heat Shield	1	074038
L Edge Trim 23"	1	102495
M Bolt; 6mm-1.00 x 25mm, Hex	2	07704
N Bracket, "L"	1	07158
O Bracket, "L"	1	070812
P Nut; 6mm Nylock	2	07553
Q Hose; Step, Black Silicone	1	08724
R Hose Clamp; #56	1	08620
S Adapter #452	1	21518
T Hose Clamp; #104	1	08697
U Air Filter	1	RF-1048
V Wrench, T20 "L" Key	1	69801
W Screw; M4-.7 X 16mm, Button SS	2	07793

NOTE: FAILURE TO FOLLOW INSTALLATION INSTRUCTIONS AND NOT USING THE PROVIDED HARDWARE MAY DAMAGE THE INTAKE TUBE, THROTTLE BODY AND ENGINE.

TO START:

1. Turn the ignition OFF and disconnect the vehicle's negative battery cable.



2. Release the red locking tab and then disconnect the mass air sensor electrical connection.



3. Disconnect the crank case vent hose from the stock intake tube as shown.



4. Loosen the hose clamps, which secure the intake tube to the throttle body and air box, then remove the intake tube as shown.

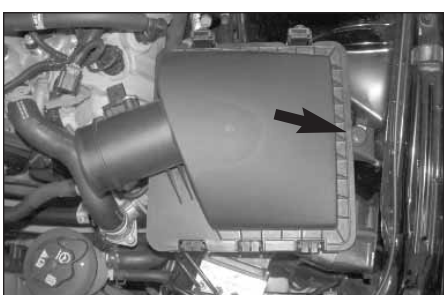

5. Remove the air box mounting bolt shown.



6. Remove the air box assembly as shown.
NOTE: K&N Engineering, Inc., recommends that customers do not discard factory air intake.



7. Remove the power steering pump bracket-retaining nut shown.
NOTE: Nut will be reused.



8. Install the tube-mounting bracket onto the power steering mounting bracket stud and secure with the nut removed in step #7.
NOTE: Do not completely tighten at this time.

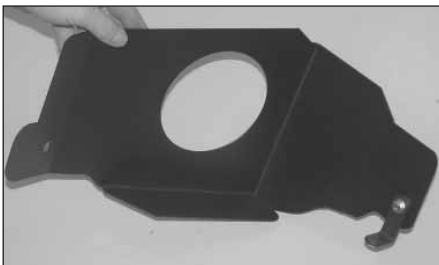

9. Install the "L" bracket (070812) onto the rear of the heat shield as shown with the provided hardware.

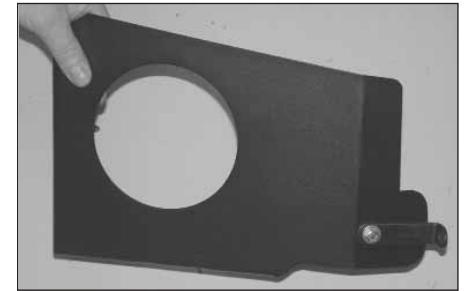

10. Install the "L" bracket (07158) onto the front of the heat shield as shown with the provided hardware.



11. Install the edge trim onto the heat shield as shown.
NOTE: some trimming of the edge trim may be necessary for proper fit.



12. Remove the radiator fan shroud mounting bolt shown.
NOTE: This bolt will not be reused.



13. Install the heat shield and secure with the provided hardware as shown.
NOTE: The forward mounting bracket will mount to the radiator fan shroud mounting location and the rear bracket will mount to the air box mounting location.

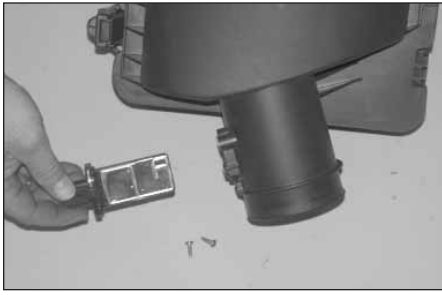

14. Remove the mass air sensor from the factory air box with the T20 "TORX" wrench provided.



15. Install the mass air sensor into the K&N® intake tube with the mounting screws and two spacers provided.

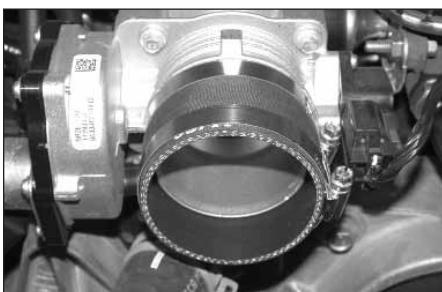

16. Install the silicone hose (08434) onto the throttle body with the provided hose clamps as shown.



17. Install the K&N® intake tube into the silicone hose at the throttle body and onto the tube-mounting bracket installed in step #8, secure with provided hardware.



18. Using a razor blade cut the crank case vent tube 6" from the end as shown.



19. Install the provided crank case vent hose onto the K&N® intake tube and factory vent hose as shown.



20. Install the air filter onto the filter adapter and secure with the provided hose clamp as shown.



21. Install the silicone hose (08724) onto the air filter assembly and secure with the provided hose clamp as shown.



22. Install the air filter assembly onto the K&N® intake tube as shown and secure with the provided hose clamp.



23. Reconnect the mass air sensor electrical connection as shown.



24. Reconnect the vehicle's negative battery cable. Double check to make sure everything is tight and properly positioned before starting the vehicle.

25. It will be necessary for all K&N® high flow air intake's to be checked periodically for realignment, clearance and tightening of all connections. Failure to follow the above instructions or proper maintenance may void warranty.

ROAD TESTING:

1. Start the engine with the transmission in neutral or park, and the parking brake engaged. Listen for air leaks or odd noises. For air leaks secure hoses and connections. For odd noises, find cause and repair before proceeding. This kit will function identically to the factory system except for being louder and much more responsive.
2. Test drive the vehicle. Listen for odd noises or rattles and fix as necessary.
3. If road test is fine, you can now enjoy the added power and performance from your kit.
4. K&N Engineering, Inc., suggests checking the air filter element periodically for excessive dirt build-up. When the element becomes covered in dirt (or once a year), service it according to the instructions on the Recharger® service kit, part number 99-5050 or 99-5000.