



INSTALLATION INSTRUCTIONS

63-1114

DODGE / CHRYSLER

- 2009-10 Challenger
- 2008-10 Charger RT
- 2008-10 300C RT
- 2008 Magnum RT
- V8-5.7L HEMI
- 2008-10 Challenger
- 2008-10 Charger SRT8
- 2008-10 300C SRT8
- 2008 Magnum SRT8
- V8-6.1L HEMI

TOOLS NEEDED:

- 4mm allen
- 3/4" drill bit
- 10mm socket
- 13mm socket
- 10mm wrench
- drill
- flat blade screwdriver
- hack saw
- ratchet

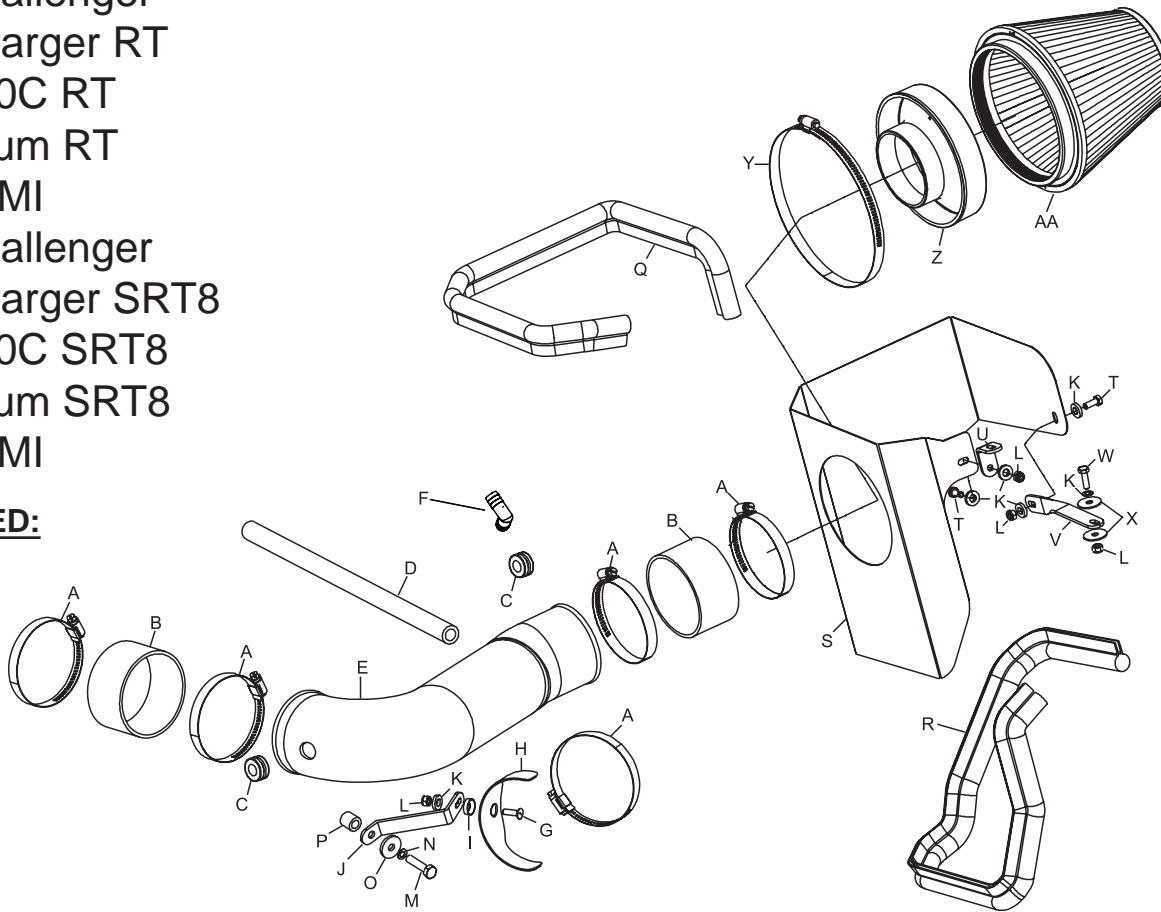

PARTS LIST:

Description	Qty.	Part #
A	5	08620
B	2	08630
C	2	08064
D	1	08177
E	1	087153
F	1	08065
G	1	08376
H	1	078855
I	1	08180
J	1	010088
K	6	08275
L	4	07553
M	1	07784
N	1	08239
O	1	08276
P	1	07849
Q	1	102489
R	1	102496
S	1	07498
T	2	07703
U	1	070066
V	1	070772
W	1	07865
X	2	08160
Y	1	08697
Z	1	21512
AA	1	RF-1042

NOTE: FAILURE TO FOLLOW INSTALLATION INSTRUCTIONS AND NOT USING THE PROVIDED HARDWARE MAY DAMAGE THE INTAKE TUBE, THROTTLE BODY AND ENGINE.

TO START:

1. Turn off the ignition and disconnect the negative battery cable.



2. Lift up on the engine cover to loosen it from the mounts, and then remove the cover from the vehicle.

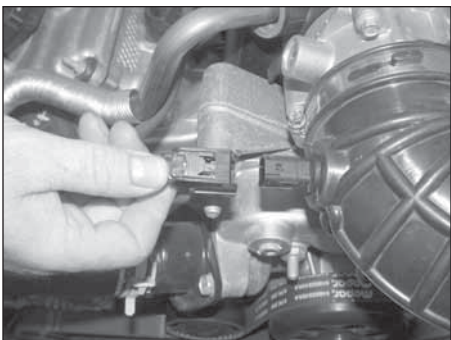

3. Unlock the red locking tab on the air temperature sensor electrical connection, then depress the locking lever and pull apart the temperature sensor electrical connection.



4. Loosen the hose clamp that secures the intake tube to the throttle body and pull the intake tube off of the throttle body.

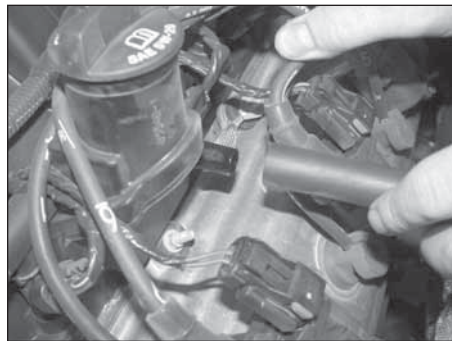

5. Disconnect the crank case vent hose from the valve cover port as shown.

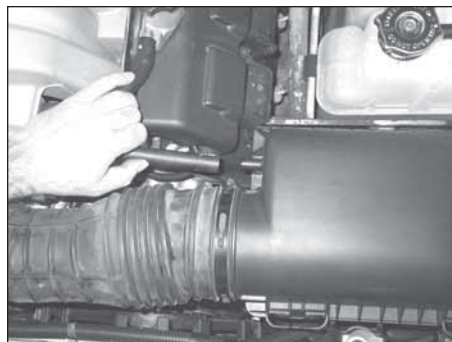

5a. On SRT-8; 6.1L vehicles, disconnect the crank case vent hose from the air box as shown.

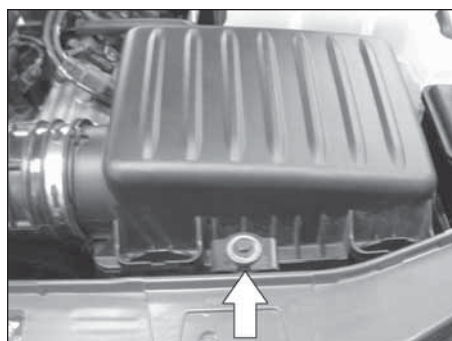

6. Loosen and remove the air box mounting bolt as shown.

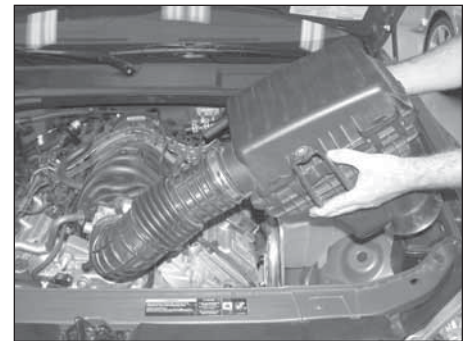

7. Lift the complete intake and air filter assembly to remove it from the vehicle.

NOTE: K&N Engineering, Inc., recommends that customers do not discard factory air intake.



8. Install the twist bracket (070772) onto the core support using the hardware provided through the existing hole as shown.

NOTE: Use the two fender washers provided to sandwich the core support. Do not completely tighten at this time. On vehicles equipped with HID head lights, it will be necessary to install the mounting bolt from the bottom, this may be difficult but it will fit.



9. Install the "L" bracket (070066) onto the heat shield with the provided hardware through the non-slotted hole in the bracket.

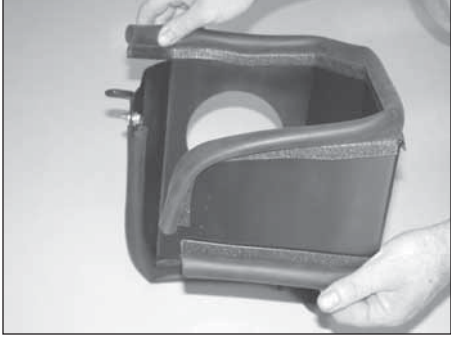

10. Install the two pieces of edge trim onto the heat shield as shown, be sure to leave a gap at the bracket mounting locations.

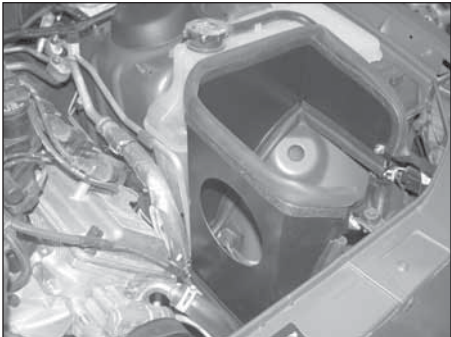

11. Install the heat shield assembly into the vehicle and secure to the bracket installed in step #8. Then secure the "L" bracket with the factory bolt removed in step #6 to the air box mounting location.



12. Assemble the tube mounting bracket and saddle clamp as shown with the provided hardware.

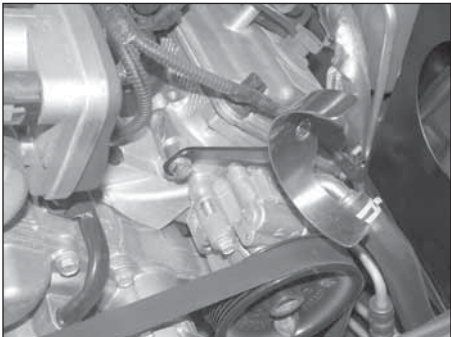

13. Using the provided spacer, install the tube mounting bracket assembly onto the engine as shown.

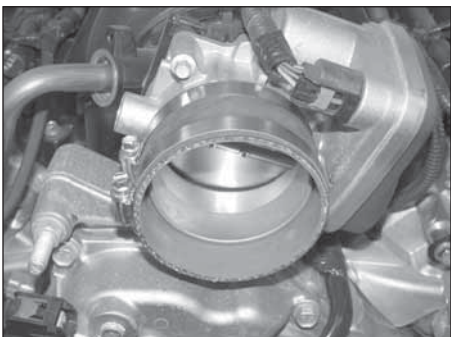

14. Install the silicone hose (08630) onto the throttle body and secure with the provided hose clamp as shown.

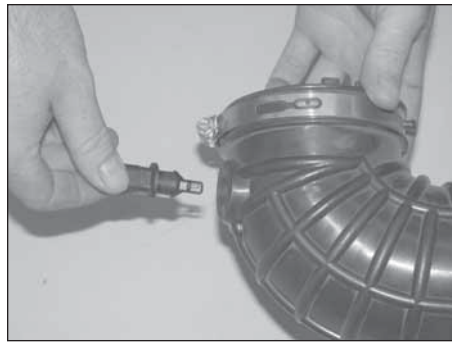

15. Remove the air temperature sensor from the factory intake tube.

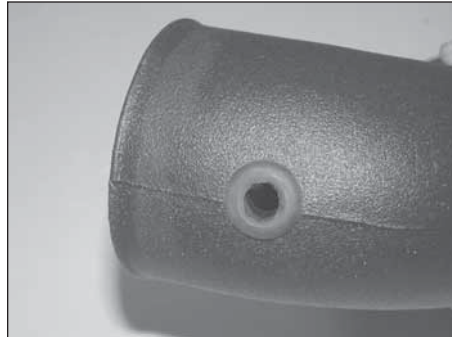

16. Install the provided grommet into the K&N® intake tube as shown.



16a. On SRT 8; 6.1L vehicles, cut the vent off of the K&N® intake tube as shown.



16b. Drill out the hole in the intake tube to 0.75".

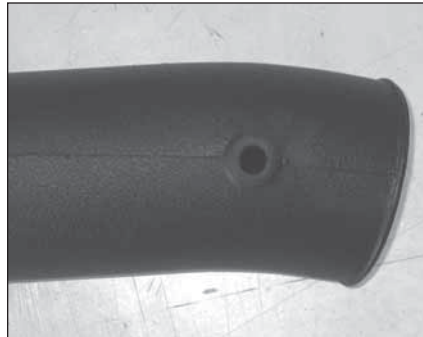

16c. On SRT 8; 6.1L equipped vehicles, install the provided grommet into the 0.75" ID hole as shown.



16d. On SRT 8; 6.1L equipped vehicles, install the provided 90° hose mender as shown.



17. Install the factory air temperature sensor into the grommet installed in step #16.



18. Install the K&N® intake tube into the throttle body and onto the saddle clamp as shown, then secure with the hose clamps provided.

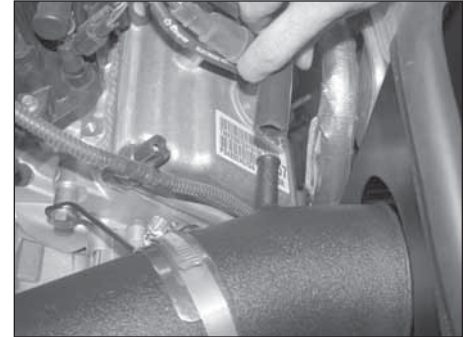

19. Install the provided crankcase vent hose onto the vent port on the valve cover then install the vent hose onto the K&N® intake tube.



19a. On SRT 8; 6.1L equipped vehicles, connect the factory crank case vent hose onto the 90° fitting installed into the K&N® intake tube (in step #16c).



20. Install the filter adapter into the air filter and secure with the provided hose clamp.



21. Install silicone hose (08630) onto the air filter assembly and secure with the provided hose clamp.

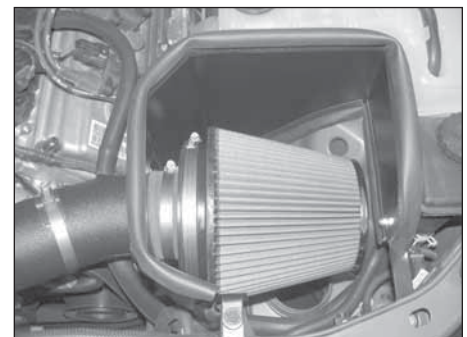

22. Install the air filter assembly onto the K&N® intake tube and secure with the provided hose clamp as shown.

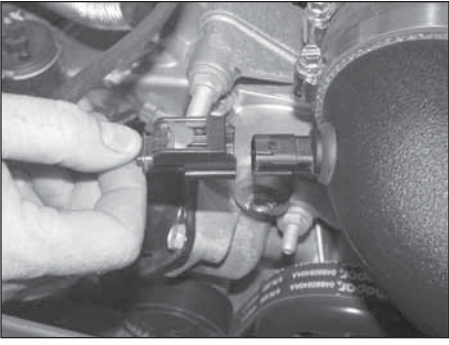

23. Reconnect the air temperature sensor electrical connection as shown.

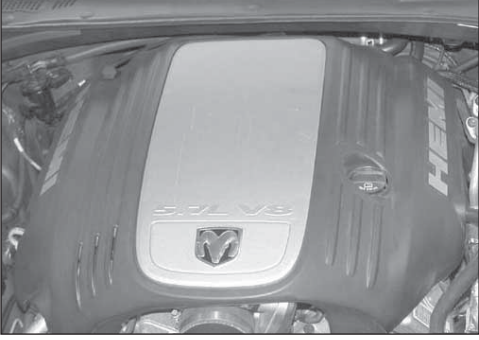

24. Reinstall the engine cover removed in step #2.

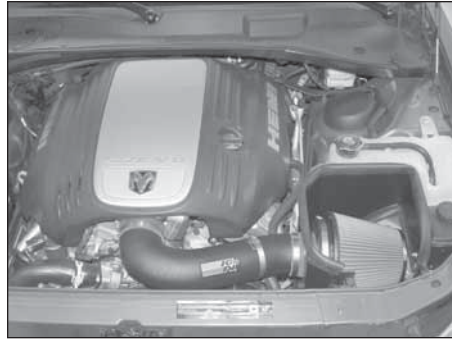

25. Reconnect the vehicle's negative battery cable. Double check to make sure everything is tight and properly positioned before starting the vehicle.

26. It will be necessary for all K&N® high flow intake systems to be checked periodically for realignment, clearance and tightening of all connections. Failure to follow the above instructions or proper maintenance may void warranty.

ROAD TESTING:

1. Start the engine with the transmission in neutral or park, and the parking brake engaged. Listen for air leaks or odd noises. For air leaks secure hoses and connections. For odd noises, find cause and repair before proceeding. This kit will function identically to the factory system except for being louder and much more responsive.
2. Test drive the vehicle. Listen for odd noises or rattles and fix as necessary.
3. If road test is fine, you can now enjoy the added power and performance from your kit.
4. K&N Engineering, Inc., suggests checking the air filter element periodically for excessive dirt build-up. When the element becomes covered in dirt (or once a year), service it according to the instructions on the Recharger® service kit, part number 99-5050 or 99-5000.