



AIRCHARGER™

HIGH-FLOW INTAKE KITS



INSTALLATION INSTRUCTIONS

63-1108
FORD / MAZDA
2008-11 RANGER
2008-09 B4000
V6-4.0L

NOTE: This kit was not designed to fit vehicles with a body lift.

TOOLS NEEDED:

Flat Blade Screwdriver
Ratchet
Extension
7mm Socket
10mm Socket
10mm Wrench

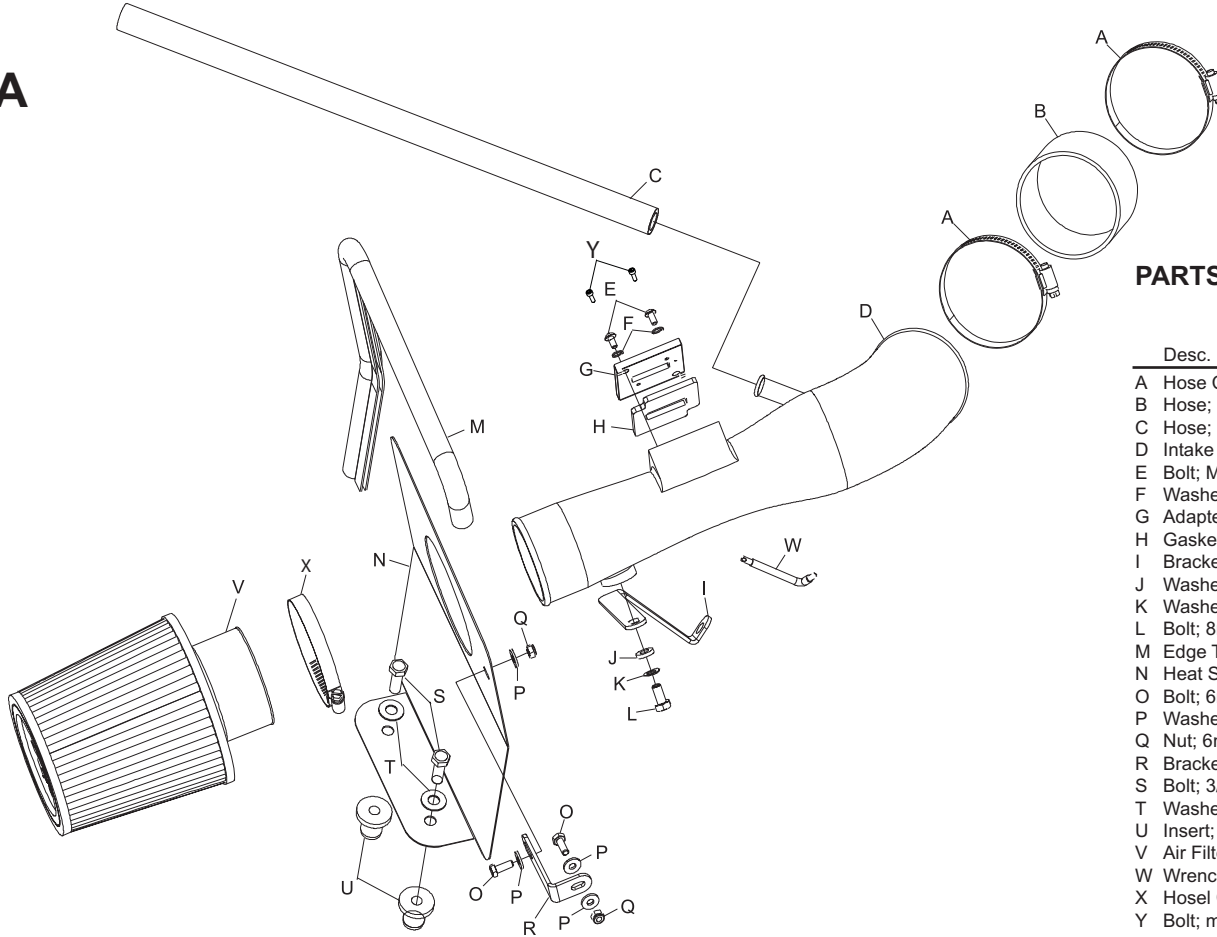

PARTS LIST:

Desc.	Qty.	Part #
A Hose Clamp #56	2	08620
B Hose; 3.5"IDx2.0"L, Black Silicone	1	08630
C Hose; 5/8"IDx20"L, Black Silicone	1	08542
D Intake Tube	1	087133
E Bolt; M6-1.00x16mm, B/H/A	2	07730
F Washer; 1/4" Split Lock	2	08198
G Adapter #420	1	21515
H Gasket; 3/16" Poron	1	09069
I Bracket; "L" Large	1	010081
J Washer; 5/16"ID x 5/8"OD Flat	1	08276
K Washer; 8mm Wave	1	08239
L Bolt; 8mm-1.25 x 16mm, Hex	1	07844
M Edge Trim 26"	1	102488
N Heat Shield	1	07488
O Bolt; 6mm-1.00x16mm Hex	2	07795
P Washer; 1/4"ID x 5/8"OD Flat	4	08275
Q Nut; 6mm Nylock	2	07553
R Bracket; "L" Small	1	070742
S Bolt; 3/8"-16x1.25", Hex	2	07779
T Washer; 3/8" Flat	2	08134
U Insert; 3/8"-16x3/4"x15/16"L Rubber	2	08163
V Air Filter	1	RU-4990
W Wrench, T20 T/R, L-Key	1	69801
X Hosel Clamp #52	1	08610
Y Bolt; m4-0.07-8mm Cap	2	07733

NOTE: FAILURE TO FOLLOW INSTALLATION INSTRUCTIONS AND NOT USING THE PROVIDED HARDWARE MAY DAMAGE THE INTAKE TUBE, THROTTLE BODY AND ENGINE.

TO START:

1. Turn the ignition OFF and disconnect the vehicle's negative battery cable.

NOTE: Disconnecting the negative battery cable erases pre-programmed electronic memories. Write down all memory settings before disconnecting the negative battery cable. Some radios will require an anti-theft code to be entered after the battery is reconnected. The anti-theft code is typically supplied with your owner's manual. In the event your vehicles' anti-theft code cannot be recovered, contact an authorized dealership to obtain your vehicles anti-theft code.



2. Depress the locking tab on the mass air sensor electrical connection and then disconnect the electrical connection and separate the harness from the stock intake tube wiring harness clip.

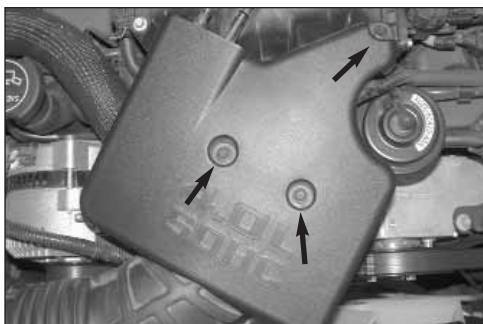

3. Remove the three- engine cover mounting bolts shown.



4. Remove the engine cover from the engine.



5. Depress the green locking tab on the crankcase vent hose attached to the valve cover of the engine and then disconnect the vent hose from the valve cover as shown.



6. Loosen the hose clamp which secures the intake tube to the throttle body, release the two clam shell clamps which secure the upper airbox lid and then remove the airbox lid and intake tube from the vehicle.



7. Pull firmly up on the lower airbox housing to dislodge from the mounting grommets and remove lower airbox from the vehicle.
NOTE: K&N Engineering, Inc., recommends that customers do not discard factory air intake.

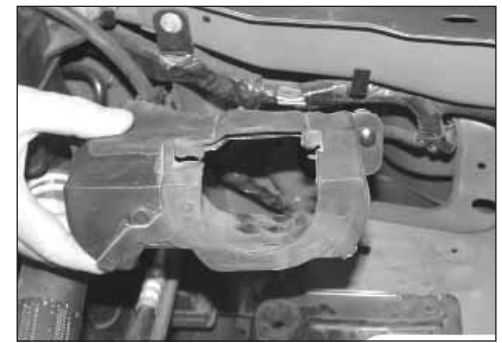

8. Pull firmly on the air duct to dislodge it from core support and remove from the vehicle.



9. Remove the two airbox mounting grommets from the mounting plate shown.



10. Install the silicone hose (08630) onto the throttle body and secure with the provided hose clamp.



11. Using the "TORX" wrench provided, remove the mass air sensor from the stock airbox assembly as shown.

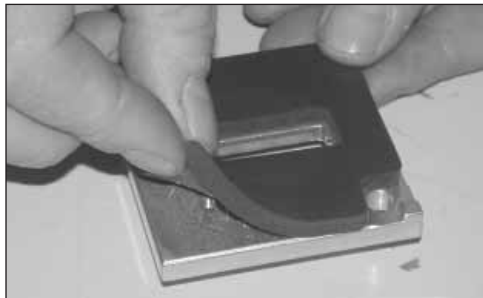

12. Install the provided gasket onto the K&N® mass air adapter as shown. Sticky side down.

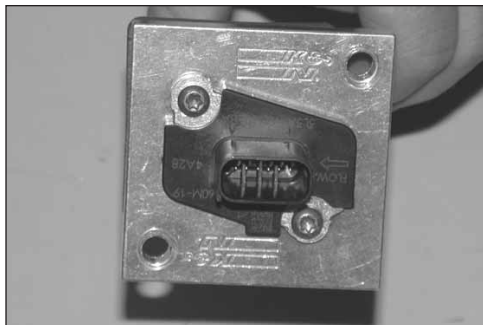

13. Using the provided mounting bolts, install mass air sensor into the K&N® adapter assembly as shown.

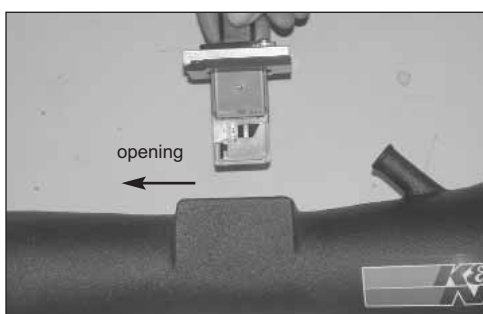

14. Install the mass air sensor assembly into the K&N® intake tube as shown.

NOTE: Make sure the open end of the sensor is towards the filter end of the tube.



15. Secure the mass air assembly onto K&N® intake tube using the hardware provided as shown.



16. Install the provided tube-mounting bracket (010081) onto the K&N® intake tube with the provided hardware as shown.

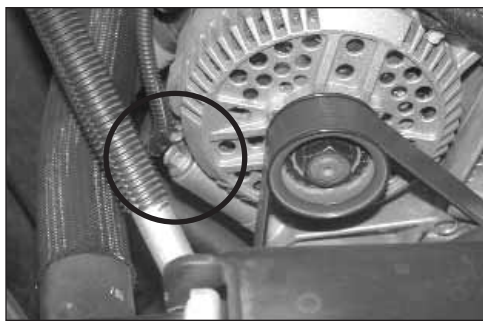

17. Remove the front lower alternator mounting bolt shown.



18. Install the K&N® intake tube into the silicone hose at the throttle body and secure the bracket in place on the alternator with the bolt removed in step #17.



19. Install the heat shield mounting bracket (070742) onto the heat shield with the provided hardware as shown.



20. Install the provided edge trim onto the heat shield as shown.

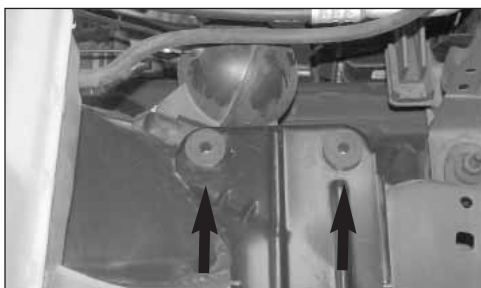

21. Install the two provided threaded inserts into the lower airbox mounting plate as shown.



22. Install the heat shield assembly into the vehicle so the bracket lines up with the factory in the core support and the heat shield holes line up with the threaded inserts installed in step #21.

NOTE: On vehicles that have a wiring harness secured to the core support, it will be necessary to remove the factory bolt, install the bracket under the wiring harness and reattach with the bolt provided.



23. Install the provided crankcase vent hose onto the fitting at the valve cover then attach the other end to the port on the K&N® intake tube.



24. Reconnect the mass air sensor electrical connection.



25. Install the air filter and secure with hose clamp provided.



26. Reinstall the engine cover and secure with the factory mounting bolts.



27. Reconnect the vehicle's negative battery cable. Double check to make sure everything is tight and properly positioned before starting the vehicle.

28. It will be necessary for all K&N® high flow intake systems to be checked periodically for realignment, clearance and tightening of all connections. Failure to follow the above instructions or proper maintenance may void warranty.

ROAD TESTING:

1. Start the engine with the transmission in neutral or park, and the parking brake engaged. Listen for air leaks or odd noises. For air leaks secure hoses and connections. For odd noises, find cause and repair before proceeding. This kit will function identically to the factory system except for being louder and much more responsive.

2. Test drive the vehicle. Listen for odd noises or rattles and fix as necessary.

3. If road test is fine, you can now enjoy the added power and performance from your kit.

4. K&N Engineering, Inc., suggests checking the air filter element periodically for excessive dirt build-up. When the element becomes covered in dirt (or once a year), service it according to the instructions on the Recharger® service kit, part number 99-5050 or 99-5000.

STREET LEGAL IN MOST STATES

NOT LEGAL FOR USE IN CA & OTHER STATES ADOPTING CA EMISSIONS STANDARDS

See our catalog or knfilters.com for CARB status on each part for a specific vehicle

* FREE K&N® decal To register your warranty, please see us online at knfilters.com/register. FREE K&N® decal *