



AIRCHARGER™ HIGH-FLOW INTAKE KITS



INSTALLATION INSTRUCTIONS

63-1050

Chevrolet
2001-04 Corvette
V8-5.7L

NOTE:

Due to close tolerances, the intake tube may rub the underhood insulation.

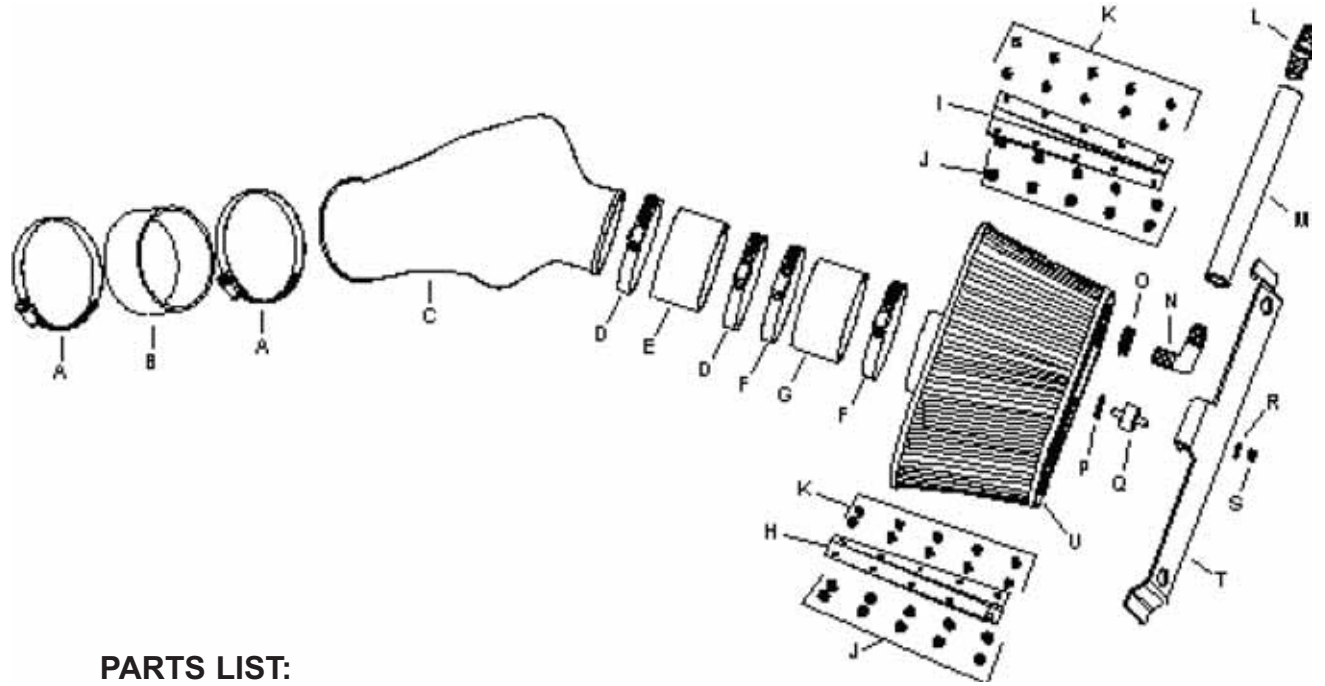

TOOLS NEEDED:

- Flat Blade Screwdriver
- 3/8" Wrench
- 7mm Wrench
- 10mm Wrench
- 1/8" Allen Wrench
- Ratchet
- Socket Extension
- 10mm Socket
- File

PARTS LIST:

Description	Qty.	P/N	Description	Qty.	P/N
A Hose Clamp, #64 midi	2	08650	L Hose mender; 1/2" to 5/8", barbed	1	08726
B Silicone hose 4.0 x 1.75	1	08755	M Silicone hose 5/8" id x 9"	1	08691
C Intake tube (CA)	1	087050	N Hose mender 5/8", 90 deg.	1	08072
D Hose Clamp #56	2	08620	O Grommet 1-1/8" od x 5/8" id x 5/16" thk.	1	08053
E Silicone hose 3.5 x 2.0	1	08630	P Washer, rubber, 1"x.300	1	21685
F Hose clamp #60	2	08624	Q Rubber stud	1	07027
G Silicone hose	1	08621	R Washer 1" od x 1/4" id	1	08160
H Bracket "Z" left	1	070842	S Nylock nut 6mm	1	07553
I Bracket "Z" right	1	070832	T Bracket	1	07137
J Nut; 10-32 ss nylock jam	20	08253	U Air filter	1	RP-5070
K Bolt; 10-32 x 3/8" ss btn head	20	08387			

NOTE: FAILURE TO FOLLOW INSTALLATION INSTRUCTIONS AND NOT USING THE PROVIDED HARDWARE MAY DAMAGE THE INTAKE TUBE, THROTTLE BODY AND ENGINE.

TO START:

1. Turn the ignition OFF and disconnect the vehicle's negative battery cable.



2. Disconnect the mass air sensor electrical connection.



3. Disconnect the air injection vent hose.



4. Release the push clips that retain the stock intake tube to the upper radiator cover.



5. Loosen the hose clamp on the intake hose at the throttle body.



6. Pull the airbox towards the engine to release it from its mounting grommets.



7. Detach the intake hose from the throttle body and remove the entire air intake assembly. **NOTE: K&N recommends that customers do not discard factory air intake.**



8. Detach the wiring harness retaining clip from the lower radiator cover.

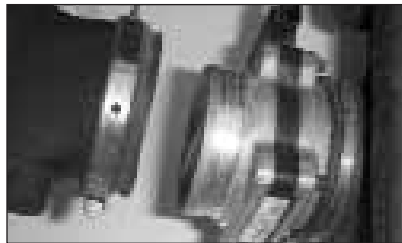

9. Loosen the hose clamp and detach the stock intake tube from the mass air sensor.



10. Remove the mass air sensor hose clamp.



11. Remove the mass air sensor from the airbox.

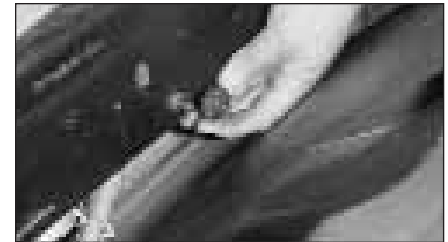

12. Remove the two grommets from the airbox mounting points.



13. Attach the 3.75" ID silicone hose (08621) onto the flange of the Air filter element.



14. Install the mass air sensor into the silicone hose with the arrow on the mass air sensor pointing away from the Air filter element.

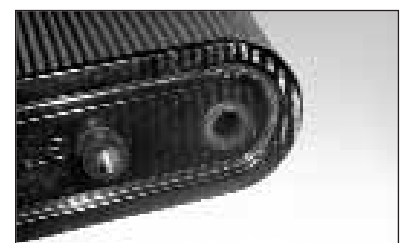

15. Install the 5/8" ID grommet and the rubber mounted stud into the top plate of the Air filter element.

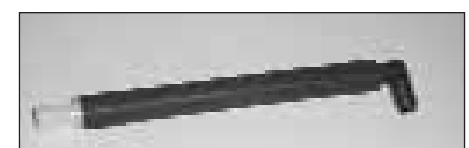

16. Assemble the 90 degree vent, hose mender and vent hose provided as shown.

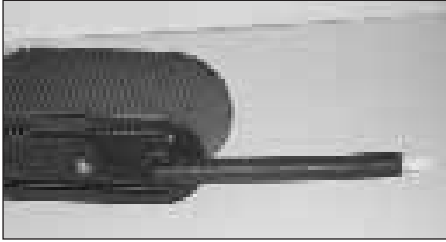

17. Insert the 90 degree vent into the grommet in the top plate of the filter.



18. Install the 4" ID silicone hose (08755) onto the K&N intake tube.

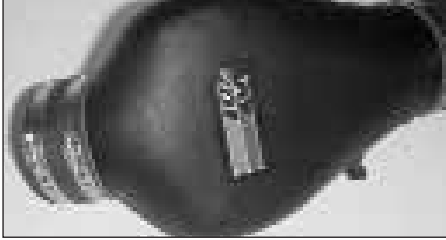

19. Install a 3.5" ID silicone hose (08630) onto the K&N intake tube.



20. Attach the angled bracket to the rubber mounted stud using the provided hardware.
Note: Do not tighten completely at this time.

21. Install the grommets removed in step 12 into the holes in the angled bracket.



22. Assemble the intake tube and Air filter element assemblies.



23. Install the K&N intake assembly.

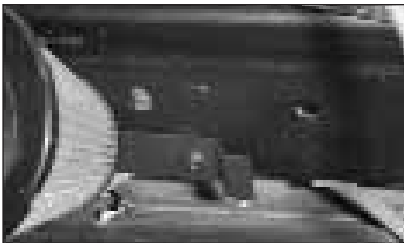

24. Install the angled bracket onto the original airbox mounting points.

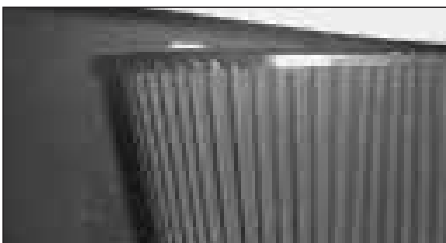

25. Using the top of the Air filter element as a guide, mark the lower radiator cover a minimum of 1/2" above the filter.

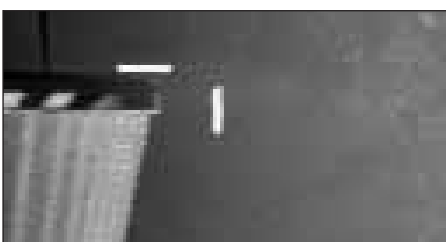

26. Using the Air filter element as a guide, mark a minimum of 1/2" away from the Air filter Element.

27. Release the angled bracket from its mounting points and remove the K&N intake assembly.



28. Loosen and remove the four bolts that retain the upper radiator cover.



29. Remove the upper radiator cover.

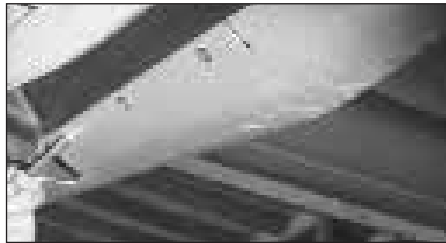

30. Loosen and remove the five bolts that mount the lower radiator cover to the bumper cover on the underside of the car.



31. Loosen and remove the two bolts that retain the lower radiator cover to its mounting brackets.



32. Detach the courtesy lamp wiring harness from the lower radiator cover and disconnect air temp. sensor at the right bottom corner of radiator cover.



33. Pull firmly to release the radiator cover from its retaining clips.



34. Remove the lower radiator cover.

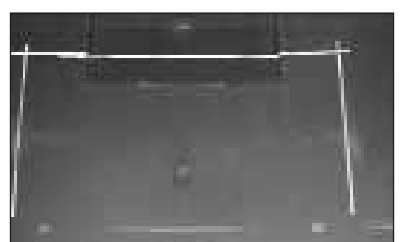

35. Using the indicated horizontal and vertical marks, connect the upper and side trim lines as shown.



36. Using a 5/16" drill bit, drill a hole where the horizontal and vertical lines intersect.



37. Using a jigsaw, cut along the horizontal and vertical lines.

Note: It will be necessary to clean up the cuts with a file.



38. Hold the right angled "Z" bracket in place, using a 3/16" drill bit, drill out the five outer holes.

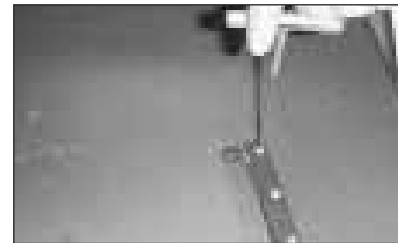

39. Secure the bracket to the lower radiator cover with the hardware provided.

40. Repeat the two previous steps with the left angled "Z" bracket.



41. Drill out the five inner holes of each bracket.

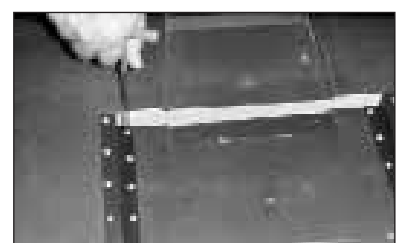

42. Secure the flap to the brackets with the hardware provided.



43. Reinstall the lower radiator cover.

44. Reattach the courtesy lamp wiring harness and the air temp sensor to the lower radiator cover.

45. Secure the lower radiator cover to the bumper cover and mounting brackets using the bolts removed in steps 39 and 40.

46. Reinstall the upper radiator cover and secure with the original retaining bolts. Do not tighten completely.



47. Reinstall the K&N intake assembly then adjust the radiator cover for best fit under the intake tube, then tighten the 4 retaining bolts.



48. Install the angled bracket onto the original airbox mounting points.



49. Attach the air injection hose to the hose mender.



50. Attach the silicone hose to the throttle body and tighten the hose clamps.



51. Reconnect the mass air sensor electrical connection.

52. Reattach the wiring harness retaining clip to the lower radiator cover.



53. Reconnect the vehicle's negative battery cable. Double check to make sure everything is tight and properly positioned before starting the vehicle.

54. It will be necessary for all Airchargers to be checked periodically for realignment, clearance and tightening of all connections. Failure to follow the above instructions or proper maintenance may void warranty.

ROAD TESTING:

1. Start the engine with the transmission in neutral or park, and the parking brake engaged. Listen for air leaks or odd noises. For air leaks secure hoses and connections. For odd noises, find cause and repair before proceeding. This kit will function identically to the factory system except for being louder and much more responsive.

2. Test drive the vehicle. Listen for odd noises or rattles and fix as necessary.

3. If road test is fine, you can now enjoy the added power and performance from your kit.

4. K&N Engineering, Inc., suggests checking the air filter element periodically for excessive dirt build-up. When the element becomes covered in dirt (or once a year), service it according to the instructions on the Recharger service kit, part number 99-5050 or 99-5000.

STREET LEGAL IN MOST STATES

**NOT LEGAL FOR USE IN CA & OTHER STATES
ADOPTING CA EMISSIONS STANDARDS**

See our catalog or knfilters.com for CARB status on each part for a specific vehicle