



INSTALLATION INSTRUCTIONS

57-9016-1

TOYOTA

Tacoma

2000-04 L4-2.4L, 2.7L

4Runner

2000 L4-2.7L

NOTE: This kit was not designed to fit vehicles with a body lift.

TOOLS NEEDED:

phillips screwdriver
 14mm wrench
 13mm wrench
 12mm wrench
 10mm wrench
 4mm allen wrench
 5mm allen wrench
 5/8" wrench
 5/16" wrench
 drill
 7/8" drill bit

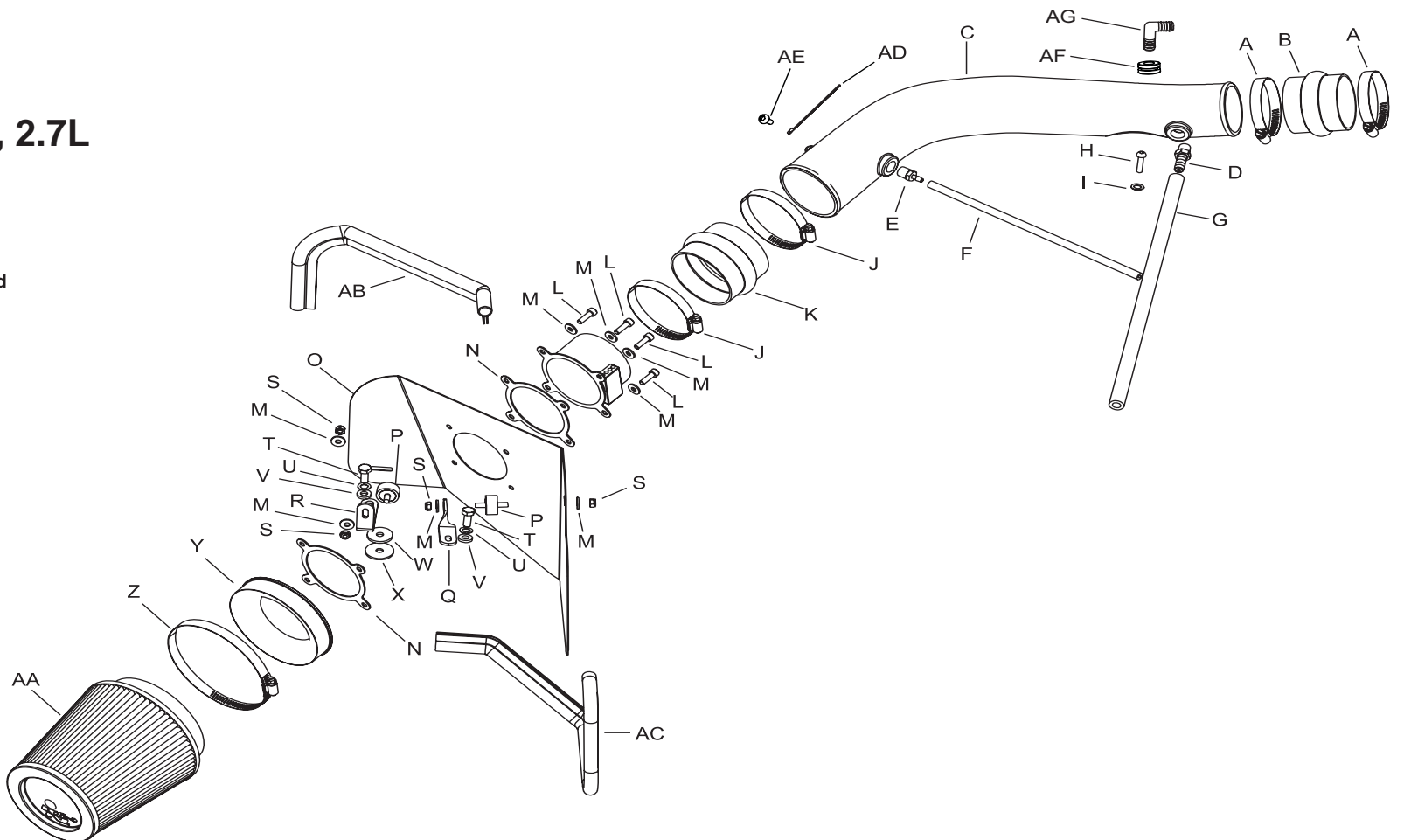

PARTS LIST:

Description	Qty.	Part #	Description	Qty.	Part #	Description	Qty.	Part #
A Hose Clamp #40	2	08554	M Washer 1/4	8	08275	Y Adapter	1	08781
B Hump Hose	1	08185	N Gasket	2	09040	Z Hose Clamp #80	1	08694
C Intake Tube	1	087011-1	O Heat Shield	1	07448	AA Air Filter	1	RF-1037
D Vent 3/8" Barb, 1/4 NPT	1	08047	P Rubber Mnt. Stud	2	07027	AB Edge Trim 20"L	1	102494
E Vent 3/16" Barb, 1/4 NPT	1	080021	Q Bracket, Twist	1	26606	AC Edge Trim 26"L	1	102488
F Silicone Hose	1	08147	R Bracket, L	1	26607	AD Cable Tie, 6"	1	21595
G Silicone Hose	1	08404	S Nut 6MM Nylock	4	07553	AE Screw; M4-7x12 ButtnHd. SS	1	07726
H Bolt Button Head	1	07729	T Bolt 8MM	2	07787	AF Grommet; 1-1/8"od, 5/8"id, 3/8"	1	080601
I Wave Washer 6MM	1	08174	U Wave Washer 8MM	2	08239	AG Vent; 90°, 5/8"Hose,	1	08072
J Hose Clamp #48	2	08601	V Flat Washer	2	08276			
K Hump Hose	1	08171	W Fender Washer	1	08130			
L Bolt 6MM-1.00x20MM Allen	4	07852	X Rubber Washer	1	21708			

NOTE: FAILURE TO FOLLOW INSTALLATION INSTRUCTIONS AND NOT USING THE PROVIDED HARDWARE MAY DAMAGE THE INTAKE TUBE, THROTTLE BODY AND ENGINE.

TO START:

1. Turn off the ignition and disconnect the negative battery cable.

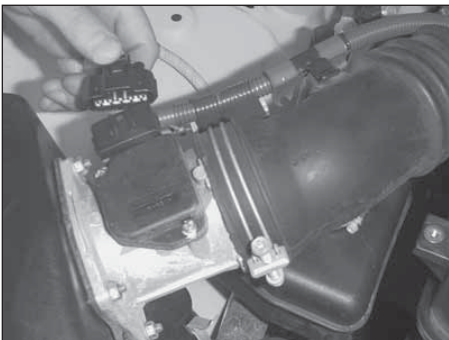

2. Disconnect the mass air sensor electrical connection.

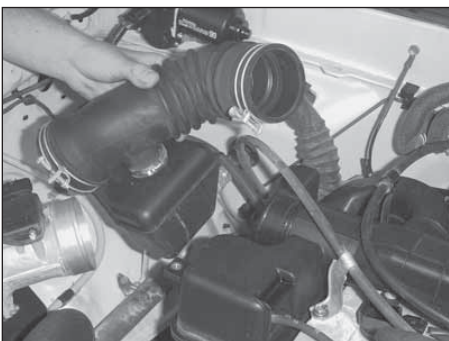

3. Loosen the two hose clamps on the intake hose and remove the intake hose as shown.



4. Loosen the three bolts that secure the air cleaner assembly, then remove the complete assembly as shown.



5) Loosen and remove the two nuts that secure the resonator.

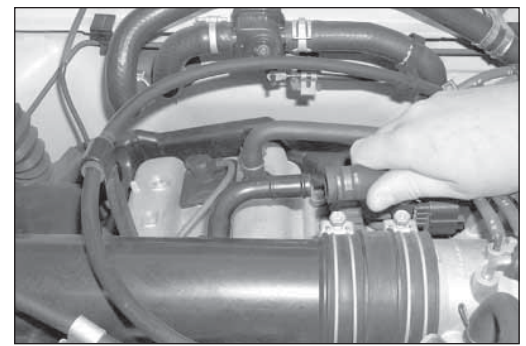

6. Vehicles equipped with an idle air vent line, disconnect vent line as shown.

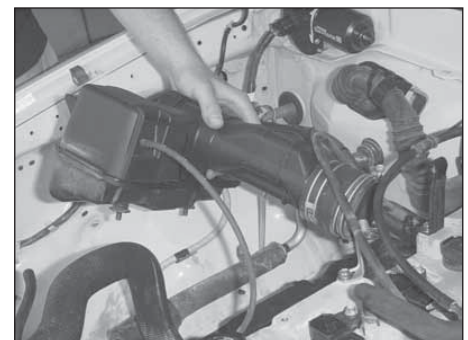

7. Loosen the hose clamp at the throttle body and remove the remaining section of the intake assembly.

NOTE: K&N Engineering, Inc., recommends that customers do not discard factory air intake.

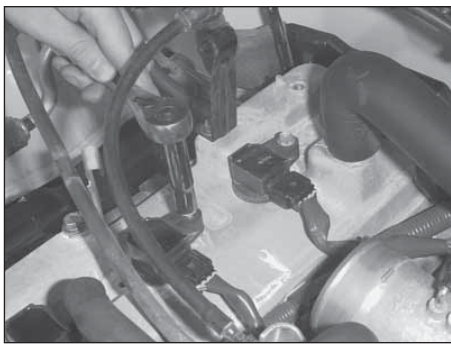

8. Loosen and remove the hex nut that secures the #2 coil pak to the cam cover.

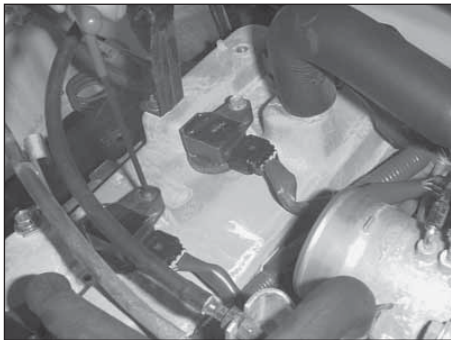

9. Replace the hex nut removed in step 8 with the provided button head screw and wave washer then secure the coil pack to the cam cover as shown.



10. Loosen and remove the four hex nuts that secure the mass air sensor to the air cleaner assembly then remove the mass air sensor as shown.

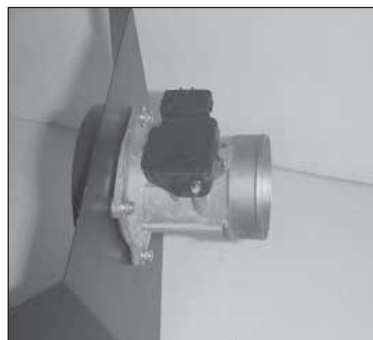

11. Assemble the mass air adapter, heat shield, gaskets and the mass air sensor using the hardware provided.



12. Assemble the rubber bumper stud onto the "L" bracket with the provided hardware as shown.
NOTE: Do not tighten completely.

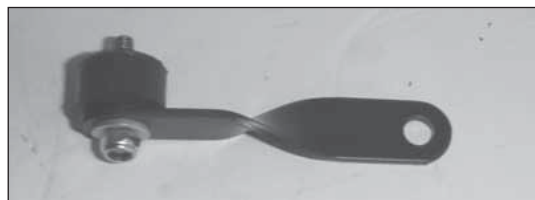

13. Assemble the rubber bumper stud onto the twist bracket with the provided hardware as shown.
NOTE: Do not tighten completely.



14. Install the twist bracket and the "L" bracket assembly onto the heat shield assembly with the provided hardware. Also install the trim seal onto the heat shield as shown.

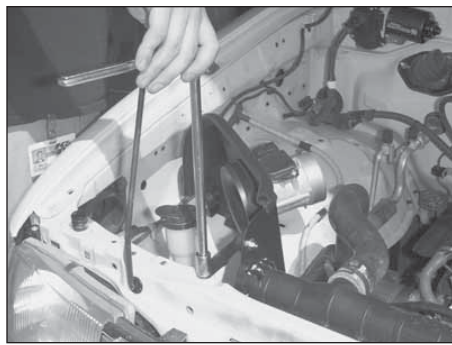

15. Install the heat shield assembly into the vehicle and secure it to the original air box mounting location as shown. Do not tighten completely.

NOTE: The fender washer and the rubber washer should be mounted between the fender and the "L" bracket.

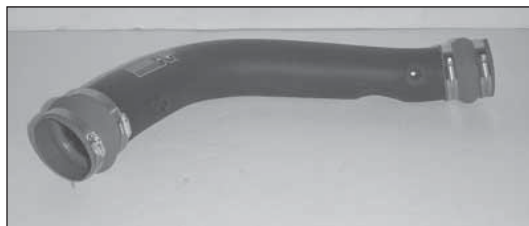

16. Secure the provided hump hoses onto the K&N® intake tube as shown using the provided hose clamp.

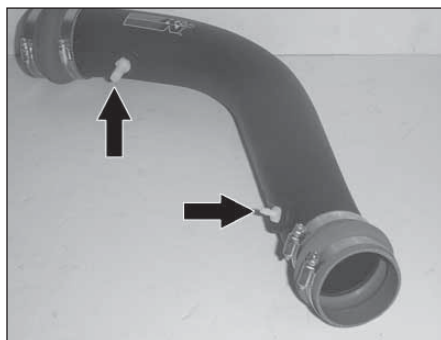

17. Install the two NPT fittings onto the K&N® intake tube as shown.

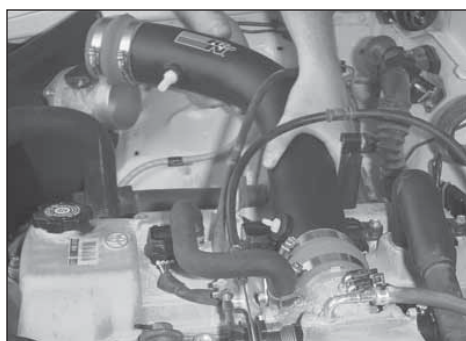

18. Install the intake tube onto the throttle body, then install onto the mass air sensor.

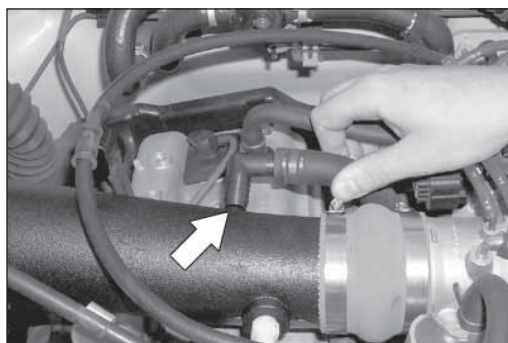

19. Vehicles equipped with an idle air vent line, install the 90 deg. fitting into vent line then mark the intake tube where the fitting lines up with tube. Vehicles that are not equipped with an idle air vent, continue on to step 23.



20. After marking the intake tube, remove from vehicle and drill a 7/8" hole into the intake tube then install the provided grommet as shown.

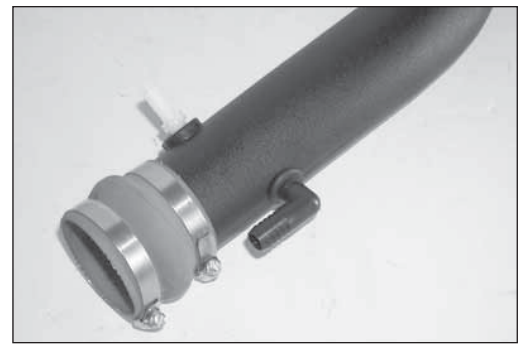

21. Install the 90 degree fitting into the intake tube as shown.

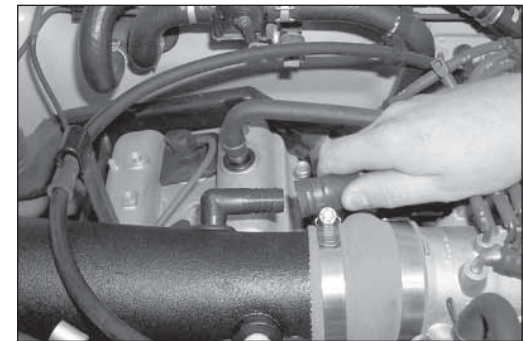

22. Vehicles equipped with the idle air vent line, reconnect vent line as shown.

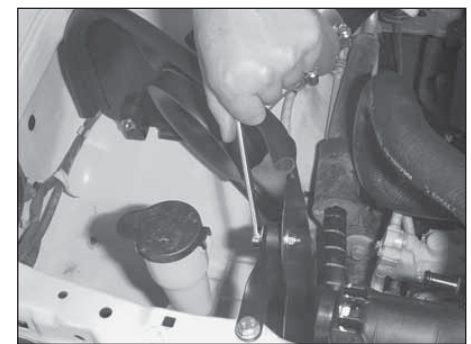

23. At this point, you can tighten the hardware located at the "L" and twist brackets as shown.

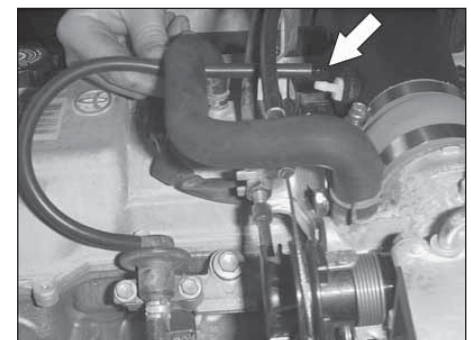

24. Install the provided silicone hose onto the fuel pressure regulator and connect the other end to the K&N® intake tube as shown.

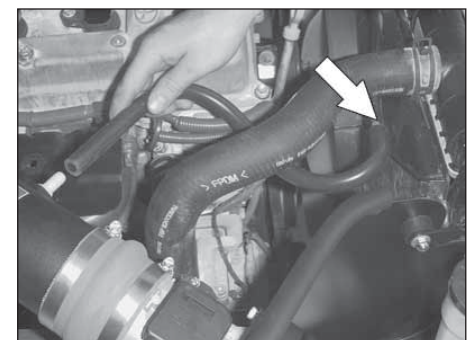

25. Install the provided silicone hose onto the EVAP canister vent and secure the other end onto the K&N® intake tube as shown.

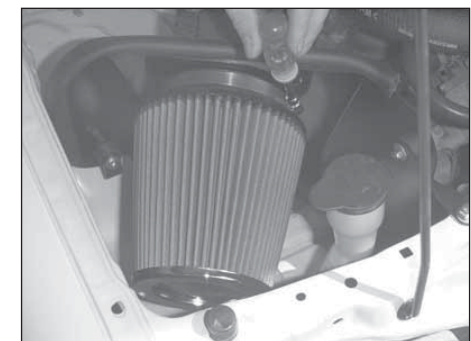

26. Install the K&N® air filter onto the mass air adapter and secure with the provided hose clamp as shown.

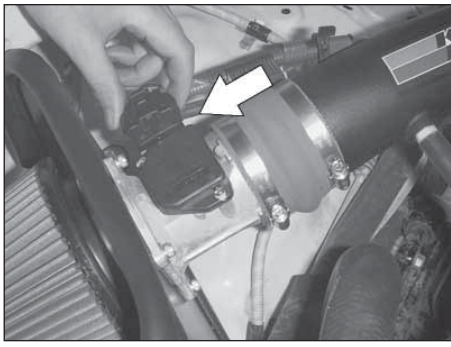

27. Reconnect the mass air sensor electrical connection.

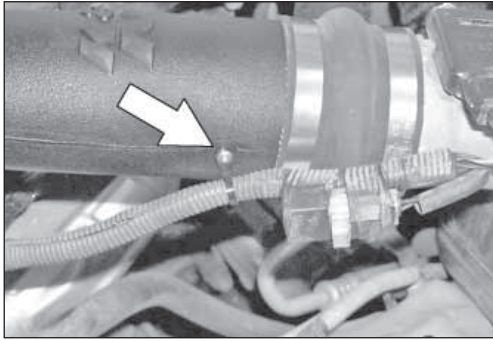

28. Secure the mass air sensor wiring harness to the intake tube with the tie wrap and screw provided.

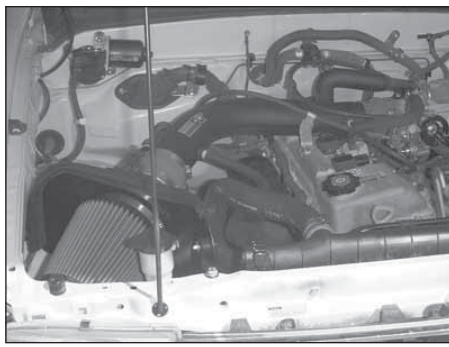

29. Reconnect the vehicle's negative battery cable. Double check to make sure everything is tight and properly positioned before starting the vehicle.

30. The C.A.R.B. exemption sticker, (attached), must be visible under the hood, so the emissions inspector can see it when the vehicle is required to be tested for emissions. California requires testing every two years, other states may vary.

31. It will be necessary for all K&N® high flow intake systems to be checked periodically for realignment, clearance and tightening of all connections. Failure to follow the above instructions or proper maintenance may void warranty.

ROAD TESTING:

1. Start the engine with the transmission in neutral or park, and the parking brake engaged. Listen for air leaks or odd noises. For air leaks secure hoses and connections. For odd noises, find cause and repair before proceeding. This kit will function identically to the factory system except for being louder and much more responsive.

2. Test drive the vehicle. Listen for odd noises or rattles and fix as necessary.

3. If road test is fine, you can now enjoy the added power and performance from your kit.

4. K&N Engineering, Inc., suggests checking the air filter element periodically for excessive dirt build-up. When the element becomes covered in dirt (or once a year), service it according to the instructions on the Recharger® service kit, part number 99-5050 or 99-5000.

50-STATE STREET LEGAL
K&N CARB EXEMPT K&N

* FREE K&N® decal To register your warranty, please see us online at knfilters.com/register. FREE K&N® decal *