



FILTERCHARGER[®] INJECTION PERFORMANCE KIT

-INSTALLATION MANUAL-

Toyota Supra Turbo

1987-1995

L6-3.0L Turbo

P/N 57-9004

CARB E.O.# D-269-3

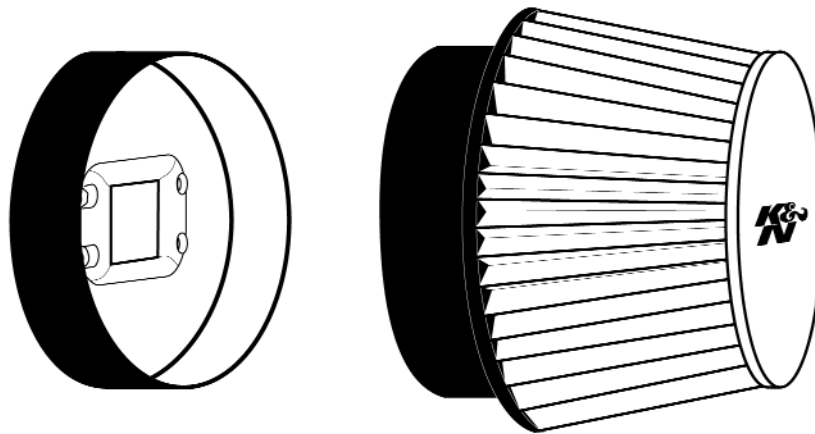

K&N Engineering, Inc.

1455 Citrus St.

P.O. Box 1329

Riverside, CA 92502

K&N Filtercharger® Injection Performance Kit #: **57-9004**

Application: **1987-95 Toyota Supra Turbo L6-3.0L engine**

Air-flow sensing device: **Karman Vortex air flow meter**

BASIC DESIGN CONCEPT

This K&N Filtercharger® Injection Performance Kit (hereafter referred to as: **FIPK**) is designed to be less restrictive than the OEM air filter system. Low restriction air filters allow the engine to have better throttle response as well as more power throughout the RPM band. K&N has designed this **FIPK** to exactly replace the OEM factory air cleaner case, with a precision engineered aluminum adapter and all the necessary mounting brackets, bolts, screws and nuts. Additionally, it is important to note, if the O.E.M. air cleaner case has emission control devices and/or hoses, that all these parts will be installed as necessary to the new assembly.

Each **FIPK** has a specially designed filter with woven cotton fabric sandwiched between 2 layers of wire mesh screen. The screen and fabric combination creates a grid-like effect which actually straightens out the incoming air as it passes through the filter. In addition to the filter, this kit has a uniquely designed adapter with a built-in velocity stack. This velocity stack is beneficial in further smoothing out the incoming air flow and allowing for a less restrictive entry into the engine. (Air moving in a straight direction moves faster than tumbling air thus creating an increase in air flow). See the figure below.

AIR CLEANER DESIGN EFFECTIVENESS

To design an effective performance air filter assembly, two factors must be considered: the air filtering element and the air filter adapter. On fuel injected, computer controlled vehicles, there can be a substantial gain in performance by using a less restrictive air filter assembly. Original equipment air filter assemblies tend to be more restrictive than the performance enthusiast would like, therefore, by changing to the less restrictive K&N **FIPK**, the air flow potential of the engine can be fully maximized without jeopardizing important emission standards. (see figures below)

EMISSIONS LEGAL

The **FIPK** is street legal for use on the emission controlled vehicles that it was originally designed to fit. These kits replace the original air filter case and do not eliminate the emission controls. The high temperature label contains the EO # assigned by C.A.R.B. that will allow a vehicle installed with the FIPK to pass the visual inspection at an authorized Smog Inspection station.

BEFORE F.I.P.K.

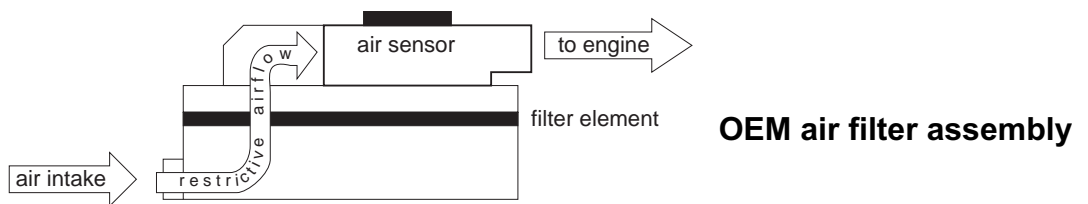

AFTER F.I.P.K.

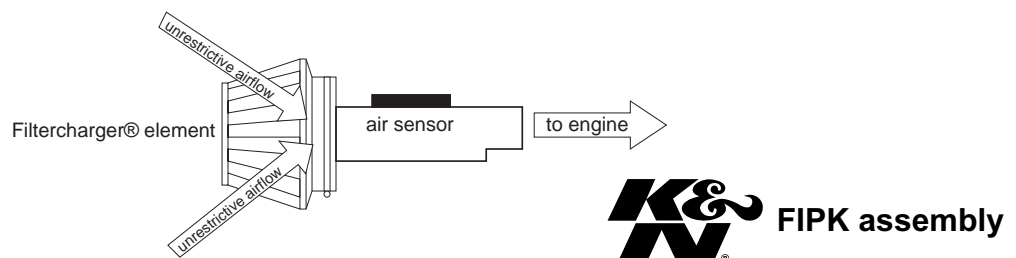

INSTALLATION INSTRUCTIONS

CAUTION!! PLEASE READ CAREFULLY AND COMPLETELY BEFORE BEGINNING WORK ON YOUR VEHICLE. K&N suggests that you have a repair manual available for reference during installation of the K&N Filtercharger® Injection Performance Kit.

TOYOTA SUPRA TURBO ENGINE COMPARTMENT

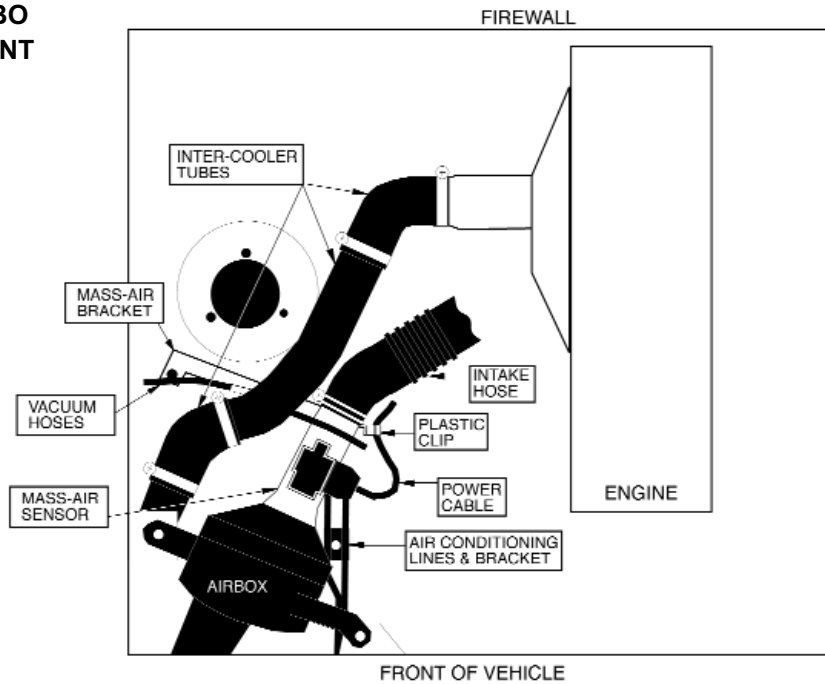

INSTALLATION

- 1) Disconnect the vehicle's negative battery cable.
- 2) Remove the inter-cooler tubes from the vehicle, held in place by hose clamps. (see fig. 1)
- 3) Remove the bolts holding the airbox to the body. There are 2 on the airbox and 1 on the mass-air bracket.
- 4) Loosen the hose clamp where the intake hose connects to the mass-air sensor.
- 5) Carefully unplug the power cable from the mass-air sensor (held in place by a small spring-clip) and remove the wire from the mass-air sensor (hooked to a small bracket with a plastic clip).
- 6) Un-hook the vacuum hoses from the mass-air bracket. Do not remove them from the vehicle.
- 7) Remove the mass-air sensor and airbox as an assembly.
- 8) Unclip the airbox lid and remove the air filter.
- 9) Remove the nuts holding the mass-air sensor to the airbox (there are metal locking tabs over the nuts that must be bent out of the way with a straight-bladed screwdriver).
- 10) Remove the foreign-object-deflector screen and separate the mass-air sensor from the airbox.
****CAUTION** The honeycomb material in the mass-air sensor is very fragile. Be careful not to damage it.**
- 11) Remove the 4 studs from the mass-air sensor. If you thread two nuts on to the stud, and tighten them together, you can then back the stud out with the bottom nut.

fig. 1

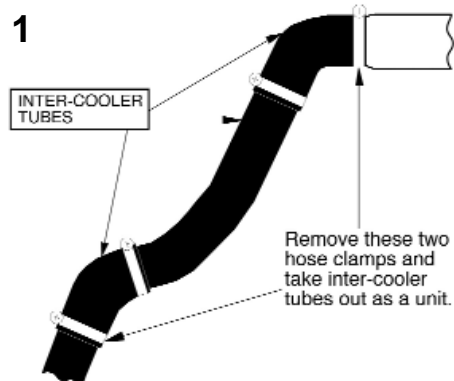
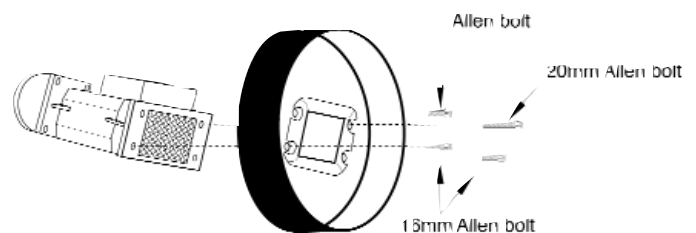

fig. 2



- 12) Install the K&N filter adapter onto the mass-air sensor using the stock gasket and four allen bolts. Use a thread locking compound and do not over-tighten the bolts. (see fig. 2)
- 13) Install the "L" bracket onto the 20mm bolt using the nylock nut provided, but do not completely tighten at this time. (see fig. 3)

fig. 3

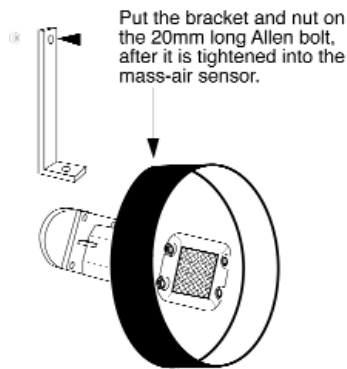
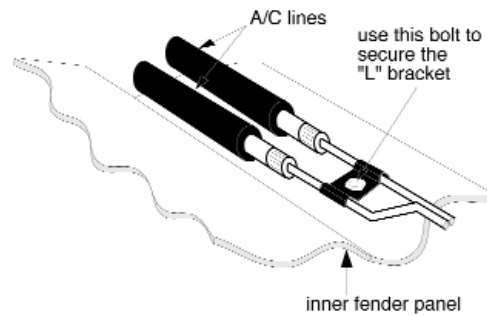

fig. 4



- 14) Remove the bolt holding the air conditioning lines to the fenderwell. If the vehicle is not equipped with A/C, the hole will be empty. (see fig. 4)
- 15) Install the mass-air / adapter assembly into the intake hose, but do not tighten the hose clamp at this time.
- 16) Use the original bolts to secure the mass-air bracket and the "L" bracket, to the fenderwell. If the vehicle is not equipped with A/C, use a supplied allen bolt to secure the "L" bracket.
- 17) Tighten the nut on the "L" bracket, at the adapter, and the hose clamp on the intake hose.
- 18) Re-connect the vacuum hoses to the mass-air bracket.
- 19) Plug the power cable in to the mass-air sensor and secure the wire to the sensor with the plastic clip.
- 20) Install the K&N Filtercharger® onto the adapter, do not over-tighten hose clamp!
- 21) Install the inter-cooler tubes back into the vehicle.
- 22) Re-connect the battery cable. Double check to make sure everything is tight and properly positioned before starting the vehicle.
- 23) The C.A.R.B. exemption sticker, (attached) must be placed in a visible area under the hood, so that an emissions inspector can see it when the vehicle is required to be tested for emissions. California requires testing every two years, other states may vary.
- 24) It will be necessary for all FIPK's to be checked periodically for realignment, clearance and tightening of all connections. Failure to follow the above instructions or proper maintenance may void warranty.

FREE K&N DECAL To register your warranty, please see us online at knfilters.com/register. FREE K&N DECAL

ROAD TESTING

Start the engine with the transmission in neutral or park, and the emergency brake on. Listen for any air leaks or odd noises. If there are air leaks, make sure the hose connections are secure. If there are any odd noises, check for the cause and repair before proceeding. The K&N Filtercharger® Injection Performance Kit will function identically to the factory air filter with the exception of being slightly louder than stock and much more responsive. If all preliminary checks are okay, then a road test is necessary. Listen carefully for rattling or other odd noises and fix as necessary. If the road test is fine, you can enjoy driving as normal with the added response and power. We suggest that the Filtercharger® element be checked periodically for dirt. This is now very easy due to the open element configuration. If the filter material is overly dirty, service it according to the instructions that are in the Recharger service kit, part number 99-5050 or 99-5000. If you have any questions or problems, inquire at your nearest K&N dealer, or direct to K&N Engineering at (800) 858-3333.

PARTS LIST

desc	qty	part#
A 6mm -1.00 x 16mm allen bolt	4	07818
B 6mm -1.00 x 20mm allen bolt	1	07852
C 6mm -1.00 nylock nut	1	07553
D "L" bracket	1	07868
E die-cast filter adapter	1	08842
F size 104 hose clamp	1	08697
G Filtercharger® element	1	RC-2960

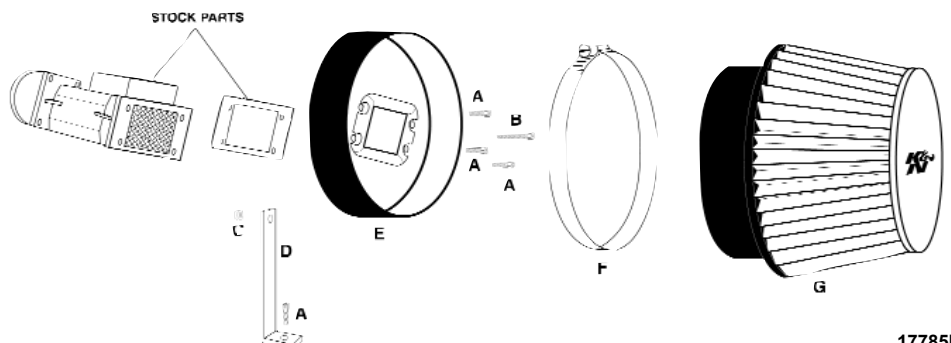

17785b
11/8/10