



# **FILTERCHARGER® INJECTION PERFORMANCE KIT**

— INSTALLATION MANUAL —

**Nissan 300ZX**

**1984-1989**

**V6-3.0 Turbo & non Turbo**

**P/N 57-6002**

**CARB E.O. # D-269-8**

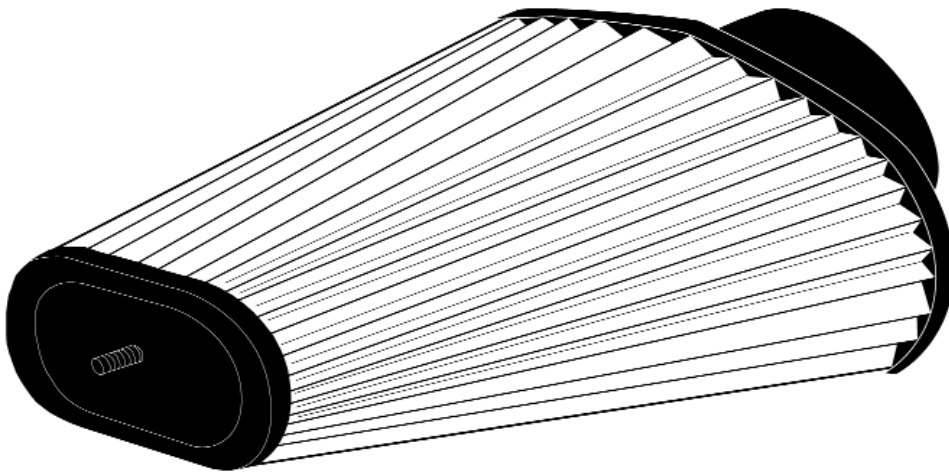

**K&N Engineering, Inc.**

**1455 Citrus Avenue**

**P.O. Box 1329**

**Riverside, CA 92502**

## K&N Filtercharger® Injection Performance Kit #: 57-6002

Application: **1984-89 Nissan 300ZX V6-3.0 turbo & non turbo**

Air-flow sensing device: **Nippondenso flap-door air flow meter**

### BASIC DESIGN CONCEPT

This K&N Filtercharger® Injection Performance Kit (hereafter referred to as: **FIPK**) is designed to be less restrictive than the OEM air filter system. Low restriction air filters allow the engine to have better throttle response as well as more power throughout the RPM band. K&N has designed this **FIPK** to exactly replace the OEM factory air cleaner case, with a precision engineered aluminum adapter and all the necessary mounting brackets, bolts, screws and nuts. Additionally, it is important to note, if the O.E.M. air cleaner case has emission control devices and/or hoses, that all these parts will be installed as necessary to the new assembly.

Each **FIPK** has a specially designed filter with woven cotton fabric sandwiched between 2 layers of wire mesh screen. The screen and fabric combination creates a grid-like effect which actually straightens out the incoming air as it passes through the filter. In addition to the filter, this kit has a uniquely designed adapter with a built-in velocity stack. This velocity stack is beneficial in further smoothing out the incoming air flow and allowing for a less restrictive entry into the engine. (Air moving in a straight direction moves faster than tumbling air thus creating an increase in air flow). See the figure below.

### AIR CLEANER DESIGN EFFECTIVENESS

To design an effective performance air filter assembly, two factors must be considered: the air filtering element and the air filter adapter. On fuel injected, computer controlled vehicles, there can be a substantial gain in performance by using a less restrictive air filter assembly. Original equipment air filter assemblies tend to be more restrictive than the performance enthusiast would like, therefore, by changing to the less restrictive K&N **FIPK**, the air flow potential of the engine can be fully maximized without jeopardizing important emission standards. (see figures below)

### EMISSIONS LEGAL

The **FIPK** is street legal for use on the emission controlled vehicles that it was originally designed to fit. These kits replace the original air filter case and do not eliminate the emission controls. The high temperature label, (attached) contains the EO # assigned by C.A.R.B. that will allow a vehicle installed with the FIPK to pass the visual inspection at an authorized Smog Inspection station.

### BEFORE F.I.P.K.

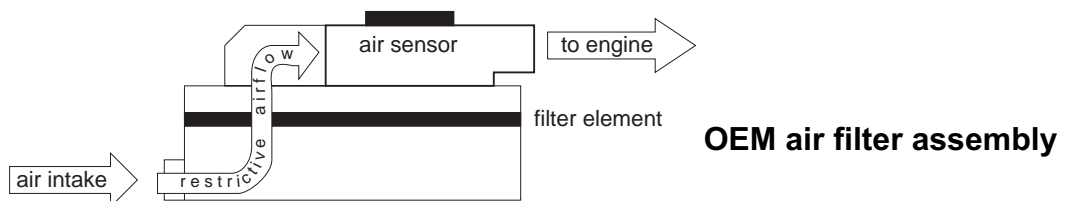

### AFTER F.I.P.K.

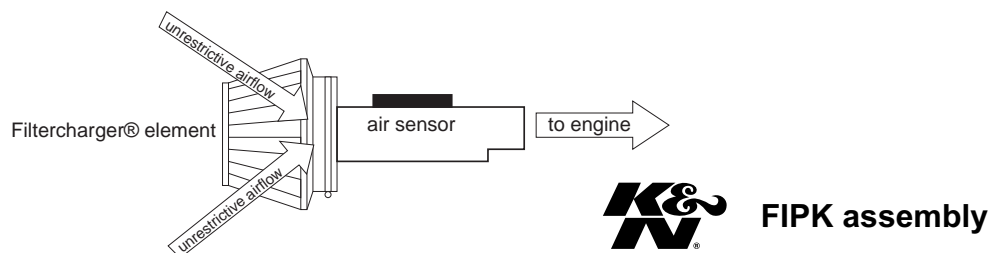

# INSTALLATION INSTRUCTIONS

CAUTION!! PLEASE READ CAREFULLY AND COMPLETELY BEFORE BEGINNING WORK ON YOUR VEHICLE.  
K&N suggests that you have a repair manual available for reference during installation of the K&N Filtercharger® injection performance Kit.

## NISSAN 300ZX ENGINE COMPARTMENT

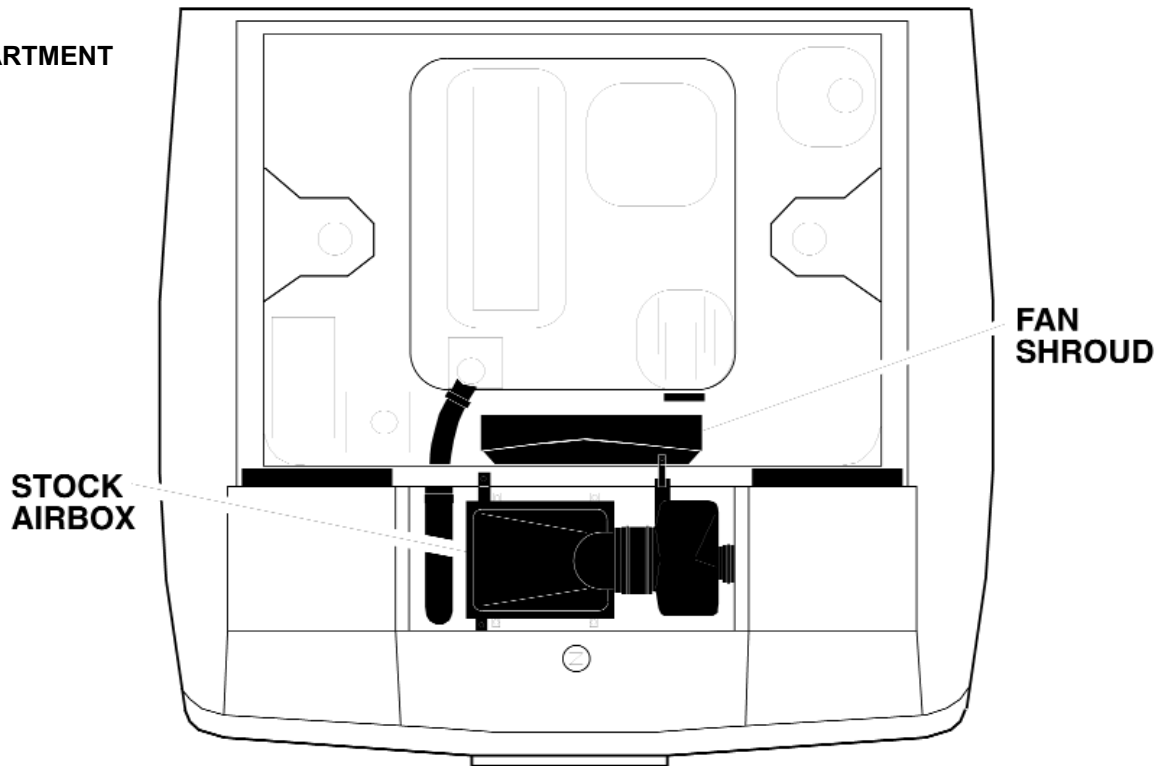

## INSTALLATION

- 1) Disconnect the vehicle's negative battery cable.
- 2) Remove the stock airbox. Loosen the intake hose clamp at the resonator chamber as shown in fig. 1, then remove the four bolts securing airbox to vehicle (note: one of the airbox bolts connects the fan shroud bracket, you will need to refasten that bracket with the stock bolt). Carefully remove the airbox and resonator chamber as a complete assembly from vehicle.
- 3) Remove the hose clamp on the airbox side of the resonator chamber and separate it from the airbox. (see fig. 2)

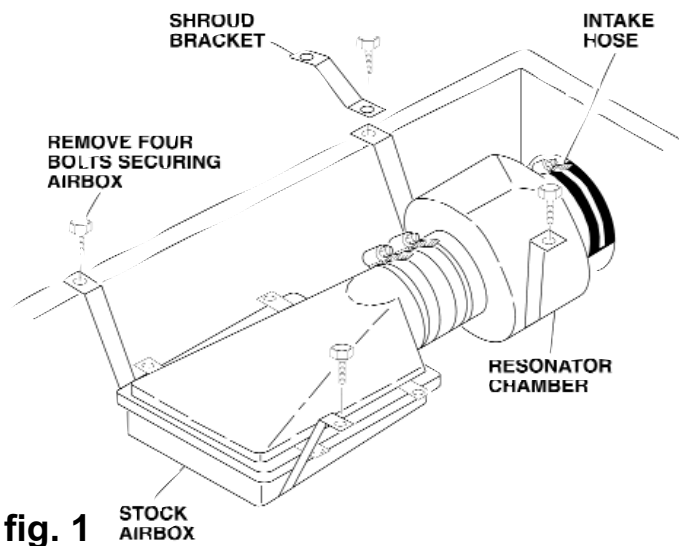

fig. 1

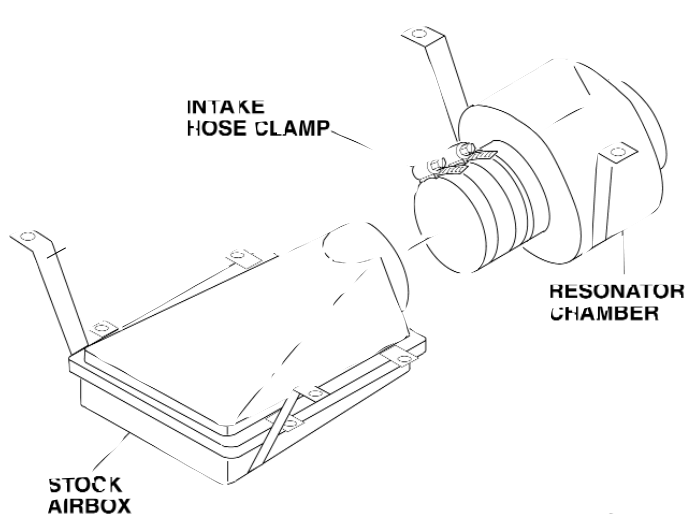

fig. 2

- 4) Reinstall the resonator chamber to the intake hose. (see fig 3.)
- 5) Install Filtercharger® to the resonator chamber. (do not completely tighten at this time)
- 6) fasten twist bracket to the filter and the unused hole in grill area. (see fig. 4)

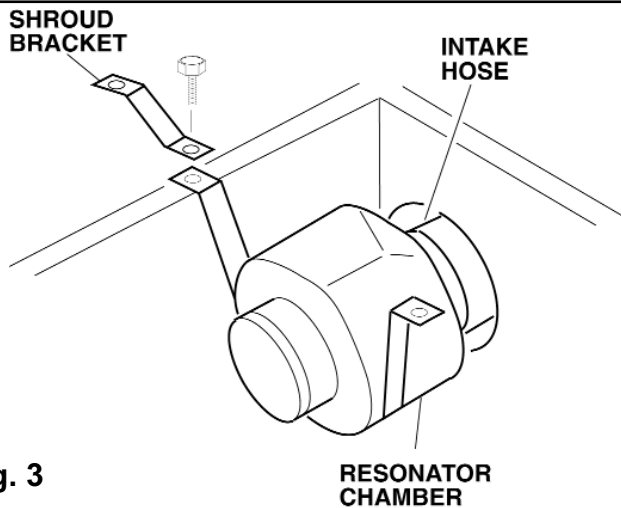

fig. 3

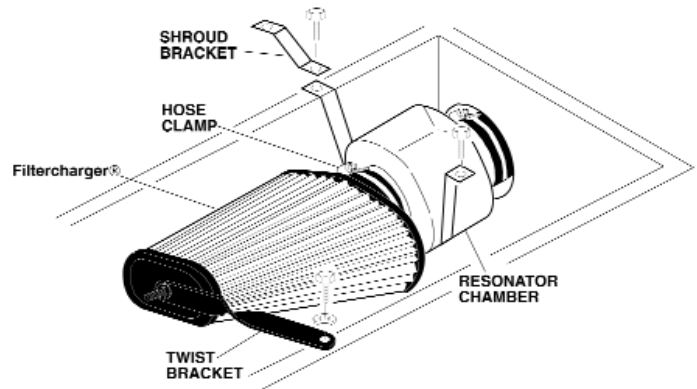

fig. 4

- 7) Position the filter for best clearance and tighten all remaining hardware.
- 8) Re-connect battery cable. Double check to make sure everything is tight and properly positioned before starting vehicle.
- 9) The C.A.R.B. exemption sticker, (attached) must be placed in a visible area under the hood, so that an emissions inspector can see it when the vehicle is required to be tested for emissions. California requires testing every two years, other states may vary.

### ROAD TESTING

Start the engine with the transmission in neutral or park, and the emergency brake on. Listen for any air leaks or odd noises. If there are air leaks, make sure the hose connections are secure. If there are any odd noises, check for the cause and repair before proceeding. The K&N Filtercharger® Injection Performance Kit will function identically to the factory air filter with the exception of being slightly louder than stock and much more responsive. If all preliminary checks are okay, then a road test is necessary. Listen carefully for rattling or other odd noises and fix as necessary. If the road test is fine, you can enjoy driving as normal with the added response and power. We suggest that the Filtercharger® element be checked periodically for dirt. This is now very easy due to the open element configuration. If the filter material is overly dirty, service it according to the instructions that are in the Recharger service kit, part number 99-5050 or 99-5000. If you have any questions or problems, inquire at your nearest K&N dealer, or direct to K&N Engineering at (909) 684-9762.

**\*FREE K&N DECAL To register your warranty, please see us online at [knfilters.com/register](http://knfilters.com/register). FREE K&N DECAL\***

### PARTS LIST

desc	qty	part#
A bolt; 6mm-1.00 x 12mm hex	1	07863
B nut; 1/4-20, nylock	1	07517
C washer; 6mm wave	1	08174
D bracket; twist	1	07068
E hose clamp #60	1	08624
F Filtercharger® element	1	RF-1011

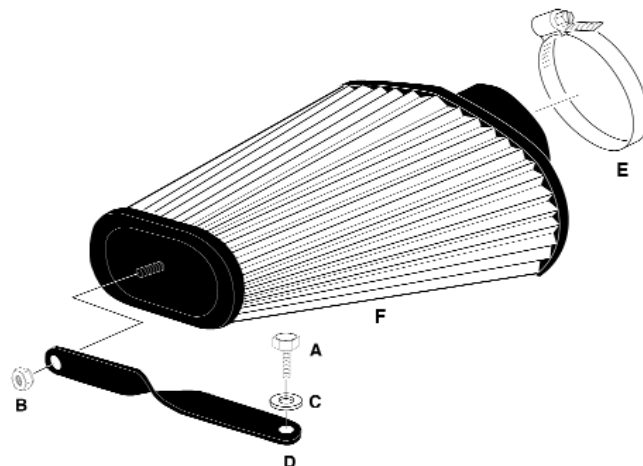

17791b  
6/2/04