

INSTALLATION INSTRUCTIONS

57-3029

**Chevrolet/GMC
S10/S15
1994-95 V6-4.3L TBI**

NOTE: This kit was not designed to fit vehicles with a body lift

TOOLS NEEDED:

7mm Wrench
8mm Wrench
7/16" Wrench

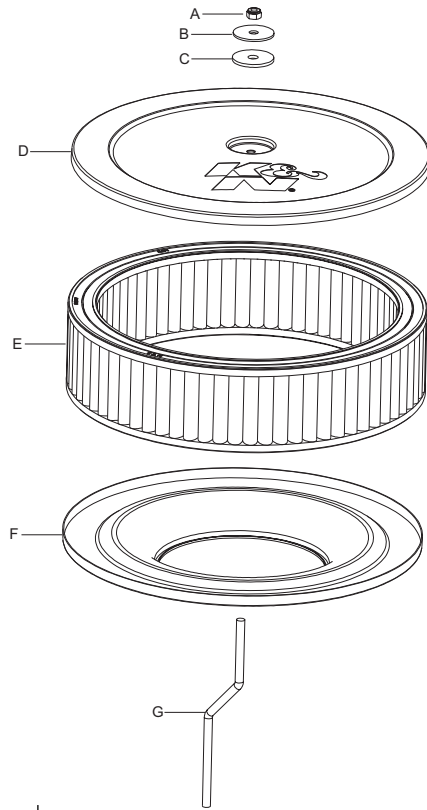

PARTS LIST:

Description	Qty.	P/N
A Nut, 1/4 nylock	1	07517
B Washer fender	1	08160
C Washer rubber	1	21685
D Top plate with K&N logo	1	06790
E Filtercharger	1	E-1230E
F Bottom plate, 5-1/8" Flg.	1	01988
G Z-stud	1	08019

TO START:

1. Turn the ignition OFF and disconnect the vehicle's negative battery cable.



2. Loosen and remove the hex bolt that secures the air inlet to the radiator support.



3. Loosen and remove the two wing nuts that secure the air cleaner assembly.

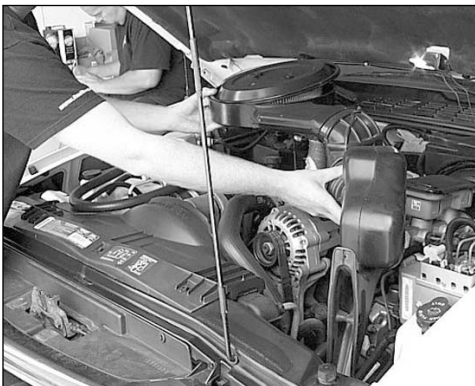

4. Remove the complete air cleaner assembly as shown.



5. Loosen and remove the two factory air cleaner studs as shown.

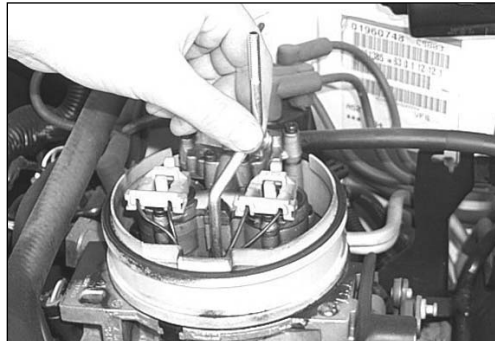

6. Install the provided Z stud into the threaded hole located just in front of and between the two throttle ports, then screw down completely.

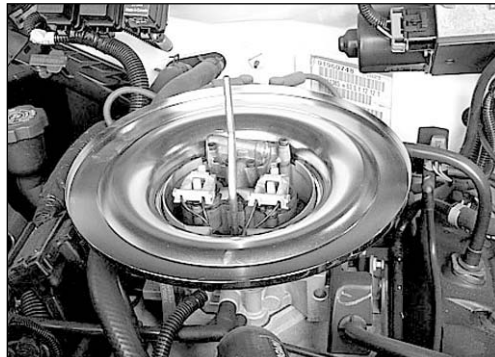

7. Install the K&N base plate on top of the factory plastic spacer as shown.

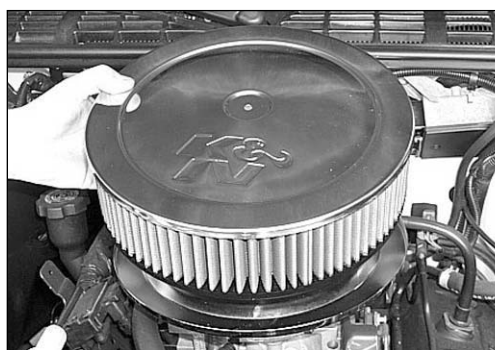

8. Install the K&N Filtercharger and the top plate onto the K&N base plate as shown.



9. Install the provided washers and secure the Filtercharger assembly with the provided nylock nut.

10. Reconnect the vehicle's negative battery cable. Double check to make sure everything is tight and properly positioned before starting the vehicle.

11. The C.A.R.B. exemption sticker, (attached), must be visible under the hood, so that an emissions inspector can see it when the vehicle is required to be tested for emissions. California requires testing every two years, other states may vary.

12. It will be necessary for all FIPK's to be checked periodically for realignment, clearance and tightening of all connections. Failure to follow the above instructions or proper maintenance may void warranty.

ROAD TESTING:

1. Start the engine with the transmission in neutral or park, and the parking brake engaged. Listen for air leaks or odd noises. For air leaks secure hoses and connections. For odd noises, find cause and repair before proceeding. This kit will function identically to the factory system except for being louder and much more responsive.

2. Test drive the vehicle. Listen for odd noises or rattles and fix as necessary.

3. If road test is fine, you can now enjoy the added power and performance from your kit.

4. K&N suggests checking the Filtercharger element periodically for excessive dirt build-up. When the element becomes covered in dirt (or once a year), service it according to the instructions on the Recharger service kit, part number 99-5050 or 99-5000.

FREE K&N DECAL To register your warranty, please see us online at knfilters.com/register. FREE K&N DECAL