



FUEL INJECTION PERFORMANCE KIT

FIPK

GENERATION II™

INSTALLATION INSTRUCTIONS

57-2567

FORD

2005-06 F-250

V10-6.8L

NOTE: This kit was not designed to fit vehicles with a body lift.

TOOLS NEEDED:

13mm Socket
10mm Socket
5/16" Socket
Ratchet
Extension
Flat Blade Screwdriver
4mm Allen Wrench
13mm Wrench
10mm Wrench

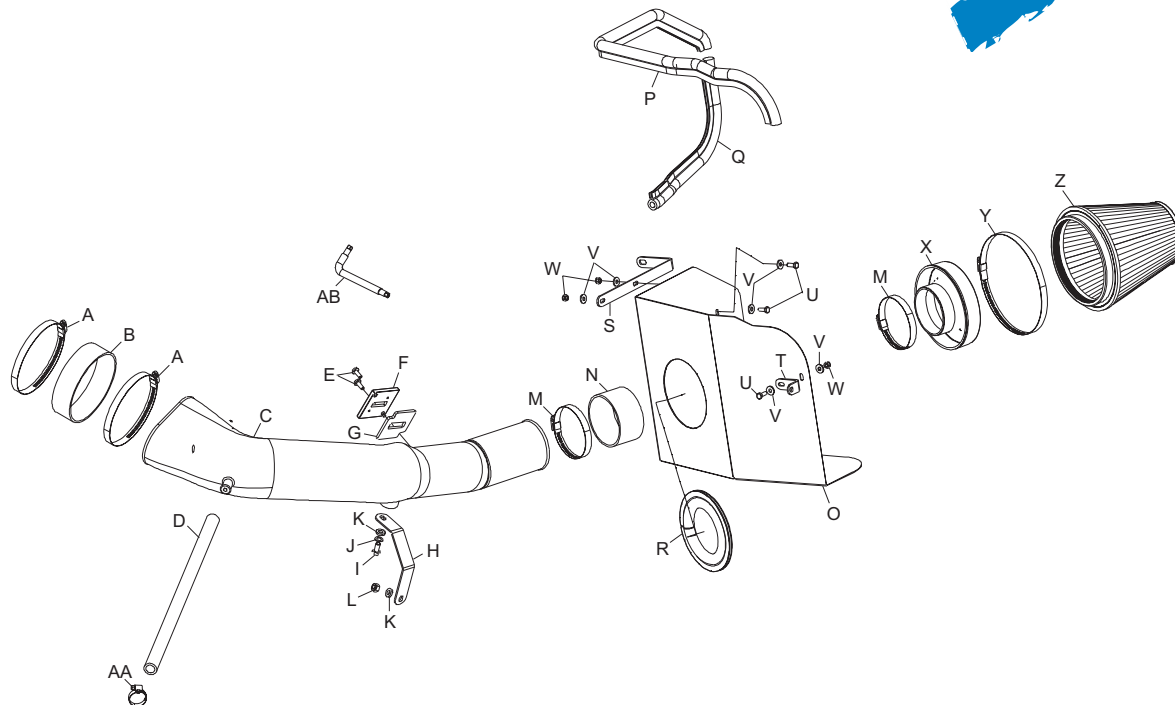

PARTS LIST:

Desc.	Qty.	Part #	Desc.	Qty.	Part #	Desc.	Qty.	Part #
A hose clamp #80	2	08694	H bracket "C"	1	26624	O heat shield	1	07668
B hose; 5.19" id x 1.5" l silicone	1	08627	I bolt; 8mm-1.25 x 16mm	1	07844	P edge trim 32"	1	102493
C intake tube (FO)	1	087187	J washer; 8mm wave	1	08239	Q edge trim 17"	1	102469
D hose; 5/8" id x 20" l, silicone	1	08542	K washer; 5/16" id flat	2	08276	R edge trim 14"	1	102475
E bolt; 6mm-1.00 x 16mm, b/h/a	2	07730	L nut; 8mm nylock	1	07542	S bracket; large "L"	1	010060
F adapter #420	1	21515	M hose clamp #52	2	08610	T bracket; small "L"	1	070812
G gasket	1	09069	N hose; 3.5" id x 2" l, silicone	1	08630	U bolt; 6mm-1.00 x 16mm	3	07703
						V washer; 1/4" id flat	6	08275
						W nut; 6mm nylock	3	07553
						X filter adapter #380	1	21512
						Y hose clamp #104	1	08697
						Z air filter	1	RC-5046
						AA hose clamp #8	1	08410
						AB wrench; T20 torx	1	69801

NOTE: FAILURE TO FOLLOW INSTALLATION INSTRUCTIONS AND NOT USING THE PROVIDED HARDWARE MAY DAMAGE THE INTAKE TUBE, THROTTLE BODY AND ENGINE.

TO START:

1. Turn the ignition OFF and disconnect the vehicle's negative battery cable.



2. Release the red locking tab on the mass air sensor electrical connector and then disconnect the mass air sensor electrical connection and unhook the wiring harness retainer from the intake tube.



3. Rotate the green locking tab on the crank case vent connector at the valve cover counter clockwise and then pull up and disconnect the crank case vent as shown.



4. Loosen the hose clamps, which secure the intake tube to the throttle body and to the air box, then remove the intake tube from the vehicle.



5. Remove the intake air bypass hose from the inner fender as shown.



6. Pull up on the rear of the air box assembly to dislodge it from the mounting grommets and then remove the air box from the vehicle.

NOTE: K&N recommends that customers do not discard factory air intake.

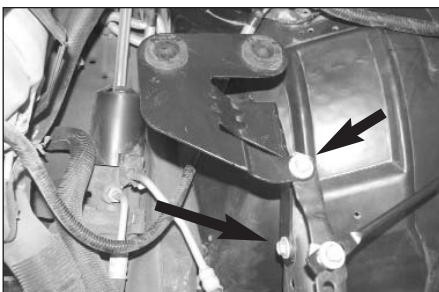

7. Remove the two bolts, which secure the air box mounting bracket shown, and then remove the airbox mounting bracket.

NOTE: Do not discard the bolts as they will be reused.

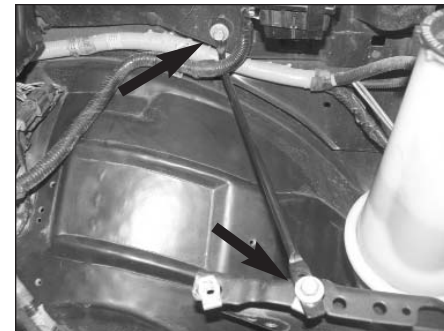

8. Remove the two bolts, which secure the support rod to the inner fender and to the core support, then remove the support rod from the vehicle.

NOTE: Do not discard the support rods and bolts, as they will be reused.

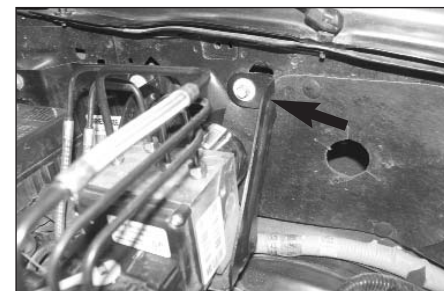

9. Remove the top front ABS brake pump mounting bracket bolt shown.

NOTE: Do not discard the bolts, as they will be reused.



10. Remove the upper air box mounting bracket bolt shown.

NOTE: Do not discard the bolts, as they will be reused.



11. Remove the two mass air sensor mounting screws with the T20 TORX wrench provided and then remove the sensor from the air box as shown.

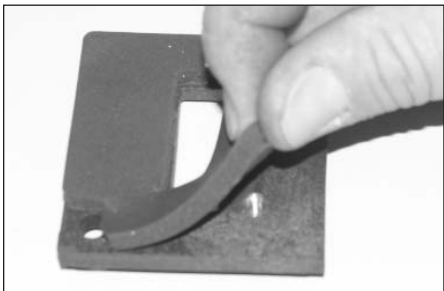

12. Peel the backing paper from the mass air sensor adapter plate gasket and install the gasket onto the mass air sensor adapter plate sticky side down.

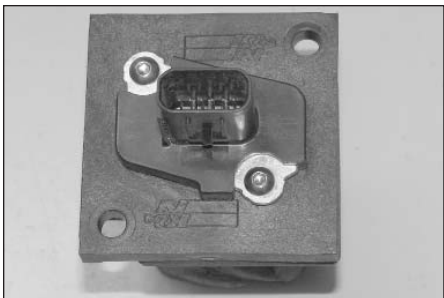

13. Install the mass air sensor into the mass air adapter plate and secure with the factory mounting screws as shown.

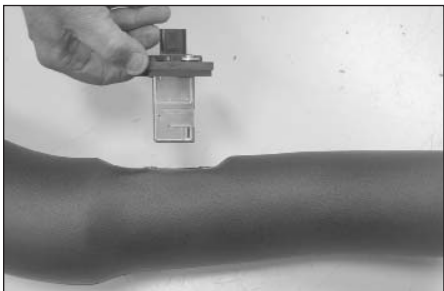

14. Install the mass air sensor assembly into the K&N intake tube as shown with the opening pointed towards the filter end of the tube.

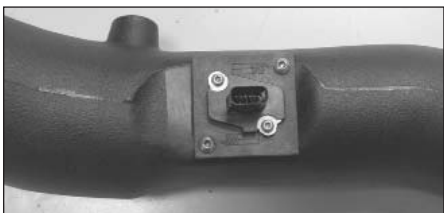

15. Secure the mass air sensor assembly into the K&N intake tube with the provided hardware.

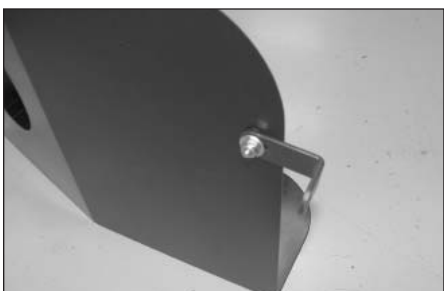

16. Install the small "L" bracket (070812) onto the heat shield as shown using the provided hardware.



17. Install the large "L" bracket (010060) onto the heat shield as shown using the provided hardware.



18. Install the edge trim into the heat shield opening as shown.



19. Install the edge trim to the heat shield as shown.



20. Install the heat shield assembly into engine compartment as shown.

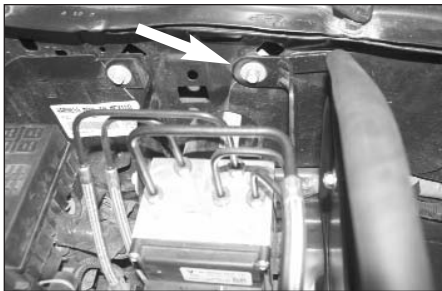

21. Place the rear heat shield bracket between the inner fender and the ABS pump mounting bracket and secure with the factory mounting bolt removed in step #9.



22. Secure the heat shield to the core support with the factory mounting bolts removed in step #10 as shown.

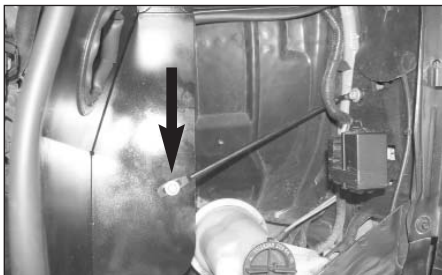

23. Reinstall the support rod with the factory mounting bolts removed in step #8 as shown.



24. Install the silicone hose (08627) onto the throttle body and secure with the provided hose clamp.



25. Install the tube mounting bracket (26624) onto the K&N intake tube and secure with the provided hardware as shown.

NOTE: The short end of the bracket attaches to the K&N intake tube.



26. Install the K&N intake tube onto the throttle body and align the mounting bracket so that it sits on the 8mm stud protruding from the cylinder head.



27. Secure the tube mounting bracket to the 8mm stud with the nut and washer provided. Align the K&N intake tube for best fit and then tighten the hose clamp and bracket mounting hardware.

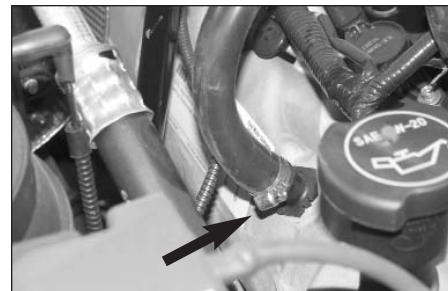

28. Install the provided crank case vent hose onto the valve cover port and secure with the provided hose clamp.



29. Install the crank case vent hose onto the K&N intake tube as shown.



30. Install the filter adapter into the Air filter and secure with the provided hose clamp.



31. Install the 3/4" silicone hose (08630) onto the filter adapter and secure with the provided hose clamp.

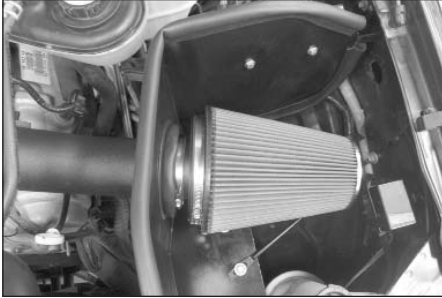

32. Install the air filter assembly onto the K&N intake tube and secure with the provided hose clamp.



33. Reconnect the mass air sensor electrical connection.



34. Reconnect the vehicle's negative battery cable. Double check to make sure everything is tight and properly positioned before starting the vehicle.

35. The C.A.R.B. exemption sticker, (attached), must be visible under the hood so that an emissions inspector can see it when the vehicle is required to be tested for emissions. California requires testing every two years, other states may vary.

36. It will be necessary for all FIPK's to be checked periodically for realignment, clearance and tightening of all connections. Failure to follow the above instructions or proper maintenance may void warranty.

ROAD TESTING:

1. Start the engine with the transmission in neutral or park, and the parking brake engaged. Listen for air leaks or odd noises. For air leaks secure hoses and connections. For odd noises, find cause and repair before proceeding. This kit will function identically to the factory system except for being louder and much more responsive.

2. Test drive the vehicle. Listen for odd noises or rattles and fix as necessary.

3. If road test is fine, you can now enjoy the added power and performance from your kit.

4. K&N suggests checking the Air filter element periodically for excessive dirt build-up. When the element becomes covered in dirt (or once a year), service it according to the instructions on the Recharger service kit, part number 99-5050 or 99-5000.

FREE K&N DECAL To register your warranty, please see us online at knfilters.com/register. FREE K&N DECAL