



# INSTALLATION INSTRUCTIONS

**57-1544**  
**DODGE / CHRYSLER**  
**2005-08 MAGNUM SE**  
**2006-10 CHARGER SE**  
**2005-10 300**  
**V6-2.7L**

**TOOLS NEEDED:**

- Flat Blade Screwdriver
- Ratchet
- Extension
- 10mm Socket
- 13mm Socket
- 10mm Wrench
- 4mm Allen

**PARTS LIST:**

Description	Qty.	Part #
A Hose Clamp #44	2	08560
B Hose; 2.75"ID X 2", Silicone	1	08756
C Grommet	1	08064
D Intake Tube	1	087162
E Hose Clamp #48	1	08601
F Hose; 1/2"ID X 4.5"L	1	08485
G Bolt; 6mm F/H/A	1	08376
H Saddle Clamp; SS	1	078855
I Cup Washer	1	08180
J Washer; 1/4"ID X 5/8"OD, Flat	1	08275
K Nut; 6mm Nylock	1	07553
L Bracket; "Z"	1	010096
M Washer; 5/16"ID X 5/8"OD, Flat	1	08276
N Washer; 8mm Wave	1	08239
O Bolt; 8mm-1.25x16mm, Hexhead	1	07844
P Hose Clamp #56	2	08620
Q Hose; 3.5"ID X 2"L, Silicone	1	08630
R Bolt; 6mm B/H/A	2	07730
S Washer; Split Lock, 1/4"	2	08198
T Washer, Fender	2	08160
U Washer; 1"x.300"x.100" Rubber	2	21685
V Edge Trim 44"L	1	102486
W Heat Shield	1	074035
X Filter Adapter; #190	1	08806
Y Hose Clamp #104	1	08697
Z Air Filter	1	RF-1048

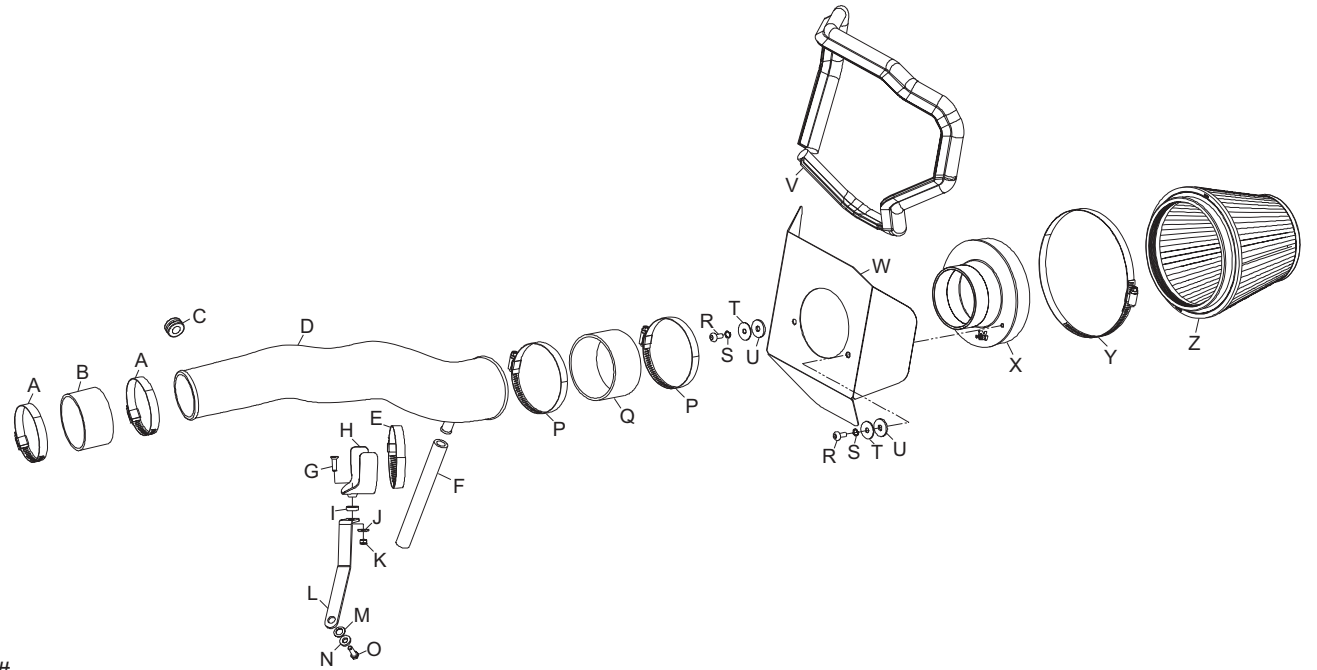

**NOTE: FAILURE TO FOLLOW INSTALLATION INSTRUCTIONS AND NOT USING THE PROVIDED HARDWARE MAY DAMAGE THE INTAKE TUBE, THROTTLE BODY AND ENGINE.**

**TO START:**

1. Turn off the ignition and disconnect the negative battery cable.

**NOTE: Disconnecting the negative battery cable erases pre-programmed electronic memories. Write down all memory settings before disconnecting the negative battery cable. Some radios will require an anti-theft code to be entered after the battery is reconnected. The anti-theft code is typically supplied with your owner's manual. In the event your vehicles' anti-theft code cannot be recovered, contact an authorized dealership to obtain your vehicles anti-theft code.**

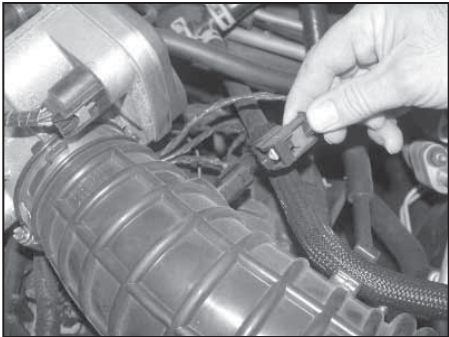

2. Unlock the red locking tab on the air temperature sensor electrical connection, then depress the locking lever and pull apart the air temperature sensor electrical connection.

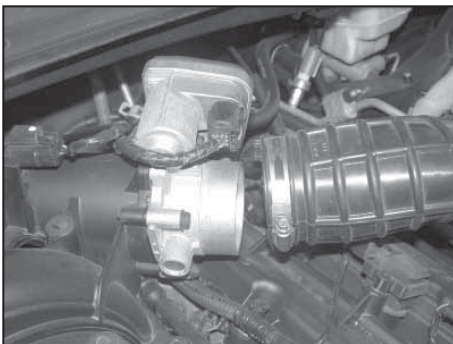

3. Loosen the hose clamp that secures the intake tube to the throttle body and pull the intake tube off the throttle body.



4. Disconnect the crankcase vent hose from the airbox as shown.

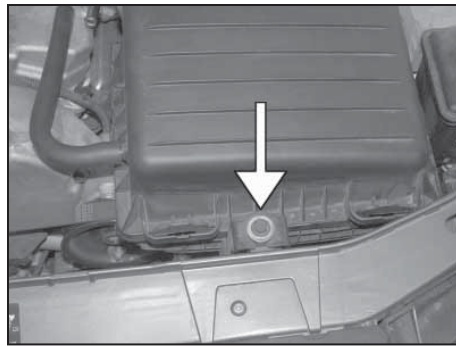

5. Loosen and remove the airbox mounting bolt as shown.

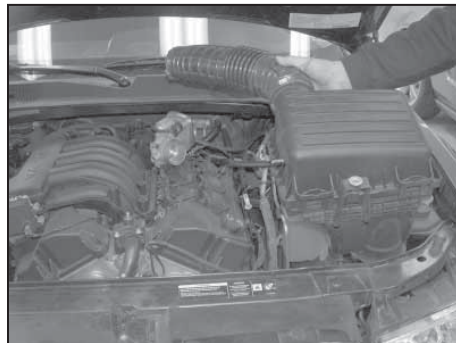

6. Lift the complete intake and air filter assembly to remove it from the vehicle.  
**NOTE: K&N Engineering, Inc., recommends that customers do not discard factory air intake.**



7. Assemble the tube-mounting bracket and saddle clamp as shown with the provided hardware.

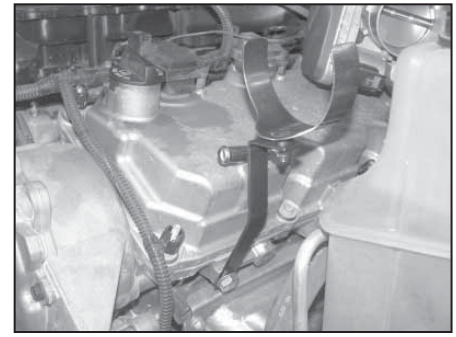

8. Using the provided hardware, install the tube-mounting bracket onto the engine at the threaded hole in the cylinder head as shown.

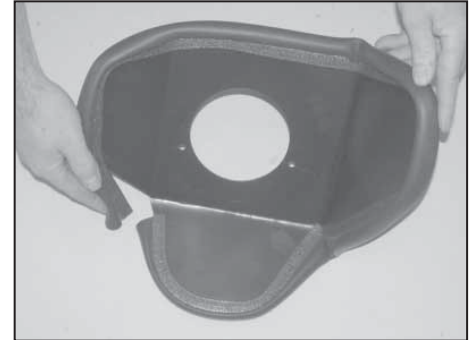

9. Install the provided edge trim onto the heat shield as shown.  
**NOTE: Some trimming of the edge trim may be necessary.**



10. Install the air filter adapter onto the heat shield with the provided hardware as shown.  
**NOTE: Be sure to use the rubber gaskets provided.**

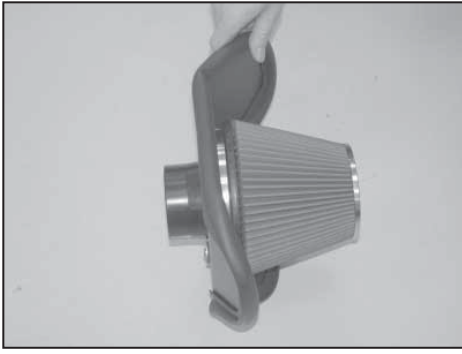

11. Install the K&N® air filter onto the filter adapter as shown.



12. Install the silicone hose (08630) onto the filter adapter and secure with the provided hose clamp as shown.

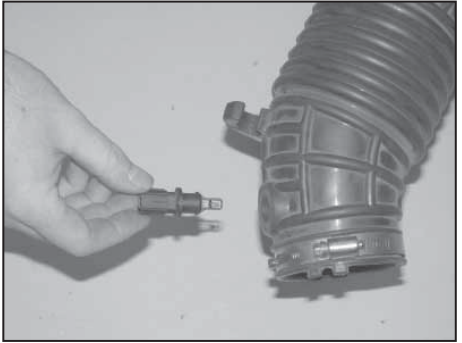

13. Remove the air temperature sensor from the factory intake tube.

**NOTE: The air temperature sensor is very fragile, be careful when pulling the sensor out of the intake tube.**



14. Install the grommet provide into the intake tube as shown.



15. Install the air temperature sensor into the grommet installed in step #14.



16. Install the air filter assembly onto the K&N® intake tube as shown.

**NOTE: Do not completely tighten the hose clamp at this time.**

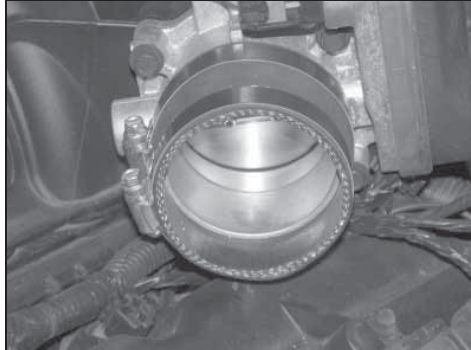

17. Install the silicone hose (08756) onto the throttle body and secure with the provided hose clamp as shown.

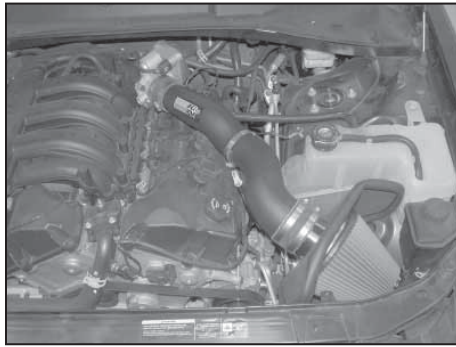

18. Install the K&N® intake assembly into the silicone hose at the throttle body and onto the saddle hose clamp as shown, then secure with the provided hose clamps. Adjust the air filter assembly for best clearance and tighten the hose clamp, which secures it to the K&N® intake tube.



19. Mark the crankcase vent tube approximately 1" back from the vent port on the K&N® intake tube as shown.

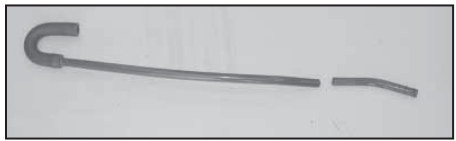

20. Remove crankcase vent tube from the engine and cut at the position marked in step #19 as shown.



21. Install the provided silicone hose onto the crank vent tube as shown.

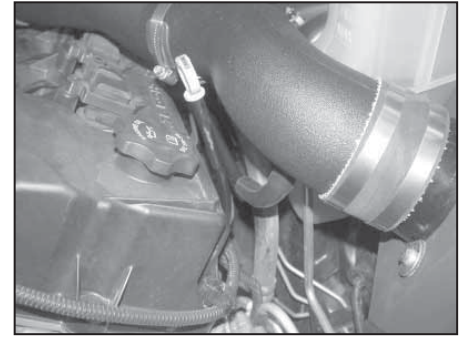

22. Reinstall the crankcase vent tube onto the valve cover and then connect to the K&N® intake tube as shown.

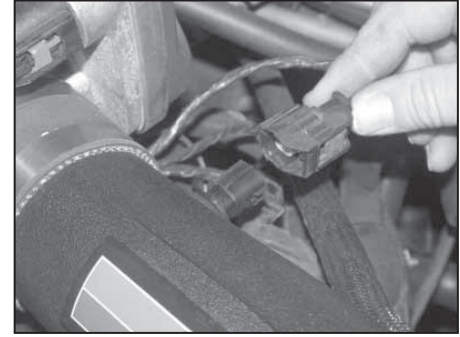

23. Reconnect the air temperature electrical connection as shown.

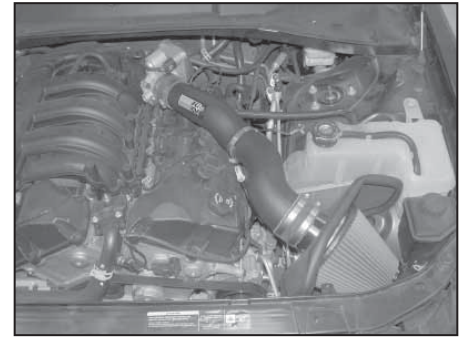

24. Reconnect the vehicle's negative battery cable. Double check to make sure everything is tight and properly positioned before starting the vehicle.

25. The C.A.R.B. exemption sticker, (attached), must be visible under the hood so that an emissions inspector can see it when the vehicle is required to be tested for emissions. California requires testing every two years, other states may vary.

26. It will be necessary for all K&N® high flow intake systems to be checked periodically for realignment, clearance and tightening of all connections. Failure to follow the above instructions or proper maintenance may void warranty.

#### ROAD TESTING:

1. Start the engine with the transmission in neutral or park. Listen for air leaks or odd noises. For air leaks secure hoses and connections. For odd noises, find cause and repair before proceeding. This kit will function identically to the factory system except for being louder and much more responsive.

2. Test drive the vehicle. Listen for odd noises or rattles and fix as necessary.

3. If road test is fine, you can now enjoy the added power and performance from your kit.

4. K&N Engineering, Inc., suggests checking the air filter element periodically for excessive dirt build-up. When the element becomes covered in dirt (or once a year), service it according to the instructions on the Recharger® service kit, part number 99-5050 or 99-5000.

**50-STATE STREET LEGAL**  
**K&N CARB EXEMPT K&N**

\* FREE K&N® decal To register your warranty, please see us online at [knfilters.com/register](http://knfilters.com/register). FREE K&N® decal \*

• 1455 CITRUS ST., P.O. BOX 1329, RIVERSIDE, CA., U.S.A. 92502 • TECH SERVICE 800-858-3333 • FAX 951-826-4001  
 • e-mail: [tech@knfilters.com](mailto:tech@knfilters.com) • WWW: <http://www.knfilters.com>