



INSTALLATION INSTRUCTIONS

57-1003
BMW
2001-05 M3
L6-3.2L

TOOLS NEEDED:

Ratchet
 Extension
 10mm Socket
 13mm Socket
 Flat Blade Screwdriver
 4mm Allen Wrench

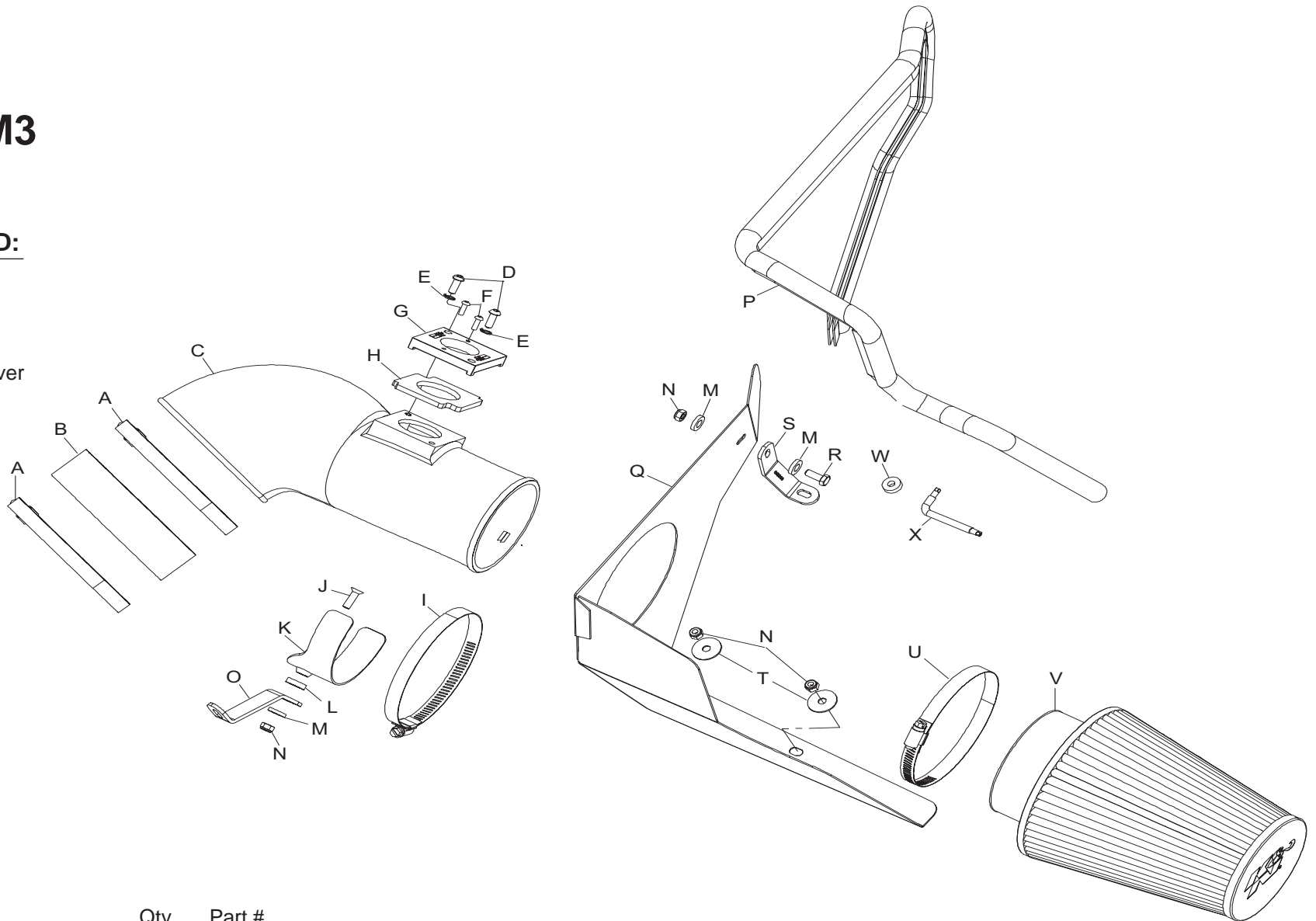

PARTS LIST:

Description	Qty.	Part #	Description	Qty.	Part #	Description	Qty.	Part #
A hose clamp #80	2	08685	I hose clamp #60	1	08628	Q heat shield	1	07499
B hose; 5.19" id x 1.5" l, black	1	08612	J bolt; 6mm-1.00 x 16mm, f/h/a	1	08376	R bolt; 6mm-1.00 x 16mm, hex	1	07703
C intake tube	1	087154	K saddle bracket	1	078855	S bracket sm "u"	1	010090
D bolt; 6mm-1.00 x 25mm, b/h/a	2	07729	L cup washer	1	08180	T washer; fender	2	08160
E washer; 1/4" split lock	2	08198	M washer; 1/4" id x 5/8" od	3	08275	U hose clamp #64	1	08648
F bolt; m4-.7 x 12mm, b/h/a	2	07726	N nut; 6mm nylock	4	07553	V air filter	1	RF-1032
G adapter #440	1	21517	O bracket	1	010091	W spacer; 1.0" od x .37" id x .23" thk,	1	08281
H gasket	1	09074	P edge trim 50"	1	102481	X wrench, T20	1	69801

NOTE: FAILURE TO FOLLOW INSTALLATION INSTRUCTIONS AND NOT USING THE PROVIDED HARDWARE MAY DAMAGE THE INTAKE TUBE, THROTTLE BODY AND ENGINE.

TO START:

1. Turn off the ignition and disconnect the negative battery cable.

NOTE: Disconnecting the negative battery cable erases pre-programmed electronic memories. Write down all memory settings before disconnecting the negative battery cable. Some radios will require an anti-theft code to be entered after the battery is reconnected. The anti-theft code is typically supplied with your owner's manual. In the event your vehicles' anti-theft code cannot be recovered, contact an authorized dealership to obtain your vehicles anti-theft code.



2. Remove the four 13mm nuts that secure the strut toner brace to vehicle, then remove brace from vehicle.



3. Squeeze the two locking tabs together, then remove the mass air electrical connection as shown.



4. Loosen the hose clamp at the intake plenum and release the two clips that secure the air box lid to vehicle, then remove the upper air box and intake tube as shown.



5. Remove cover to the head light module to gain access to the air box bolts and module nut, then remove the bolts and nut.



6. Lift the head light module, placing on core support to give access of lower air box for removal.



7. Remove lower air box assembly as shown.
NOTE: K&N Engineering, Inc., recommends that customers do not discard factory air intake.



8. Lift up on lower air box mount then remove from vehicle.



9. Remove the nut that secures the dip stick to the intake plenum.



10. Remove the intake o-ring from plenum as shown.



11. Install the edge trim onto the heat shield as shown.
NOTE: Trim if necessary.



12. Install the heat shield into the vehicle. Make sure the lower air box mounting stud protrude through heat shield mounting holes.



13. Secure heat shield to vehicle with the provided hardware. Then secure bracket (010090) to heat shield and inner fender.
NOTE: Use bolt that was removed in step 5 to secure bracket to inner fender.



14. Re-install head light module with the original hardware that was removed in step 5.
NOTE: Install provided spacer under front mount as shown. Then re-install module cover.



15. Install silicone hose (08612) onto intake plenum as shown using the provided hose clamps.



16. Remove the two screws that secure the mass air sensor to the air box with the wrench provided, then remove the mass air sensor.



17. Install the provided gasket onto the mass air adapter as shown. Stick side down.

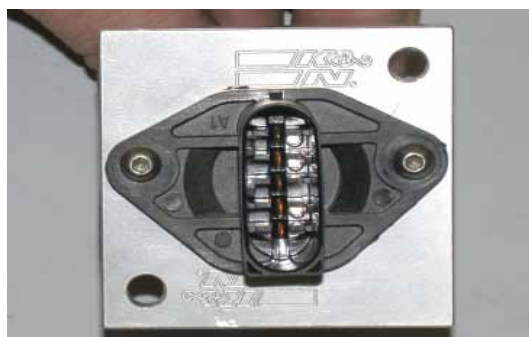

18. Install the mass into the mass air adapter as shown and secure with the provided hardware.

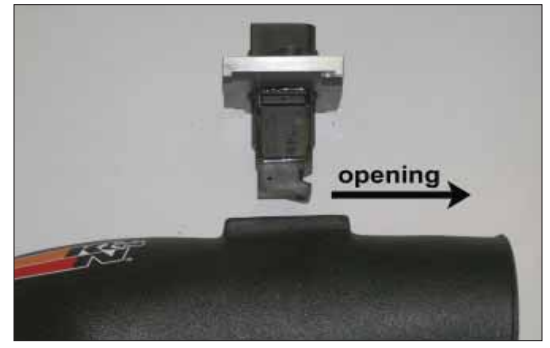

19. Install the mass air sensor assembly into the K&N intake tube.
NOTE: Make sure the open end of the mass air sensor is towards the filter end of the tube.



20. Secure the mass air sensor assembly onto the new intake tube with the provided hardware as shown.



21. Install the K&N intake tube onto the plenum with the provided hose clamp.
NOTE: Do not tighten hose clamps completely.



22. Assemble the saddle clamp to the tube bracket (010091) with the provided hardware as shown.



23. Install the saddle bracket assembly onto the intake plenum with the nut that was removed in step 9, then attach the intake tube to saddle bracket with the provided hose clamp.



24. Install the air filter onto the new intake tube and secure with the provided hose clamp.



25. Reconnect the mass air sensor electrical connection as shown.



26. Re-install the strut tower brace that was removed in step 2.



27. Reconnect the vehicle's negative battery cable. Double check to make sure everything is tight and properly positioned before starting the vehicle.

28. The C.A.R.B. exemption sticker, (attached), must be visible under the hood so that an emissions inspector can see it when the vehicle is required to be tested for emissions. California requires testing every two years, other states may vary.

29. It will be necessary for all K&N® high flow intake systems to be checked periodically for realignment, clearance and tightening of all connections. Failure to follow the above instructions or proper maintenance may void warranty.

ROAD TESTING:

1. Start the engine with the transmission in neutral or park. Listen for air leaks or odd noises. For air leaks secure hoses and connections. For odd noises, find cause and repair before proceeding. This kit will function identically to the factory system except for being louder and much more responsive.

2. Test drive the vehicle. Listen for odd noises or rattles and fix as necessary.

3. If road test is fine, you can now enjoy the added power and performance from your kit.

4. K&N Engineering, Inc., suggests checking the air filter element periodically for excessive dirt build-up. When the element becomes covered in dirt (or once a year), service it according to the instructions on the Recharger® service kit, part number 99-5050 or 99-5000.

50-STATE STREET LEGAL
K&N CARB EXEMPT K&N

* FREE K&N® decal To register your warranty, please see us online at knfilters.com/register. FREE K&N® decal *

• 1455 CITRUS ST., P.O. BOX 1329, RIVERSIDE, CA., U.S.A. 92502 • TECH SERVICE 800-858-3333 • FAX 951-826-4001
 • e-mail: tech@knfilters.com • WWW: <http://www.knfilters.com>

18479d
 9/15/10