

PLEASE READ THE INSTRUCTIONS CAREFULLY BEFORE FITTING THE KIT**If you have a problem, however small, call our Technical Department.**

Tel:- 01925 636950. Fax:- 01925 418948. Monday to Friday 9am - 5pm.

- 1 To make the operation easier, raise the front of the car. **Taking all the necessary safety precautions.**
- 2 Remove the air box lid and push off the rubber intake hose. **Don't remove the coil spring clip from the intake hose.**
- 3 Pull out the resonator box and remove the air box assembly. **Drawing A.**
- 4 Attach the new bracket to the metal tube with the stud at the front . **Drawings B & C.** Attach the bracket to the rear air box mounting with the M6 x 16 screw and spring washer.
- 5 Push the intake hose over the metal pipe, without removing the coil spring clip. **Drawing C.**
- 6 Fit the filter up to the bracket keeping the filter square to the pipe. Adjust the filter until the K&N logo is straight before tightening in place. Tighten the clip until the filter just rotates, then give one full turn (360 degrees). No more. **Don't overtighten the clip.**
- 7 **Cold Air System**
Remove the plastic screen next to the radiator. Cut out the section indicated. **Drawing D.**
- 8 Refit the plastic screen, but leave out the plastic screw in the front panel behind the bonnet catch.
- 9 Remove one of the plastic sleeves from the flexi cold air hose and carefully expand the hose to approx. 53 cm / 21". Screw the flexi cold air hose into the tapered end of the rubber hose. Feed the new hose assembly hose through the new hole in the plastic screen and under the P.A.S pipes to the lower front grille. **Drawing E.**
- 10 Pierce a small hole in the end of the rubber cold air hose and secure to the grille with a small tie. **Drawings E & F.**
- 11 Secure the top section of rubber hose with a long plastic tie attached through the hole in the front panel. **Drawings C & E.**
- 12 Attach the flexi hose to the fan bracket using a long tie. **Drawing C.**
- 13 **Tuning.**
CAT. Cars. No adjustments are required.
An increase in fuel may be required if further engine modifications are carried out.
- 14 **Filter Maintenance.**
Under normal conditions clean and reoil the filter at approx. 40,000 miles/65,000 Km.
Use only K&N Cleaner and oil and follow the instructions carefully.

K&N Filters are pre-oiled ready to fit.**The advantage's of K&N's cold air intake system**

Cooler air being denser, will show positive improvements in power over filter systems that draw hot air from the engine bay.

This Kit Should Contain

- 1 x Clamp on filter
- 1 x Metal tube
- 1 x Rubber Cold Air Hose
- 1 x Cold Air Hose Assembly
- 1 x Instruction Pack :-
 - 1 x K&N Window Sticker
 - 1 x Filter Maintenance Sheet
 - 1 x Million Mile Warranty
 - 1 x Leaflet
- 1 x Fixing Kit containing:-
 - 1 x M6 x 16 Hex head screw
 - 1 x M6 nut
 - 2 x 6mm spring washers
 - 2 x Cable ties (35cm long)
 - 1 x Cable tie (19cm long)
 - 1 x Hose Clip #48
 - 1 x Metal bracket
 - 1 x Instruction Sheet

**IMPORTANT INSTRUCTIONS
FOR ROUND ENTRY
CLAMP ON AIR FILTERS**

Gently tighten the hose clip to the point where the filter will just rotate on the pipe or intake flange. Reposition the K&N logo straight, then **give the clip two turns i.e. 360 , no more.**

FITTING YOUR OWN 57i KIT

If not, **it is essential** that the person fitting the kit (e.g. mechanic) **carefully follows these particular instructions** even if he has fitted K&N kits before. This will save you both time and money. Kits incorrectly fitted may show a loss in performance e.g. the positioning of the essential cold air hose, (flexi expandable and rubber hoses are used).

A final check under the bonnet, by yourself, with the instructions, would seem sensible.

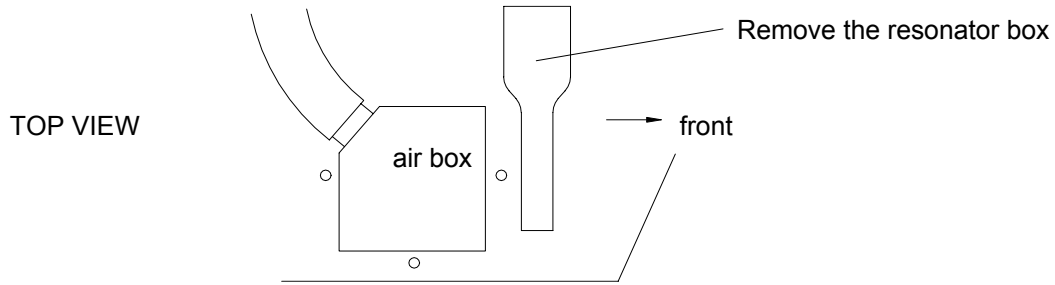

Drawing B

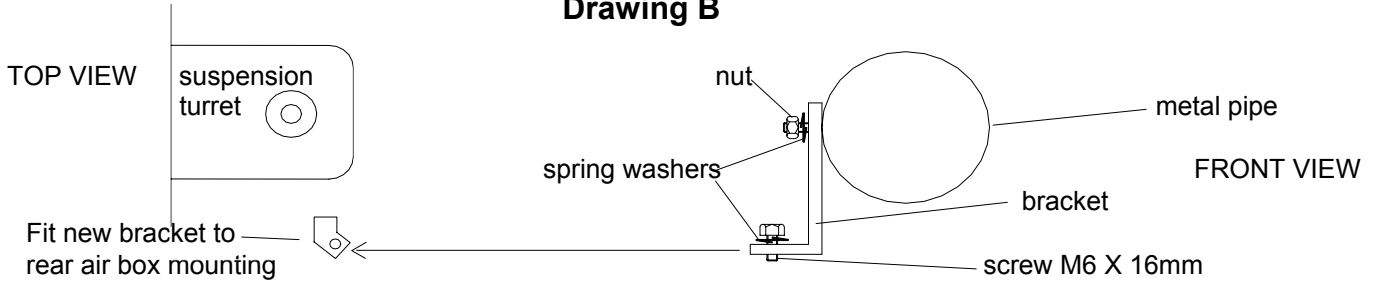

Drawing C

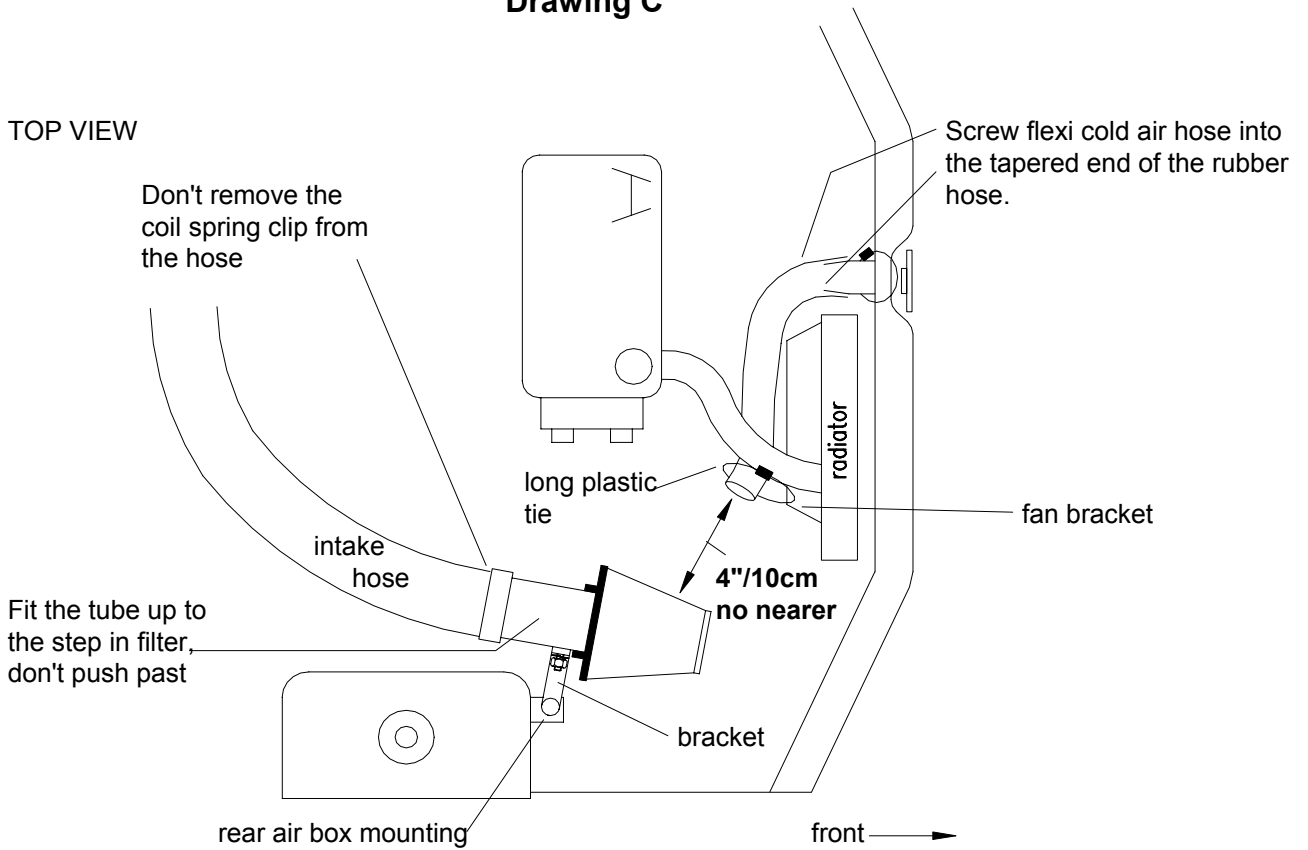

Drawing D

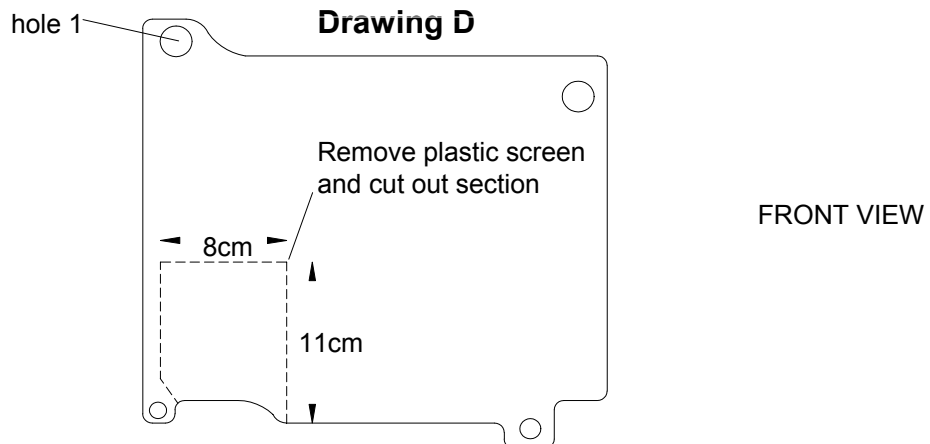

Drawing E

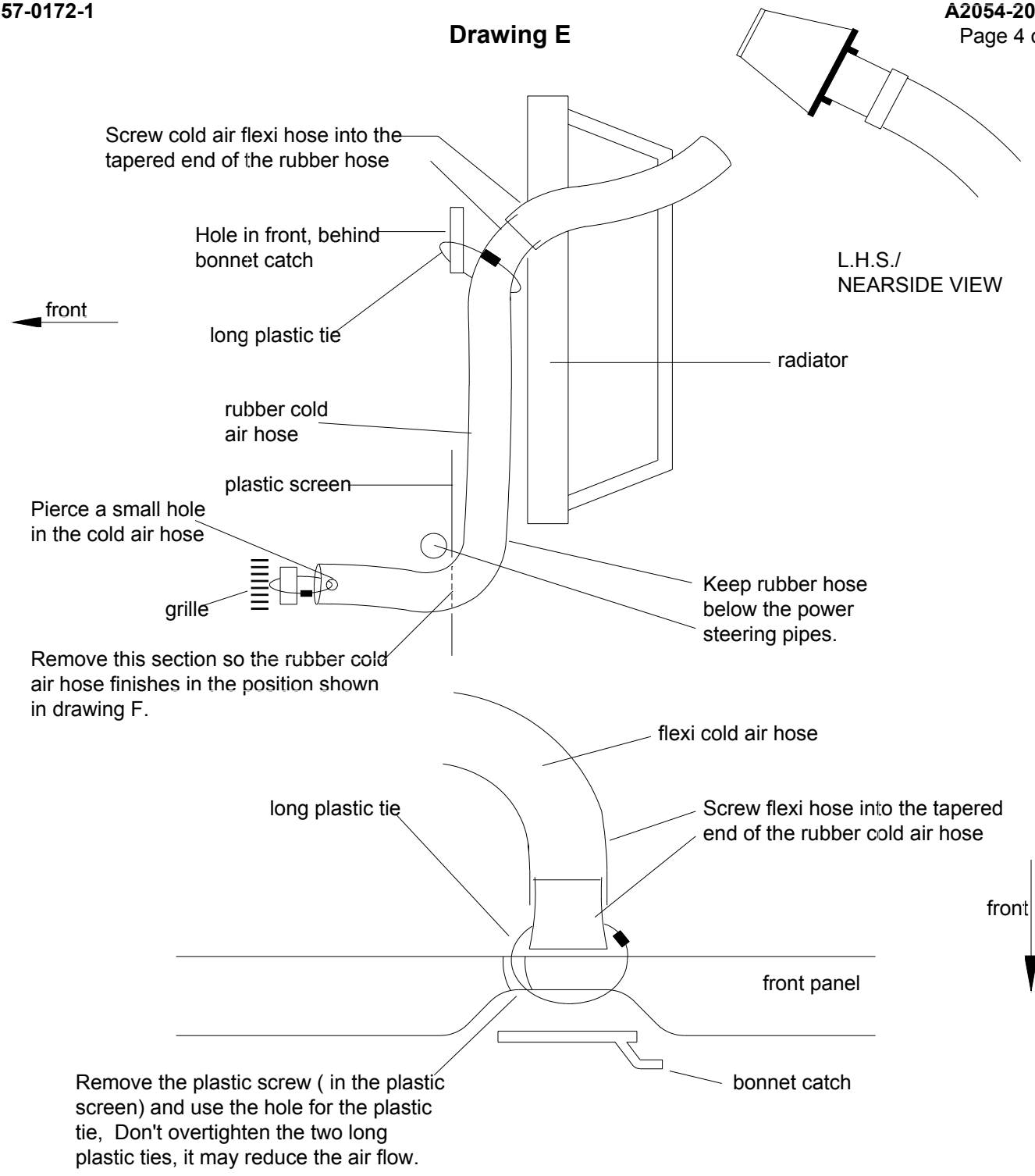

Drawing F

