

PLEASE READ THESE INSTRUCTIONS CAREFULLY BEFORE FITTING THIS KIT

If you have a problem, however small, call our Technical Department

Tel:- 01925 636950 Fax:- 01925 418948 Monday to Friday 9am - 5pm

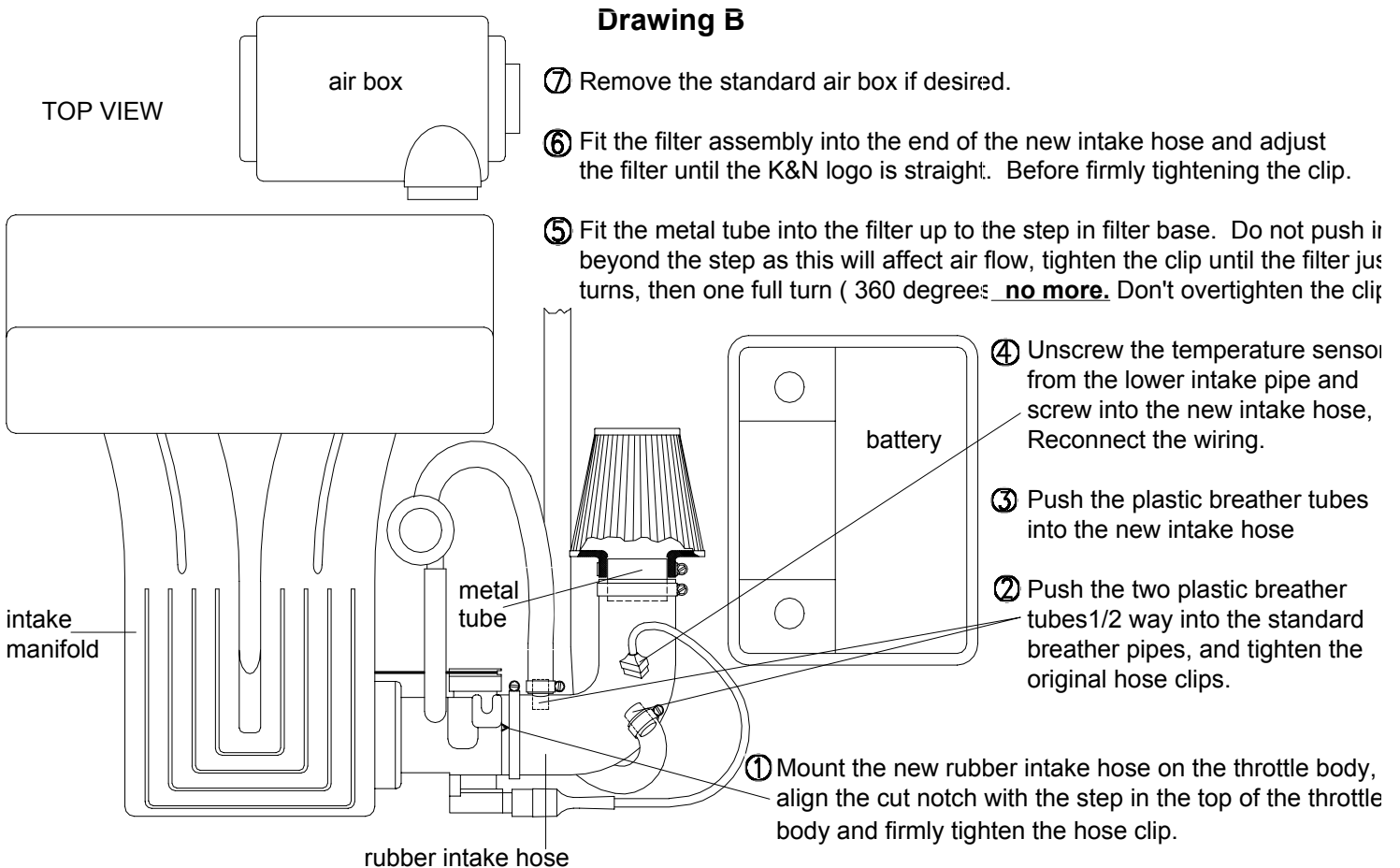
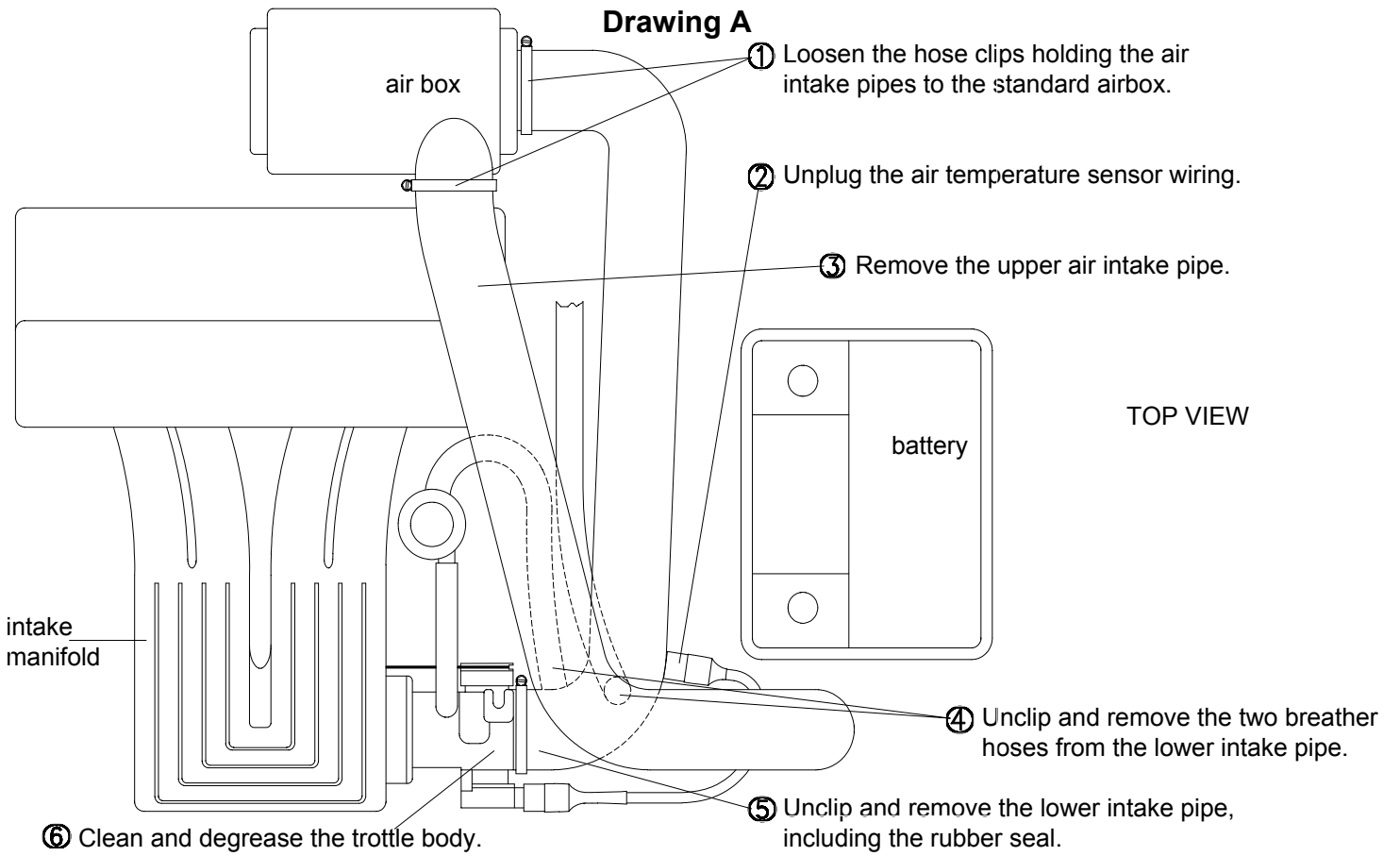

① Carefully expand the flexi cold air hose to 97cm/38". Feed the hose down between the engine and radiator to below the front spoiler.

② Position the top of the flexi cold air hose to finish approx 10cm/4" from the filter (no nearer).
Pierce / drill a small hole (approx 3mm) in the end of the flexi cold air hose and tie the hose to the plastic battery carrier using the medium plastic tie supplied.

③ Cut out in the new intake hose aligned with the step in the throttle body.

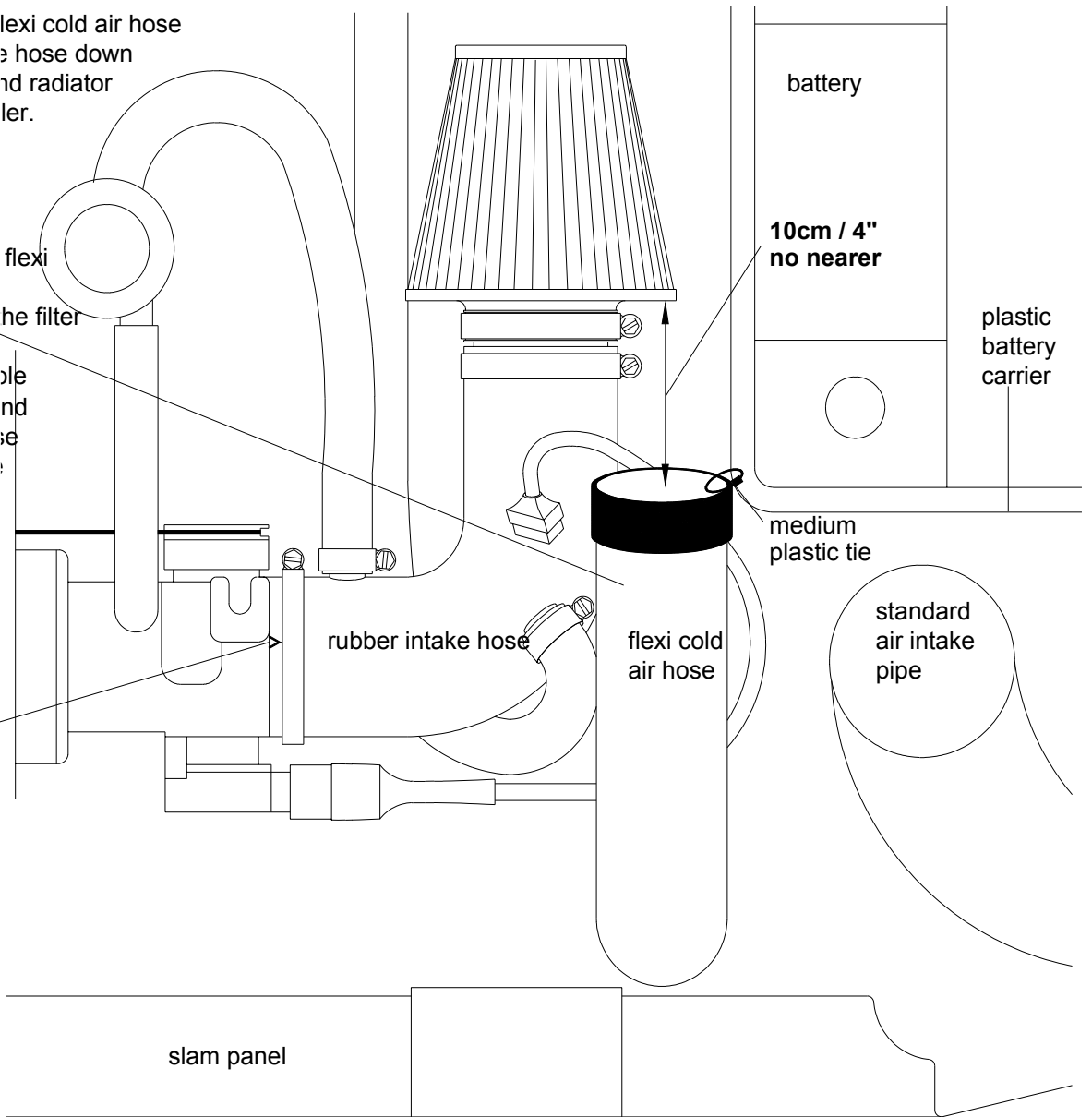

TOP VIEW

Drawing D

FRONT VIEW

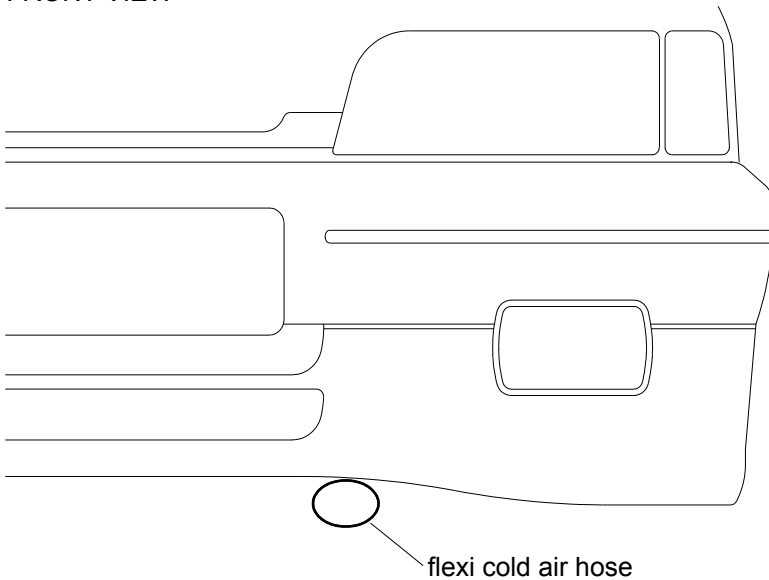

① Feed the cold air hose to the leading edge of the front bumper. Ovalise the end of the hose

② Pierce / drill a small hole (approx. 3mm) in the end of the hose and tie to the rear of the tow hook using the long plastic tie supplied.

Tuning.**CAT. Cars** No adjustments required

An increase in fuel mixture may be required if further modifications are carried out.

Filter Maintenance.

Under normal conditions clean and reoil the filter at approx. 40,000 miles / 65,000km.

Use only K&N cleaner and oil and follow the instructions carefully.**K&N filters are pre-oiled ready to fit****The advantage of K&N's cold air intake system.**

Cooler air being denser, will show positive improvements in power over filter systems that draw hot air from the engine bay.

This Kit Should Contain:

- 1 x Clamp On Filter
- 1 x Cold Air Hose Assembly
- 1 x Rubber Intake Hose
- 1 x Instruction Sheet
- 1 x Instruction Pack:-
- 1 x Filter Maintenance Sheet
 - 1 x K&N window sticker
 - 1 x Million Mile sticker
 - 1 x Million Mile Warranty
 - 1 x Leaflet
- 1 x Fixing Kit containing:-
 - 2 x Plastic Breather Tubes
 - 2 x #48 Hose clips
 - 1 x #40 Hose clip
 - 1 x Long Cable Tie
 - 1 x Medium Cable Tie
 - 1 x Metal Intake Tube

FITTING YOUR OWN 57i KIT

If not **it is essential** that the person fitting the kit (e.g. mechanic) **carefully follows these particular instructions** even if he has fitted K&N kits before. This will save you both time and money. kits incorrectly fitted may show a loss in performance e.g. the positioning of the essential cold air hose, (flexi expandable and rubber hoses are used).

A final check under the bonnet, by yourself with the instructions, would seem sensible