

PLEASE READ THE INSTRUCTIONS CAREFULLY BEFORE FITTING THIS KIT.

If you have a problem, however small, call our Technical Department.

Tel:- 01925 636950. Fax:- 01925 243111. Mon - Thurs 8.30 - 5pm. .

- 1 Remove the complete air box assembly.
- 2 Fit the filter to the throttle body, adjust the filter until the K&N logo is straight before tightening the clip. Tighten the clip until the filter just rotates, then give one full turn (360 degrees). No more. **But don't overtighten the clip.**
- 3 Fitting the cold air system. **Drawing A.**
Carefully expand the hose to approx 80cm / 32".
- 4 Feed the hose past the battery and down under the slam panel to finish up against the grille, **Drawing B.** Attach with plastic tie to the hole in the slam panel.
- 5 Using a plastic tie attach the other end of the air hose to the radiator hose, **Drawing A.** Finish the hose 10cm / 4" away from the filter, **no nearer.**
- 6 **Tuning.**
CAT. Cars. No adjustments are required
An increase in fuel may be required if further engine modifications are to be carried out.

NON. CAT. Cars.

We suggest that a simple **CO** test be carried out, as some cars may be set weaker than the standard setting. The **CO** figure should not be set at more than **0.5%** above the recommended figure.

7 Filter Maintenance.

Under normal conditions clean and reoil the filter at approximately 40,000 miles / 65,000 km. **Use only K&N cleaner** and oil and follow the instructions carefully.

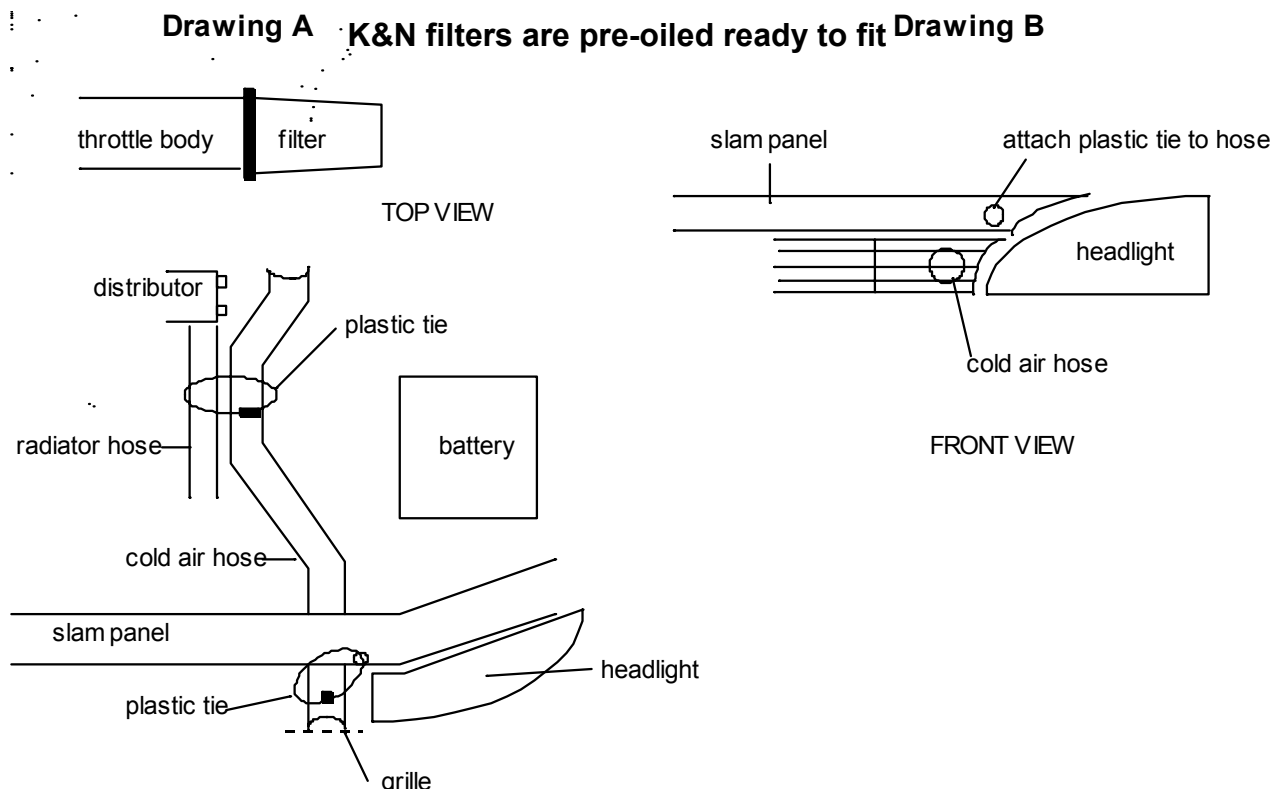

The advantage's of K&N's cold air intake system
Cooler air being denser will show positive improvements over
systems that draw hot air from the engine bay.

This kit should contain:-

- 1 x Air Filter.
- 1 x Hose Clip #44
- 1 x Cold air hose assembly.
- 2 x Long Cable Ties.
- 1 x Instruction sheet.
- 1 x Instruction pack:-
 - 1 x Filter maintenance sheet.
 - 1 x K&N window sticker.
 - 1 x Million mile warranty card.
 - 1 x Leaflet.

**IMPORTANT INSTRUCTIONS
FOR ROUND ENTRY
CLAMP ON AIR FILTERS**

Gently tighten the hose clip to the point where the filter will just rotate on the pipe or intake flange. Reposition the K&N logo straight, then **give the clip two turns i.e. 360 , no more.**

FITTING YOUR OWN 57i KIT

If not, **it is essential** that the person fitting the kit (e.g. mechanic) **carefully follows these particular instructions** even if he has fitted K&N kits before. This will save you both time and money. Kits incorrectly fitted may show a loss in performance e.g. the positioning of the essential cold air hose, (flexi expandable and rubber hoses are used).

A final check under the bonnet, by yourself, with the instructions, would seem sensible.