

PLEASE READ THE INSTRUCTIONS BEFORE FITTING THE KIT.
If you have a problem, however small, call our Technical Department.
Tel:- 01925 636950. Fax:- 01925 418948. Monday to Friday 9am - 5pm.

- 1 Follow **Drawing A** instructions.
- 2 Remove hose, **Drawing G** instructions.
- 3 Follow **Drawing B** instructions.
- 4 Follow **Drawing C** instructions.
- 5 Fit the new rubber intake hose, **Drawing D**. Use the yellow mark as a guideline, **Drawing E**. Push hose fully onto the intake flange and position hose clip flush to the end and **firmly tighten**.
- 6 **Drawing D**. Fit half of the metal tube into the intake hose. Tighten hose clip until the hose can just rotate then give the clip one full turn. Fit the other half of the tube into the filter and tighten the hose clip until the filter just rotates. Rotate the filter until the K&N logo is straight, then tighten the clip one more turn (360 degree's) no more. **Do not overtighten filter clip**.
- 7 With the filter fitted and the **K&N logo straight** there should be clearance from the battery and top hose. Small adjustments can be made by rotating the rubber intake hose, **leave the larger space near the battery, Drawing D. Fitting the two new hoses**
 - 8.1 See **Drawing F**, position for new hoses. Remove the original cold start hose and replace with the new hose including plastic tube. Fit into **lower** hole in filter.
 - 8.2 Remove the short hose attached to the black plastic unit. Twist the unit to finish as **Drawing G.2**.
 - 8.3 Fit one end of the new breather hose to the black unit. Fit the other end, including plastic tube, over the new cold start hose and into the filter. No hose clips are required.
- 9 Remove top grille section, **Drawing H**.

Cold air intake system

 - 10.1 Cut out the blanked off sections of the lower grille, for increased cold air, **Drawing J.2**.
 - 10.2 Drill the holes in the plastic duct as **Drawing K**, to line up with the holes in rubber air duct. Use the plastic tie to attach the rubber duct to the plastic duct. Lowering the rubber duct will make it easier to locate the plastic tie in the holes. Position the clip at the back.
 - 10.3 Refit the plastic duct to the front panel with the screw. Fit the angled rubber deflector to direct cold air to the filter area. **Do not extend the deflector**.
- 11 **Tuning.**

CAT. Cars, no adjustments are required if the filter kit is the only modification. Fitting a chip suitable for this car will increase the overall performance.
- 12 **Filter maintenance.**

Under normal conditions, clean and reoil the filter at approx. 40,000 miles / 65,000 km. **Use only K&N cleaner** and oil and follow the instructions carefully.

K&N filters are pre oiled ready to fit

The advantages of K&N's cold air intake system

Cooler air, being denser, will show positive improvements in power over filter systems that draw hot air from the engine bay.

This Kit Should Contain :-

- 1 x Clamp-On Filter.
- 1 x Metal Tube.
- 1 x Rubber Intake Hose.
- 2 x Rubber Breather Hoses.
- 1 x Rubber Cold Air Duct.
- 1 x Oval Rubber Air Deflector
- 1 x Instruction Sheet.
- 1 x Instruction Pack:-
 - 1 x Filter Maintenance Sheet.
 - 1 x K&N Window Sticker.
 - 1 x Million Mile Warranty Card.
 - 1 x Leaflet.
- 1 x Fixing Kit Containing :-
 - 1 x #40 Hose Clip.
 - 1 x #44 Hose Clips.
 - 1 x Plastic Cable Tie (35cm Long).
 - 2 x Plastic Tubes

FITTING YOUR OWN 57i KIT

If no **it is essential** that the person fitting the kit (e.g mechanic) **carefully follows these particular instructions** even if he has fitted K&N kits before. This will save you both time and money. Kits incorrectly fitted may show a loss in performance e.g the positioning of the essential cold air hose, (flexi expandable and rubber hoses are used).

A final check under the bonnet by yourself with the instructions, would seem sensible.

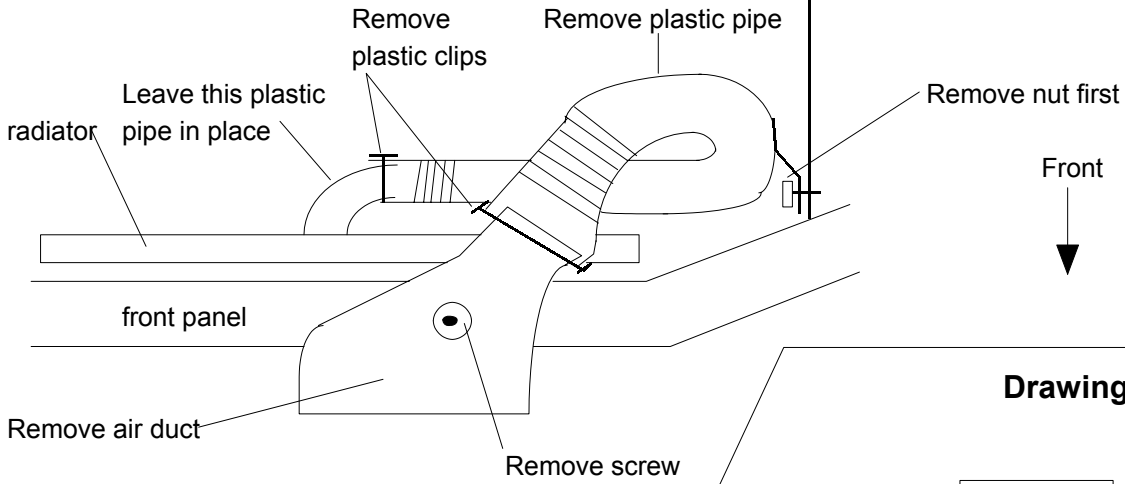

Drawing C

TOP VIEW

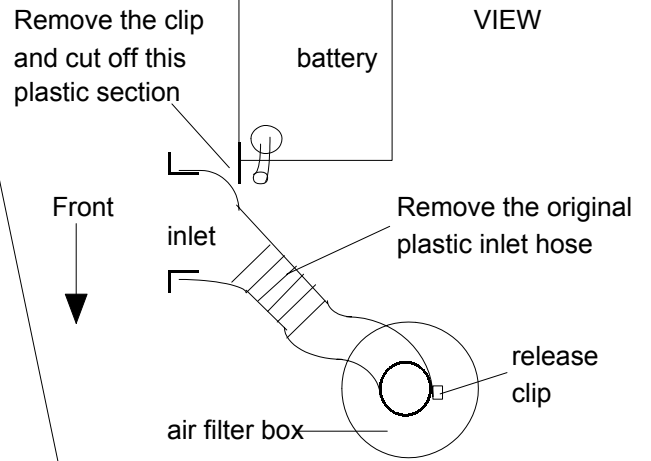

Drawing B

OFFSIDE VIEW

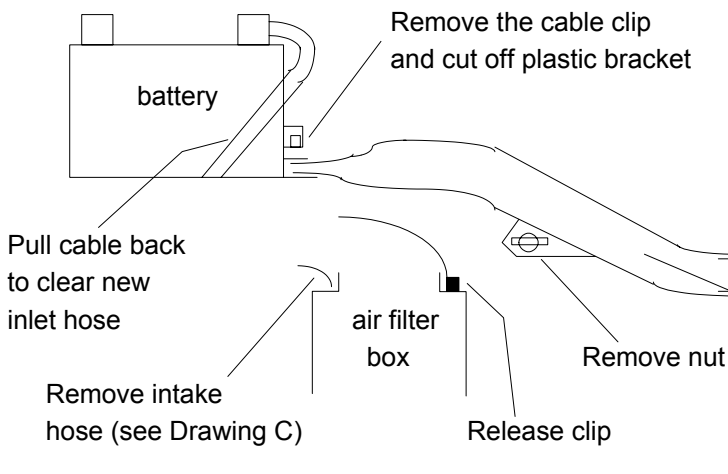

This long plastic duct must be removed to give access to the hose clip on the top of air filter box

Drawing E

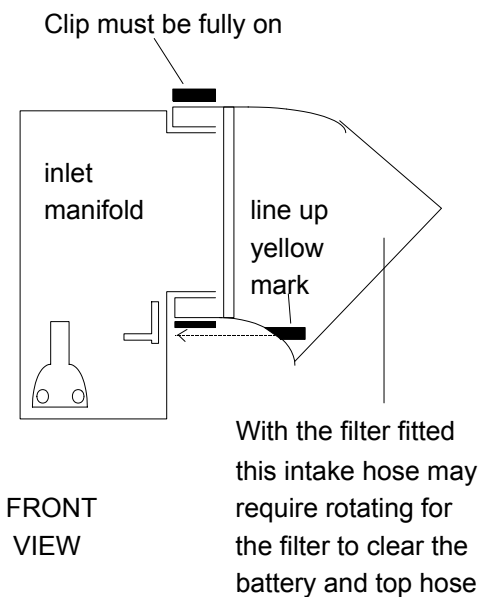

Drawing F

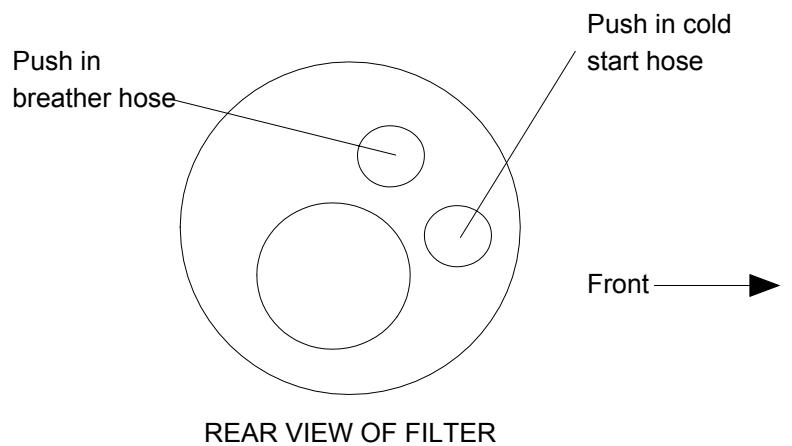

Drawing H

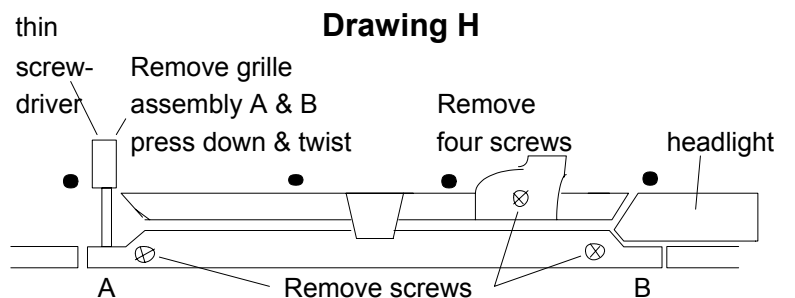

Drawing D

Section 7

If required, rotate the new rubber intake hose for the filter to the clear battery

TOP VIEW

See instruction sheet for correct clip fitting on the filter

Front

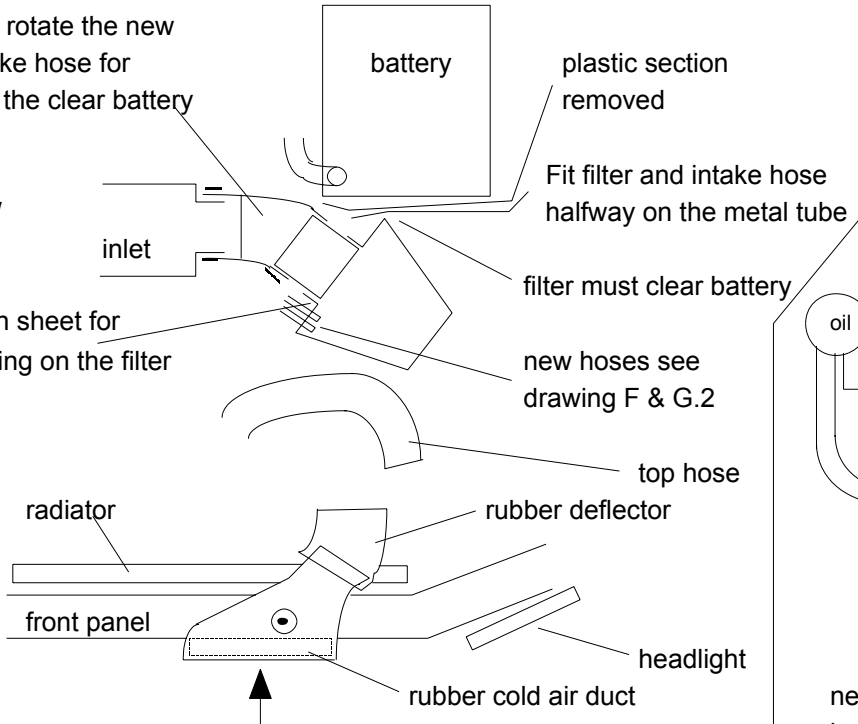

Drawing G.1

Remove this hose to provide more space while fitting the kit. replace hose later.

Remove original short hose. (degrease neck) twist black unit (no need to remove clip). to finish in a flat position with the new breather hose **above** the new cold start hose

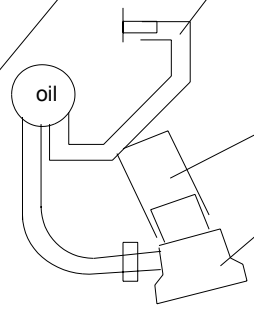

Drawing J.1

FRONT VIEW

rubber cold air duct

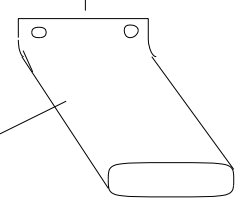

Drawing G.2

Remove cold start hose and fit new hose

Fit plastic tubes in hoses first

black unit

original breather hose

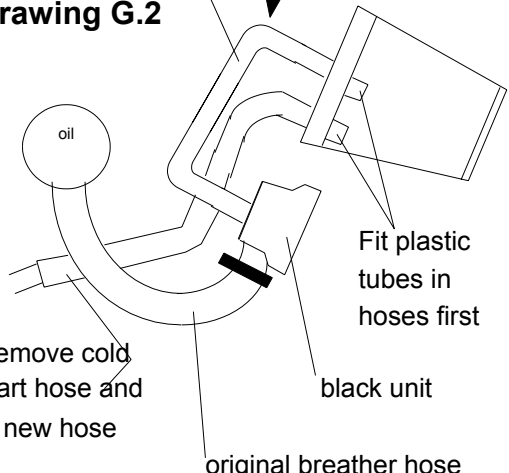

Drawing J.2

Cut out the sections to increase cold air

bumper

cold air duct

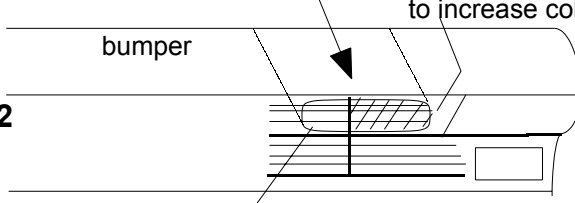

Drawing K

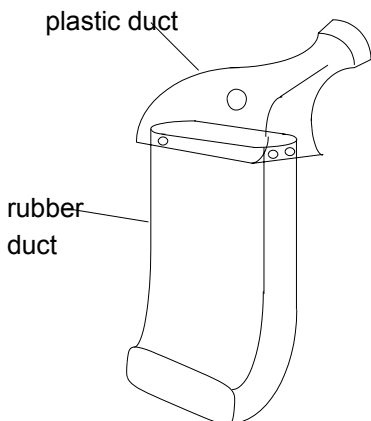

Use long plastic tie to hold duct together, finish clip at the back of plastic duct. **section 10.2**

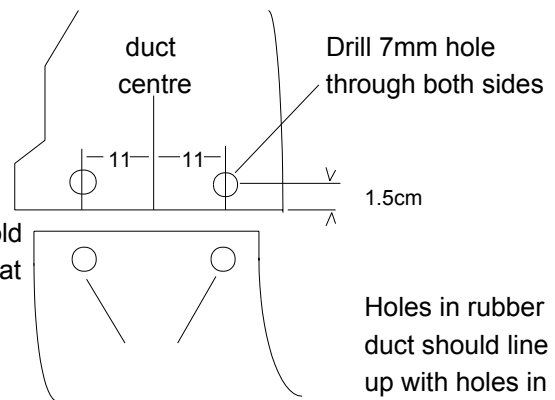

Holes in rubber duct should line up with holes in plastic duct

FRONT VIEW